

DW-6000

PROGRAMMABLE
DIGITAL WAVEFORM
SYNTHESIZER
OWNER'S MANUAL



KORG[®]

KORG[®] DW-6000

PROGRAMMABLE DIGITAL WAVEFORM SYNTHESIZER



Thank you and congratulations on your choice of the Korg DW-6000. To obtain optimum performance from this advanced digital synthesizer, please read this manual carefully before using.

2 Has two Digital Oscillators per voice. Each oscillator has eight digitally encoded waveforms stored in two 256 kilobit ROM chips. Unlike the simple sawtooth and pulse waveforms of other synths, the DW-6000's waveforms are digitally encoded samples of actual acoustic instruments, to enable more convincing, realistic sound synthesis.

1 A new kind of 6-voice programmable polyphonic synthesizer featuring an advanced Digital Waveform Generator System (DWGS) for sonic richness, plus powerful VCF, VCA and EG modules, for excellent control and flexibility.

3 The DW-6000 features analog processing via VCF and VCA modules, for ease of operation. You enjoy the uniqueness of digital sound plus the fat sounds and ease of use of analog control.

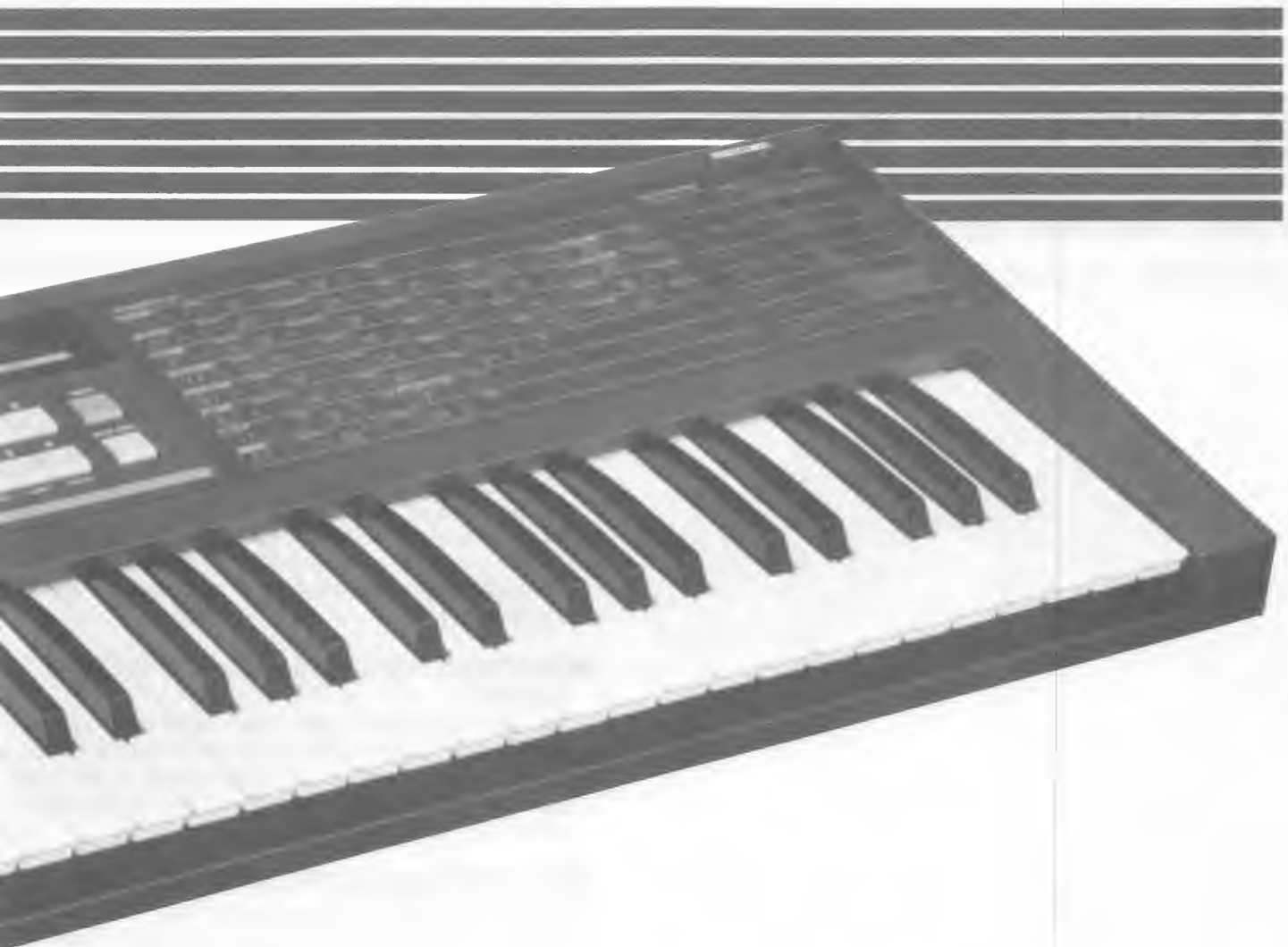

FEATURES OF THE KORG DW-6000

4 More flexible dynamic control, with two 6-parameter "ADBSSR" digital envelope generators per voice, one each for the VCA and VCF, respectively.

5 64 different programs can be stored and accessed by fingertip control. A footswitch can be used to advance the program number, for on-stage convenience. 14 Rapid second tape interface permits unlimited storage and rapid reloading of program libraries.

6 Polyphonic Portamento, controllable by foot switch. Its setting can be stored for each programmed sound.

7 Programmable Key assign mode lets you select unison and polyphonic modes so you can use the DW-6000 as a versatile monophonic soloing or polyphonic synthesizer.

8 MIDI equipped for full interfacing with other MIDI equipped devices, including synthesizers, sequencers, remote keyboards, expander modules, rhythm machines, and personal computers.

9 Noise generator included for special effects.

10 Built-in stereo chorus for spacious stereo reproduction.

IMPORTANT SAFETY PRECAUTIONS

Please read and observe the following precautions to assure reliability and safety.

■ LOCATION

To avoid malfunction do not use this unit in the following locations for long periods of time:

- In direct sunlight.
- Exposed to extremes of temperature or humidity.
- In sandy or dusty places.

■ POWER SUPPLY

- Use only with rated AC voltage. If you will be using this unit in a country having a different voltage, be sure to obtain the proper transformer to convert to rated voltage.
- To help prevent noise and degraded sound quality, avoid using the same outlet as other equipment or branching off extension cords shared by other equipment.

■ INPUT/OUTPUT JACKS AND CONNECTION CORDS

Be sure to use standard "guitar" cables with phone plugs, such as the cable supplied with this instrument, for input and output connections to the rear panel of the DW-6000. Never insert any other kind of plug into these jacks.

■ PREVENTING ELECTRICAL INTERFERENCE

As a microprocessor based device, the DW-6000 is extremely flexible in operation, yet may possibly perform erratically if exposed to electrical interference from other electrical devices and fluorescent lamps. Avoid operating the DW-6000 near possible sources of interference. If something seems to be wrong, try turning off the power, waiting about ten seconds, the turning it back on. This resets the computer circuits to their initial state so performance should return to normal.

■ HANDLE GENTLY

Knobs and switches are designed to provide positive operation with a light touch. Excessive force may cause damage.

■ MAINTENANCE

Wipe the exterior with a soft, dry cloth. Never use paint thinner, benzene or other solvents.

■ KEEP THIS MANUAL

Store this manual in a safe place for future reference.

■ MEMORY BACKUP

- To protect your programmed memory contents, the DW-6000 utilizes a built-in rechargeable backup battery power supply. Battery life is rated at five years or more, so replacement is recommended after five years. Contact your Korg dealer or authorized service center at that time.
- For maximum security, save your sound programs on tape, using the built-in tape interface system. Then if memory contents are accidentally erased or altered, you can simply load the data back into DW-6000 internal memory in seconds!

CONTENTS

● FRONT PANEL LAYOUT	6
● REAR PANEL LAYOUT	8
● DW-6000 OVERVIEW	9
1 BASIC SETUP	10
2 SELECTING PROGRAMS	11
■ Features & Functions	11
■ About Program Numbers	11
■ How to Select a Program Number	12
3 CREATING SOUNDS	13
How to make new sounds	
■ Features & Control Functions	13
■ About the DW-6000's "Digital Access Control System"	13
■ The DW-6000 Approach to Sound Synthesis	14
■ How to Make New Sounds	14
■ Parameters and Values	15
● OSC1	15
● OSC2	16
● NOISE	16
● VCF	17
● CHORUS	18
● VCF EG, VCA EG	19
● MG	20
● BEND	21
● PORTAMENTO	21
● MIDI	22
4 WRITING PROGRAMS TO MEMORY	23
■ Features & Functions	23
■ Which Sections' Settings Can Be Stored in Memory?	23
■ Program Write Procedure	24
■ Repositioning Sounds in Memory	24
5 PERFORMANCE FEATURES	25
6 TAPE INTERFACE	28
■ Saving Program Data on Tape	29
■ A Word About Data Tones	29
■ VERIFY Procedure	30
■ LOAD Procedure	31
7 MIDI	33
■ How MIDI Works	33
■ DW-6000 MIDI Features	36
● SPECIFICATIONS/OPTIONS	40
● MIDI IMPLEMENTATION	42
● DATA DUMP REFERENCE	47

FRONT PANEL LAYOUT

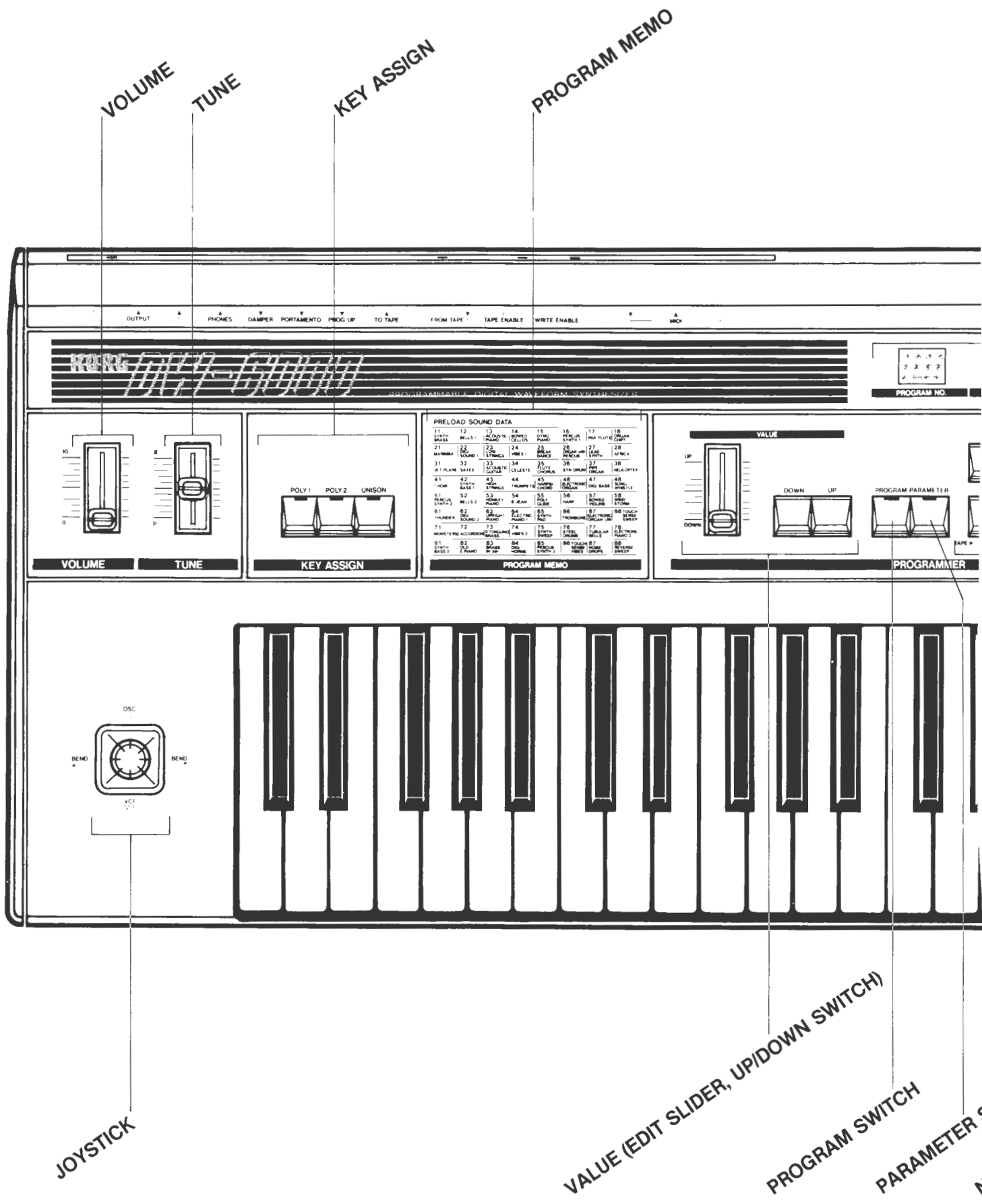

INDICATORS

OSCILLATOR WAVEFORM



POWER

PARAMETER LIST

OSC 1		OCTAVE	WAVEFORM	LEVEL							
11	16'	8'	4'	12	1--	8	13	0--	-31		
OSC 2		OCTAVE	WAVEFORM	LEVEL	INTERVAL	DETUNE	NOISE	LEVEL			
21	16'	8'	4'	22	1--	8	23	0--	-31		
VCF		CUTOFF	RESONANCE	KBD TRACK	POLARITY	EG INT	CHORUS	ON/OFF	ON/OFF		
31	0--	-63	32	0--	-31	33	0	1	2		
VCF EG		ATTACK	DECAY	BREAK P.	SLOPE	SUSTAIN	RELEASE				
41	0--	-31	42	0--	-31	43	0--	-31	44	0--	-31
VCA EG		ATTACK	DECAY	BREAK P.	SLOPE	SUSTAIN	RELEASE				
51	0--	-31	52	0--	-31	53	0--	-31	54	0--	-31
MG		FREQUENCY	DELAY	OSC	VCF						
61	0--	-31	62	0--	-31	63	0--	-31	64	0--	-31
BEND		OSC	PORTAMENTO	TIME							
71	0--	-12	72	0	73	0--	-31				
MIDI		CHANNEL	NOTE DATA	ENABLE	ORBI						
81	1--	-16	82	1	2	83	0	0	1	1	

OSC WAVEFORM

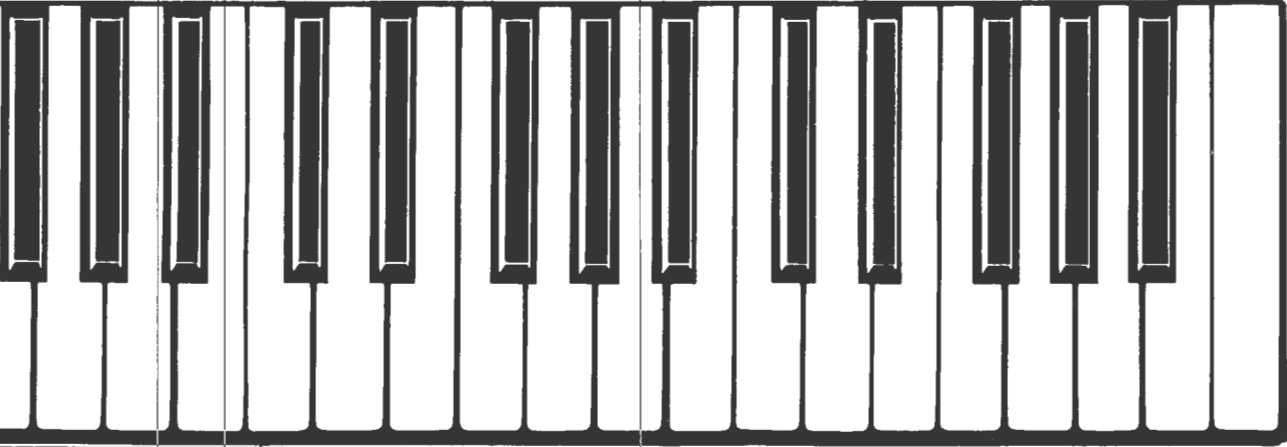
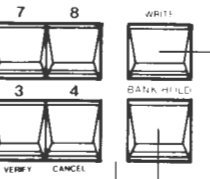
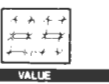
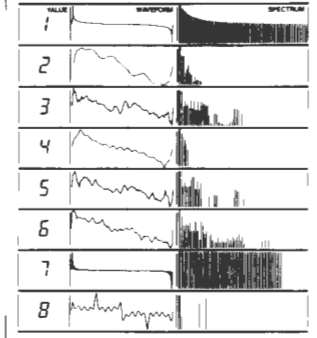

SELECT BUTTONS
4: SAVE/LOAD/
VERIFY/CANCEL)

BANK HOLD SWITCH

PROGRAM WRITE SWITCH

PARAMETER LIST

REAR PANEL LAYOUT

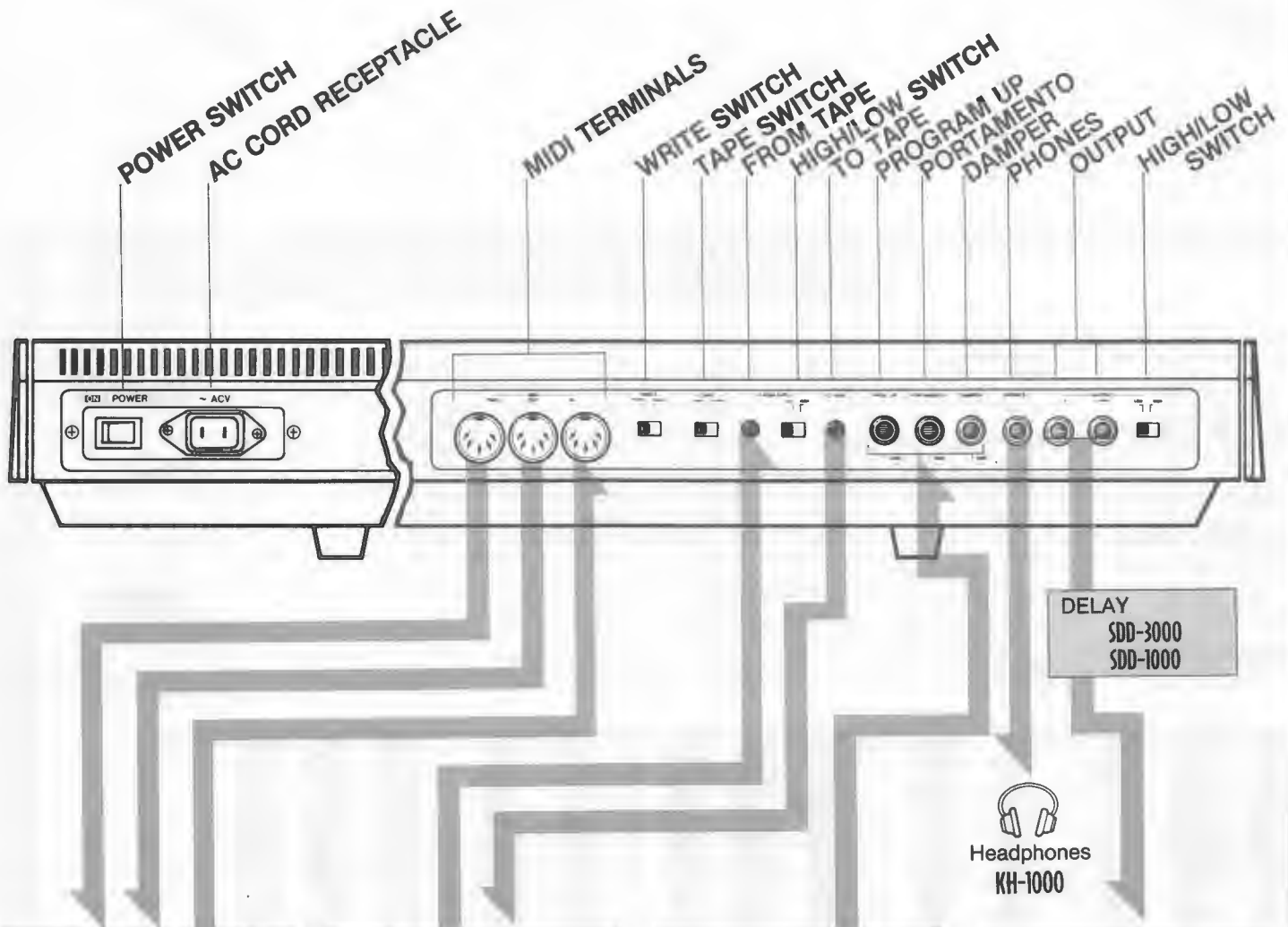

MIDI equipped synthesizers, sequencers, or computers.

POLY-800 EX-800 etc.

Computer

Tape decks, radio-cassette recorders, or tape recorders.

(with recording and playback functions)

Footswitch

PS-1
(GND type footswitch)

Mixers, amplifiers, or stereo systems.

KMX-8

MM-25

DW-6000 OVERVIEW

The DW-6000 uses a new digital method of sound generation called "Digital Waveform Generator System" or DWGS. Korg developed DWGS to provide a higher level of realism and richness together with the ease of operation of conventional analog processing.

What is DWGS?

Conventional synthesizers use VCOs or DCOs which produce simple waveforms such as the typical sawtooth, triangle, pulse, square, etc., found on normal synthesizers. However, to obtain the richness of real instrument sounds, you need a more complex harmonic structure than these conventional waveforms provide. Korg's DWGS uses eight digitally encoded waveforms having the complex harmonic structures required for professional music. These waveforms are based on actual samples of real musical instrument sounds (violin, acoustic piano, electric piano, saxophone, etc.), recreated by additive harmonic synthesis. The DW-6000 uses two DWGS oscillators per voice so you can mix different waveforms in variable proportions to create even more complex and unusual sounds. What's more, the DW-6000 uses analog VCA and VCF modules so you retain the familiar operation of conventional synths. You get fast, predictable results without the programming and control difficulties of "digital" systems. On the DW-6000, synthesis is straightforward, following basic synthesizer theory of pitch, timbre, and volume parameters.

DW-6000 Basic Functions

This manual covers the following basic functions.

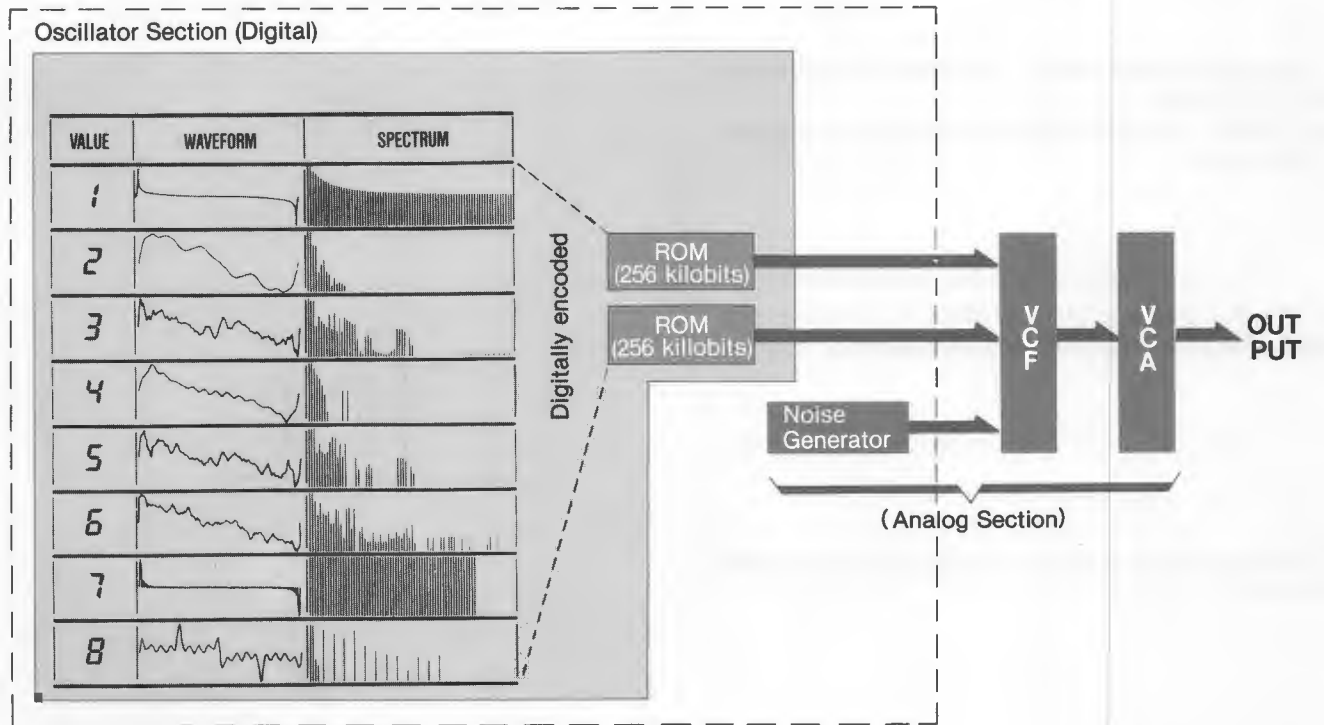
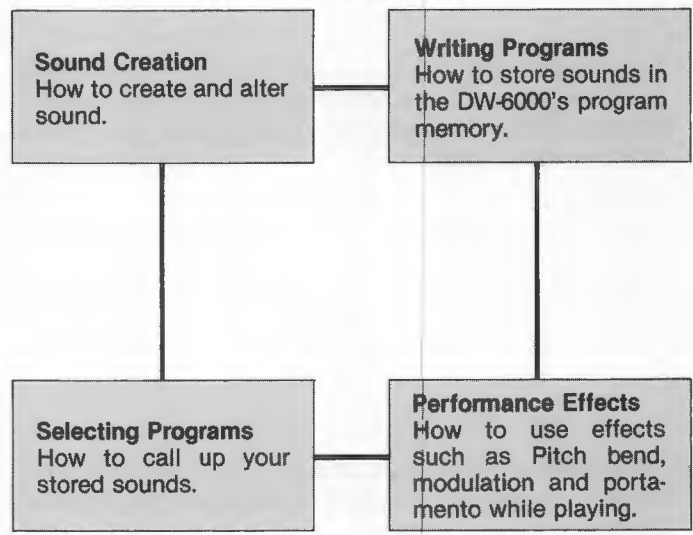

1. BASIC SETUP

Before using the DW-6000, follow these steps.

- 1 Make sure the power switch is off.
(The power switch is on the left side of the rear panel, as seen from the rear.)

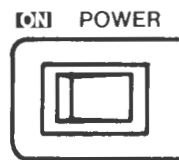

- 2 Plug the AC cord into a wall socket.

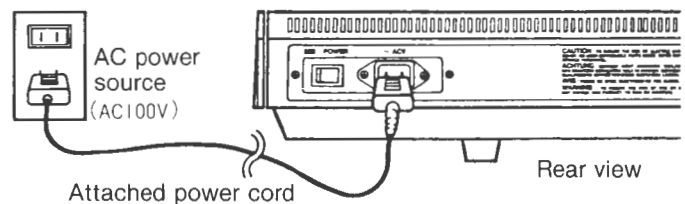

- 3 Turn down amplifier volume and connect the DW-6000 OUTPUT jack(s) to the amplifier or mixer input jack(s). Set the LOW/HIGH switch according to the kind of amp or mixer input used.

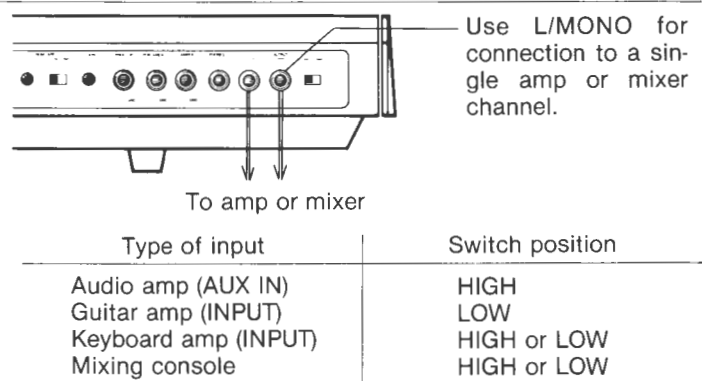

- 4 For operation without an amp or mixer, plug standard stereo headphone into the PHONES jack on the rear panel.

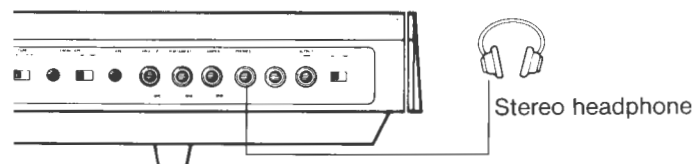

- 5 Be sure that the rear panel TAPE switch is set to the DISABLE position.
(If at ENABLE, you will not get any sound when you play the keyboard.)

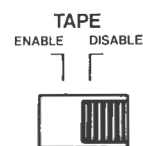

- 6 Turn on the power after everything is properly connected.) Be sure amplifier volume is down.)

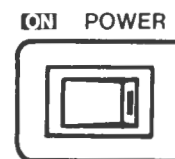

- 7 Adjust amp volume. Adjust volume control on DW-6000 front panel.

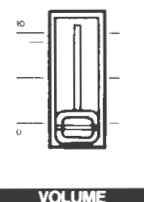

2. SELECTING PROGRAMS

This explains how to select any of the 64 different sounds stored in the DW-6000's memory. The PROGRAMMER section on the front panel is used for this purpose.

Features & Functions

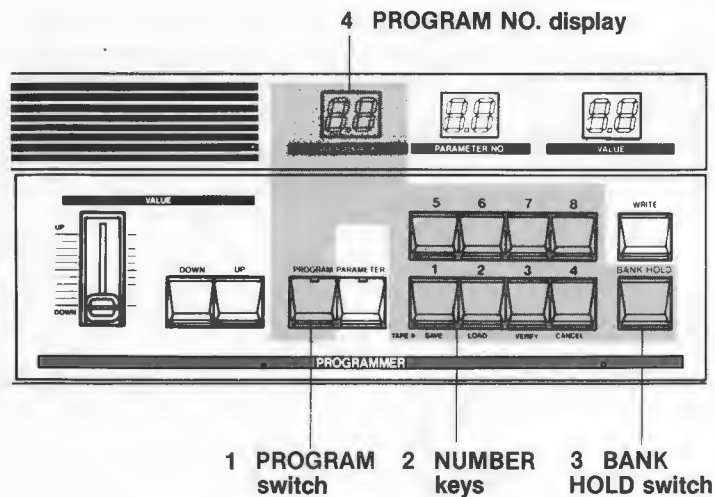

1 PROGRAM switch

When this switch is activated (and its LED indicator is on), different programs may be selected using the NUMBER keys.

2 NUMBER keys

Press these keys to specify program numbers, which range HRs from 11 through 88. Programs are arranged in eight "banks," signified by the left digit, with eight programs per bank, signified by the right digit; $8 \times 8 = 64$ total programs.

3 BANK HOLD switch

This holds the left "bank" digit so that you can use single number keys to quickly access any of the eight program numbers within a single bank.

4 PROGRAM NO. display

Shows selected program number.

About Program Numbers

Every sound gets a program number.

Writing programs

The DW-6000 can store up to 64 different sound programs in its internal memory. Each of these programs has a number from 11 through 88 (the digits 0 and 9 are not used). When you want to store a sound, you must assign it a program number. When you want to recall that sound, you select it by the same program number.

Sound program memory (64 total)

Program number	11	12	13	14	15	16	17	18
11~18 (8)	11	12	13	14	15	16	17	18
21~28 (8)	21	22	23	24	25	26	27	28
31~38 (8)	31	32	33	34	35	36	37	38
41~48 (8)	41	42	43	44	45	46	47	48
51~58 (8)	51	52	53	54	55	56	57	58
61~68 (8)	61	62	63	64	65	66	67	68
71~78 (8)	71	72	73	74	75	76	77	78
81~88 (8)	81	82	83	84	85	86	87	88

Selecting programs

You select the program number of the sound that you want to play or edit.

2 SELECTING PROGRAMS

How to Select a Program Number

When you first turn on the DW-6000's power, the display will appear as shown here and the PROGRAM LED indicator will be on.

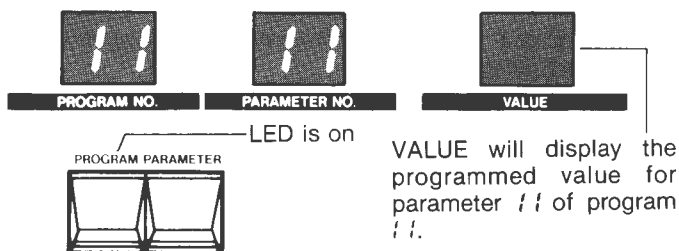

Now if you play the keyboard you will hear the sound of program number 11. Adjust the volume and see what it sounds like.

To select other programs:

- 1 Press the PROGRAM switch (if not already on). An LED will light above the switch.



- 2 Press the NUMBER keys to select any program number (11 ~ 88).

Example: To select program number 23...

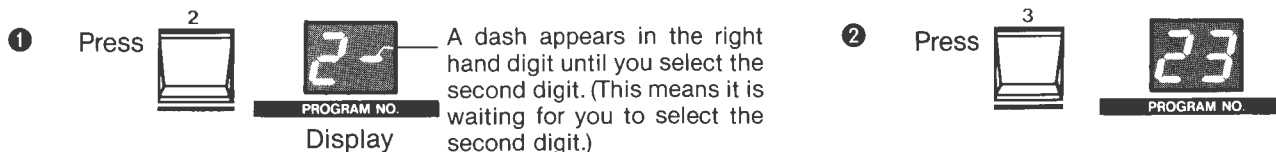

BANK HOLD

If you turn on the BANK HOLD switch the left digit (bank number) will be "locked." Depressing NUMBER keys will now only change the right digit "program number." This is the fastest way to select different programs within a bank.

- 1 Pressing the BANK HOLD switch preserves the left digit of the selected program number.

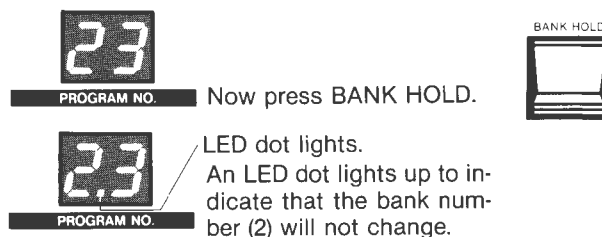

- 2 Now if you press any of the NUMBER keys, only the right hand digit will change.

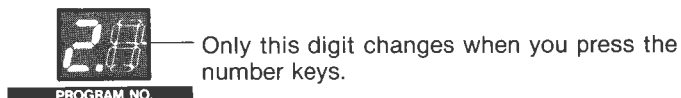

- 3 When you want to change to a program number in a different bank, press the BANK HOLD switch again to cancel BANK HOLD. You can now enter both digits using the NUMBER keys.

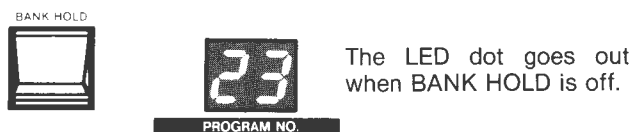

DW-6000

6 VOICE POLYPHONIC SYNTHESIZER MIDI IMPLEMENTATION CHART

Function		Transmitted ENABLE: DISABLE	Recognized ENABLE: DISABLE	Remarks
Basic Channel	Default Changed	 ×	Back up Last Number 1 - 16	
Mode	Default Messages Altered	 × *****	 OMNI ON/OFF	ignored
Note Number	: True voice	36-96 *****	0 - 127 24 - 108	If the data except these range were received, the data will be transposed to same note on the nearest octave.
Velocity	Note ON Note OFF	× 90 V=64 : × × 80 V=64 : ×	× : × × : ×	
After Touch	Key's Channel	× : × × : ×	× : × × : ×	
Pitch Bender		○ : ×	○ : ×	
Control Change	1 2 7 64 65	○ : × ○ : × × : × ○ : × ○ : ×	○ : × ○ : × ○ : × ○ : × ○ : ×	Pitch Modulation VCF Modulation Volume Damper Pedal Portamento Switch
Program Change	: True #	○ 0-63 : × *****	○ 0-127 : × 0-63	0=11, 7=18, 8=21 56=81, 63=88
System Exclusive		○ : ×	○ : ×	
System Common	: Song Position : Song Select : Tune	× : × × : × × : ×	× : × × : × × : ×	
System Real Time	: Clock : Commands	× : × × : ×	× : × × : ×	
Aux Messages	: Local ON/OFF : All notes OFF : Active Sensing : Reset	× × × ×	× ○ 123-127 × ×	Mode messages will be received always.
Notes		<p>When "NOTE DATA" designated by Parameter #82, all the recognized message except NOTE ON, NOTE OFF and Mode messages will be not received/transmitted.</p> <p>DISABLE: "NOTE DATA" designated by Parameter #82. ENABLE: "ALL" designated by Parameter #82.</p>		

Mode 1: OMNI ON, POLY
Mode 2: OMNI ON, MONO

Mode 3: OMNI OFF, POLY
Mode 4: OMNI OF, MONO

○ : Yes
× : No

3. CREATING SOUNDS

How to Make New Sounds

Features & Control Functions

1 KEY ASSIGN section

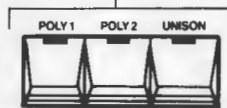

KEY ASSIGN

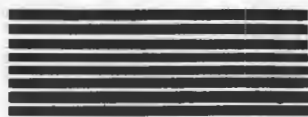

PROGRAM NO.



PARAMETER NO.



VALUE

8 PARAMETER NUMBER display 9 VALUE display

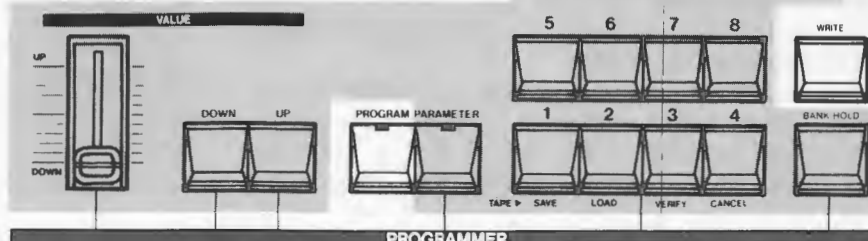

2 EDIT SLIDER

3/4 DOWN/UP keys

5 PARAMETER switch

6 NUMBER Keys

7 BANK HOLD switch

1 KEY ASSIGN section

The DW-6000 offers the user a choice of three different ways to assign voices from the keyboard (called "Key Assign Modes"): POLY1 is the "standard" polyphonic keyboard mode, for playing chords and melody lines.

POLY2 is intended particularly for portamento chord work. UNISON combines all voices and one note, for rich and fat soloing sounds.

2 EDIT SLIDER

Permits rapid and easy adjustment of parameter VALUES (aspects of the sound) over a wide range.

3/4 DOWN/UP keys

Press to change parameter values up or down a step at a time.

5 PARAMETER switch

When this switch is on, you can create and modify

sounds by selecting different parameters (using the NUMBER keys) and varying their VALUES (using the EDIT slider and/or DOWN/UP buttons).

6 NUMBER Keys

These keys are used to select different Parameter Numbers (when the parameter switch is on).

7 BANK HOLD switch

This holds the Parameter Number's left digit, so that the NUMBER keys can be used to select only the right digit. This can speed up Parameter Number selection when you are working on several parameters within the same "family" (that is, having the same left digit).

8 PARAMETER NUMBER display

Shows selected parameter number.

9 VALUE display

Shows current VALUE for selected parameter.

About the DW-6000's "Digital Access Control System"

The various aspects of a sound, such as its pitch, timbre and variations in volume, are called "Parameters." To create or change a sound, you adjust the values of each of these parameters.

On the DW-6000, there are 34 parameters per program; each parameter has a number, and each parameter's value is also represented by a number. These numbers are shown on the front panel display. To create or change a sound, you select parameters and change (or

"Edit") their values.

When the DW-6000 stores a sound in memory or calls it back from memory, it is actually storing and recalling the values you have given it for the sound's various parameters. All possible parameters and values are listed in the "parameter index" chart on the right side of the DW-6000 front panel. To create or change a sound, you first use the number keys to select a parameter number, then you use the edit slider and up/down keys to change its value.

Using the Parameter Index

PARAMETER LIST									
OSC1	OCTAVE	11 16' 8" 4'	12 1--8	13 0--31					
OSC2	OCTAVE	21 16' 8" 4'	22 1--8	23 0--31	24 1-3 3 4 5	25 0--6	26 0--31		
VCF	CUTOFF	31 0--63	32 0--31	33 0 1 2	34 7 2	35 0--31	36 0 7		
VCF EG	ATTACK	41 0--31	42 0--31	43 0--31	44 0--31	45 0--31	46 0--31		
VCA EG	ATTACK	51 0--31	52 0--31	53 0--31	54 0--31	55 0--31	56 0--31		
LMCL	FREQUENCY	61 0--31	62 0--31	63 0--31	64 0--31				
BEND	OSC	71 0--12	72 0	73 0--31					
MIDI	CHANNEL	81 1--16	82 1	83 0					

Example:

Changing the OSC1 (oscillator 1) waveform. Parameters related to OSC1 Here we have a choice of values from 1 to 8. Parameter number 12.

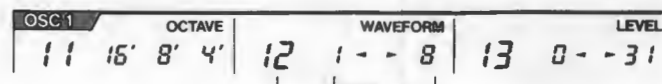

First select parameter number 12 (using the number keys with the parameter switch turned on). Then adjust the value (using the edit slider or up/down keys).

3 CREATING SOUNDS

The DW-6000 Approach to Sound Synthesis

To create new sounds on the DW-6000, you change or edit old programs. You do not start with a "blank slate". There are 64 sounds already in memory. If you have a new sound in mind, the easiest approach is to first select a sound that resembles the sound you want to create. Then "edit" (change the selected sound until you get the sound you want. If you don't find a similar sound, it doesn't matter; start with any sound you like.)

After you finish editing your sound, you store it into memory. This is called "writing a program to memory". At this point you can give it a different program number (thereby preserving the sound you started with) or the

same program (thereby erasing or "overwriting" the old sound).

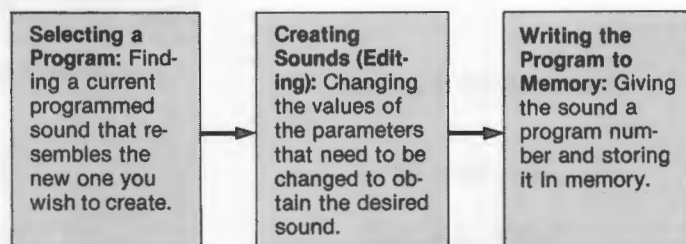

How to Make New Sounds

1 With the PROGRAM switch on, use the number keys to select programs and play the keyboard to find out what they sound like. Stop when you find one that resembles the new sound that you want to create.

2 Press the PARAMETER switch so that its LED lights up.

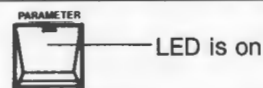

3 Refer to the parameter index chart to find the number of the parameter that you want to change. Press the number keys to select the desired parameter.

Example: Selecting VCF CUTOFF frequency. This is parameter number 31, so

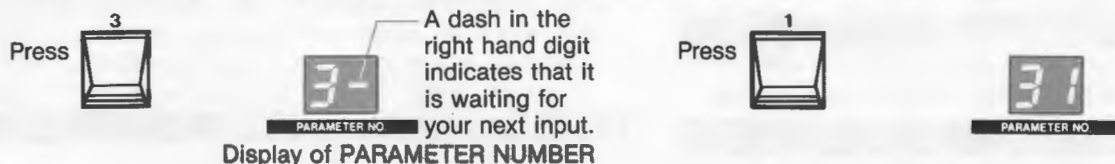

4 Use the Edit slider or change the parameter's value. Suggestion: Use the Edit slider to make large changes in value, then use the Up/Down keys to "fine tune" the sound. (VALUE display)

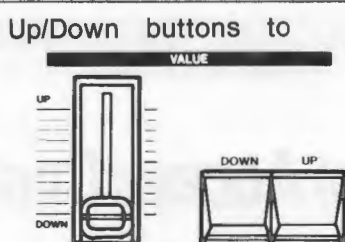

The LED dot in the corner of the VALUE display indicates that the value of the currently selected parameter has been changed. The dot goes out if you return to its original value.

5 Repeat steps 3 and 4 for each parameter that needs to be changed.

6 If you want to return to the original value of a parameter, just press both Up/Down keys at the same time.

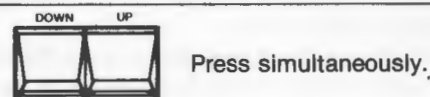

BANK HOLD

Often you will want to work on several parameters within the same "family", that is, having the same left digit. In such cases, turn on the BANK HOLD switch. This locks the left digit so that the NUMBER keys can be used to change the right digit only.

Example:

Select parameter number 31 (VCF cut off frequency), then press BANK HOLD.

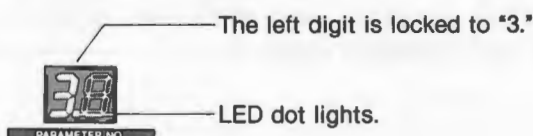

Now you can quickly access any of the parameters that pertain to the VCF section, (Resonance, EG Intensity, etc.) To release BANK HOLD, press the switch again. You may then select both digits of a parameter number.

★ To store your new sounds in memory, follow the operation procedures described in "WRITING PROGRAMS TO MEMORY" on page 23.

Parameters and Values

This section describes each module (such as Oscillator 1, VCF, etc.), its parameters (such as Octave, Waveform, etc.) and the results of using different values within each parameter.

OSC 1

OSC 1	OCTAVE	WAVEFORM	LEVEL
11 15' 8' 4'	12 1 - - 8	13 0 - - 31	

Parameters in this module determine the basic pitch range (OCTAVE) and timbre (WAVEFORM).

11 OCTAVE

Here you select the basic pitch range of oscillator 1. The higher the value, the lower the pitch. You have three choices which correspond to 15' (16 foot), 8', 4'.

VALUE	OCTAVE
4'	4' (high)
8'	8' (middle)
15'	16' (low)

13 LEVEL

Sets output level (volume) of oscillator 1. This is useful for adjusting overall volume to match other programs, and for balancing OSC1 with OSC2 and/or noise as desired.

VALUE	OUTPUT LEVEL
0	No sound from OSC1
↕	↕
31	Maximum volume

12 WAVEFORM

The choice of waveform will have more effect on the tonal characteristics (timbre or tone color) of the sound than will any other parameter. You have eight basic waveforms to choose from.

VALUE	WAVEFORM	SPECTRUM	INSTRUMENT FAMILY
1			Brass & Strings
2			Violin
3			Acoustic Piano
4			Electric Piano
5			Synth-Bass
6			Saxophone
7			Clavi
8			Bell & Gong

3 CREATING SOUNDS

OSC2

OSC 2	OCTAVE	WAVEFORM	LEVEL
21	15' 8' 4'	1 - - 8	23 0 - - 31
	INTERVAL	DETUNE	
24	1-3 3 4 5	25 0 - - 8	

This is your second sound source, designed to be used together with OSC1 to create thicker, richer and more complex sounds.

21 OCTAVE

As with OSC1, you have a choice of three pitch ranges: 4', 8', and 15'.

22 WAVEFORM

Once again, you have eight waveforms to choose from.

23 LEVEL

Adjusts output level as in OSC1

24 INTERVAL

This lets you transpose or offset the pitch of OSC2 so that it sounds a constant interval above OSC1. Selectable intervals are: Unison (same as OSC1), a minor 3rd, major 3rd, perfect 4th, or perfect 5th above.

VALUE	INTERVAL
1	Unison
-3	Minor 3rd
3	Major 3rd
4	Perfect 4th
5	Perfect 5th

* You will get different intervals (from those shown above) depending on the OCTAVE values for the two oscillators.

25 DETUNE

For fine pitch adjustment of OSC2 relative to OSC1. The higher the value, the greater the pitch difference between the two oscillators. Detuning can help achieve a fatter, more animated sound.

VALUE	PITCH DIFFERENCE
0	Minimum (no detuning—same pitch)
↓	↓
8	Maximum (about 25 cents)

NOISE

NOISE	LEVEL
26	0 - - 31

Provides white noise (a mixture of all frequencies) as a separate sound source. This is useful for adding "breath noise" to simulated acoustic instrument sounds, and for creating special effect sounds such as wind, surf, gunshot sounds, etc.

26 LEVEL

Adjusts noise volume.

VALUE	LEVEL
0	No noise
↓	↓
31	Maximum

VCF

VCF CUTOFF RESONANCE KBD TRACK POLARITY EG INT
 31 0--53 32 0--31 33 0 1 2 34 M W 35 0--31

This DW-60000s six voltage controlled filters (one per voice) remove or emphasize portions of the basic waveform harmonics. This affects the timbre of the OSC1, OSC2, and NOISE waveforms. These VCF are

low-pass filters, which remove frequencies above the selected CUTOFF frequency (while allowing lower frequencies to pass through).

31 CUTOFF

This determines the cutoff frequency of the low-pass filter. The higher the cutoff frequency, the less effect the filters have on the basic waveforms (since more frequencies are passed).

At the highest value, 53, all harmonics are passed. The lower the value, the more harmonics are cutoff, so the sound becomes progressively rounder or less bright.

Low-pass filter cutoff frequency.

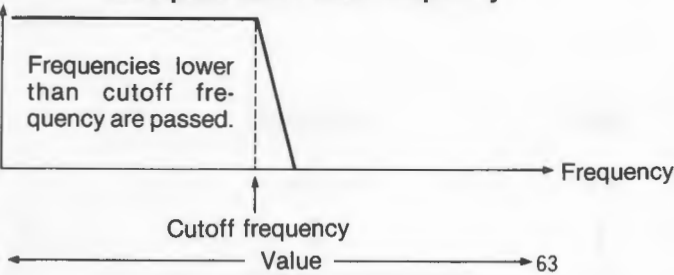

VALUE	TIMBRE
0	Dull or rounded
↕	↕
53	Bright, unchanged timbre

32 RESONANCE

This emphasizes the harmonics near the cutoff frequency, producing a characteristic peaky or bandpass type of sound.

The higher the value, the higher the resonance peak and the more obvious the effect. At or near the maximum value (31), the VCFs go into self-oscillation, producing a pure sine wave, which can be used as an additional sound source for special effects.

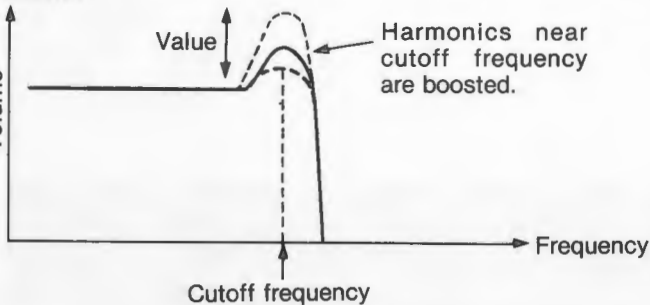

VALUE	EFFECT
0	None
↕	↕
31	Self-oscillation, very "peaky" sound.

33 KBD TRACK



Keyboard tracking affects how the cutoff frequency changes as you play notes higher or lower on the keyboard. At full tracking (VALUE = 2), cutoff rises in exact proportion to keyboard pitch, maintaining the same relative timbre for all notes, as is the case with most musical instruments. At half tracking (VALUE 1) it rises a half octave for every full octave on the keyboard. (The difference will be obvious if resonance is set to a high value.)

VALUE	KBD TRACK EFFECT
0 (off)	No change in cutoff frequency
1 (half)	50%
2 (full)	100%

3 CREATING SOUNDS

34 POLARITY

Determines how the VCF cutoff frequency is affected by the VCF EG (Envelope Generator). With normal polarity (VALUE = 1), the cutoff frequency rises during the EG's Attack and falls during Decay (as with most musical instruments); use "Inverted" polarity (VALUE = 2), for special sounds where you want the opposite effect.

VALUE	POLARITY
1	 <p>Cutoff frequency is swept up during the attack portion of the envelope, and down during the decay portion, etc.</p>
2	 <p>Cutoff frequency is swept down during the attack portion, and up during the decay portion of the envelope.</p>

35 EG INT

The "EG Intensity" parameter determines how much the VCF Envelope Generator (EG) will affect the cutoff frequency. The higher the value, the more obvious the change in tone color (timbre).

VALUE	INTENSITY
0	No effect
↑	↑
31	Maximum change in tone color.

CHORUS

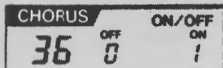

36 CHORUS

The built-in stereo chorus can be used to add warmth and ambience to sounds. It is especially effective when both outputs (R and L) are used for stereo reproduction, or listening through stereo headphones. Chorus can be set to On (1) or Off (0).

VALUE	EFFECT
0	OFF
1	ON

VCF EG, VCA EG

VCF EG	ATTACK	DECAY	BREAK P.	SLOPE	SUSTAIN	RELEASE					
41	0 - - 31	42	0 - - 31	43	0 - - 31	44	0 - - 31	45	0 - - 31	46	0 - - 31
VCA EG	ATTACK	DECAY	BREAK P.	SLOPE	SUSTAIN	RELEASE					
51	0 - - 31	52	0 - - 31	53	0 - - 31	54	0 - - 31	55	0 - - 31	56	0 - - 31

These two envelope generators control the “contour” (or changes over time, in terms of the sound’s attack, sustain, decay, and other dynamic characteristics) of each programmed sound. The VCF EG determines how the timbre, or brightness, changes over time. The VCA EG determines how volume changes over time. The DW-6000 utilizes advanced 6-stage EG modules with “break point” and “slope” rate parameters in addition to the conventional attack, decay, sustain and release parameters. Six parameters of ADBSSR envelope generators.

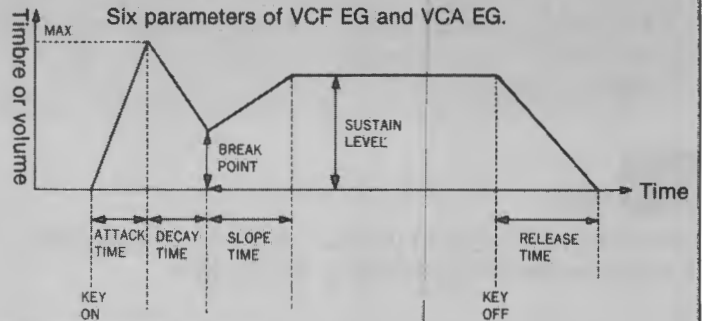

41 51 ATTACK (Rate)

Controls how long it takes for the volume or cutoff frequency to rise from zero to its maximum level after a note is played on the keyboard.

42 52 DECAY (Rate)

Determines how long it takes for the volume or cutoff frequency to fall from its maximum attack level to the break point level.

43 53 BREAK P. (Break Point Level)

Determines the level at which volume or cutoff frequency stops dropping during the decay. If this is set to the same value as the sustain level, then the envelope becomes a conventional ADSR type (as if it had no break point or slope parameters).

44 54 SLOPE (Rate)

Determines how long it takes for volume or cutoff frequency to change from the break point level to the sustain level. Note that if the break point is lower than the sustain level, then the slope functions as a second attack. If the break point is higher than sustain, then slope functions as a second decay.

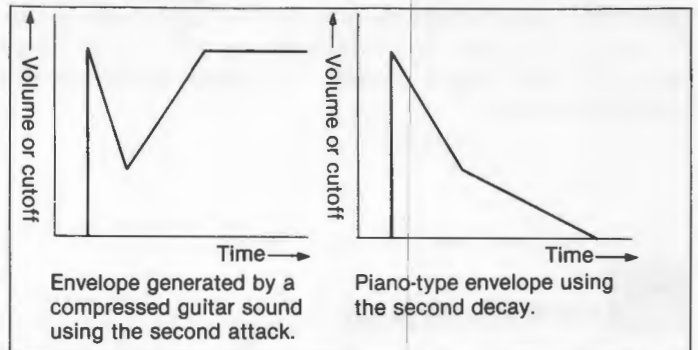

45 55 SUSTAIN (Level)

Determines the level at which volume or cutoff frequency is held after the attack, decay, and slope phases are completed, for as long as the note is held down on the keyboard.

46 56 RELEASE (Rate)

This determines how long it takes for the sound to fade away after you release the note on the keyboard.

VALUE	ATTACK	DECAY	BREAK P.	SLOPE	SUSTAIN	RELEASE
0	Short	Short	Low	Short	Low	Short
↑	↑	↑	↑	↑	↑	↑
31	Long	Long	High	Long	High	Long

In VCF EG, these changes are equal to the timbre, or brightness, change over time.

3 CREATING SOUNDS

MG

MG	FREQUENCY	DELAY	OSC	VCF
61	0 - - 31	62 0 - - 31	63 0 - - 31	64 0 - - 31

This stands for Modulation Generator. The MG section utilizes a low frequency oscillator to modulate the DW-6000's oscillator pitch (creating vibrato effects) and/or VCF cutoff frequency (creating filter mod or "wah-wah" effects).

61 FREQ

Determines the speed of the cyclic pitch or tonal variation. The higher the value, the faster the speed.

VALUE	SPEED of vibrato or wah-wah
0	Slow
↑	↑
31	Fast

62 DELAY

Determines the amount of delay following key depression prior to the onset of vibrato or other modulation effects. At 0, there is no delay, and modulation begins immediately when the first note is played. The higher the value, the longer the delay.

VALUE	DELAY TIME
0	None; modulation effect starts immediately
↑	↑
31	Long delay

63 PITCH (vibrato depth)

Controls the amount of pitch variation in the vibrato effect (that is, the depth of frequency modulation).

VALUE	VIBRATO DEPTH
0	No effect
↑	↑
31	Deep modulation

64 VCF (wah-wah depth)

Controls the depth of cyclic wah-wah effects (that is, the depth of VCF cutoff frequency modulation).

VALUE	WAH-WAH DEPTH
0	No effect
↑	↑
31	Deep modulation

BEND

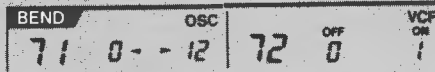

This module lets you determine the maximum change in pitch produced by the joystick. It also lets you choose whether or not the joystick will affect the VCF cutoff frequency. (See "Performance Features" for details.)

71 PITCH (bends)

Determines the maximum change in pitch produced by moving the joystick to the left or right, in exact semitone steps. The higher the value, the greater the pitch change (up to 1 octave).

VALUE	PITCH BEND
0	None (change in semitone steps according to the value)
↑	↑
12	1 octave

72 VCF

Enables or disables "sweeping" of the VCF cutoff frequency via the joystick. When this is on, you can use the joystick to change the brightness of sounds while playing.

	JOYSTICK VCF EFFECT
0	OFF
1	ON

When the VCF parameter value is 1 (ON) then moving the joystick to the right produces a brighter sound; moving it to the left produces a darker or duller sound.

PORTAMENTO

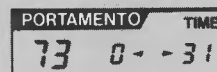

This module lets you produce a polyphonic note gliding effect at various rates. (See "Performance Features" for details.)

73 TIME (Portamento)

Determines how gradual the change in pitch is.

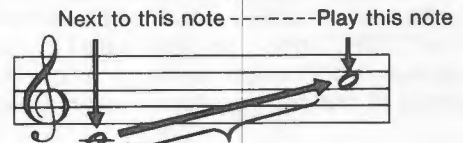

Portament effect (change in pitch from one note to the next.)

VALUE	PORTAMENTO TIME
0	No portamento effect (instant change)
↑	↑
31	Slow change in pitch from one note to the next.

3 CREATING SOUNDS

MIDI

MIDI	CHANNEL	NOTE DATA	ENABLE	OFF	OMNI
81	1 - - 16	82	1 2	83	0 1

The DW-6000 is a MIDI equipped synthesizer, and thus can control or be controlled by other MIDI equipped synthesizers, sequencers, rhythm machines and/or computers. The MIDI control parameters (parameters 81, 82 and 83) are not stored in program memory for

each program. Rather they can be set once for all programs. Except for the OMNI parameter (see below), the DW-6000's MIDI parameters retain their last value, even when power is turned off. (See MIDI section for further details.)

81 CHANNEL

This lets you choose the DW-6000's MIDI Receive channel, that is, the channel on which the DW-6000 will receive and obey information sent to it over MIDI. (When the DW-6000 is in the "OMNI" mode, as designated by parameter 83, it will receive information sent to it on ALL channels, regardless of the setting of the Channel parameter.)

VALUE	CHANNEL NO
1	CH 1
↕	↕
16	CH 16

82 ENABLE

This parameter determines what information received over MIDI the DW-6000 will respond to. At Value = 1, the DW-6000 responds to MIDI "note" data only. At Value = 2, it responds to all MIDI commands within its capabilities (such as Program change, modulation, etc.; see the MIDI data list at the back of this manual for a full listing of MIDI functions). The last setting of the ENABLE parameter is retained when power is turned off.

VALUE	Possible Transmit/Receive Data
1	only note DATA
2	all DATA

83 OMNI

This parameter determines whether the DW-6000 will respond to MIDI information on all channels, or on the channel specified by its Channel parameter (81). A value of 0 turns off the OMNI mode so that the DW-6000 responds to data sent on its assigned channel only (as selected by parameter 81). A value of 1 turns on the OMNI mode so that the DW-6000 responds to data on all channels.

The OMNI ON mode (Value = 1) is automatically selected when the DW-6000 power is turned on. OMNI OFF mode (Value = 0) is automatically selected whenever the Channel Parameter (Parameter 81) is selected by the user.

VALUE	OMNI MODE
0	OFF
1	ON

4. WRITING PROGRAMS TO MEMORY

This section explains how to store a sound after you have created it.

Features & Functions

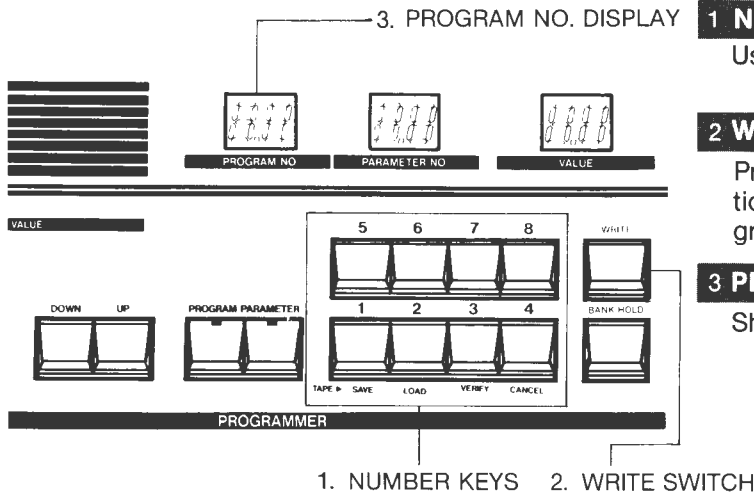

1 NUMBER Keys

Used to specify the program number

2 WRITE Switch

Pressing this switch enables a memory write operation so that you can store the currently sounding program in program memory.

3 PROGRAM NO. Display

Shows presently selected program number.

Which sections' settings can be stored in memory?

- The key assign section.

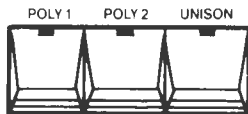

KEY ASSIGN

- All parameters except MIDI.

PARAMETER LIST

OSC 1	OCTAVE	WAVEFORM	LEVEL					
11	15' 8' 4'	12 1 - - 8	13 0 - - 31					
OSC 2	OCTAVE	WAVEFORM	LEVEL	INTERVAL	DETUNE	NOISE	LEVEL	
21	15' 8' 4'	22 1 - - 8	23 0 - - 31	24 1-3 3 4 5	25 0 - - 6	26	0 - - 31	
VCF	CUTOFF	RESONANCE	KBD TRACK	POLARITY	EG INT	CHORUS	OFF	ON/OFF
31	0 - - 63	32 0 - - 31	33 OFF HALF FULL 1 2	34 1 2	35 0 - - 31	36	0	1
VCF EG	ATTACK	DECAY	BREAK P.	SLOPE	SUSTAIN	RELEASE		
41	0 - - 31	42 0 - - 31	43 0 - - 31	44 0 - - 31	45 0 - - 31	46	0 - - 31	
VCA EG	ATTACK	DECAY	BREAK P.	SLOPE	SUSTAIN	RELEASE		
51	0 - - 31	52 0 - - 31	53 0 - - 31	54 0 - - 31	55 0 - - 31	56	0 - - 31	
MG	FREQUENCY	DELAY	OSC	VCF				
61	0 - - 31	62 0 - - 31	63 0 - - 31	64 0 - - 31				
BEND	OSC	OFF	VCF ON	PORTAMENTO	TIME			
71	0 - - 12	72 0	73 1	73	0 - - 31			

4 WRITING PROGRAMS TO MEMORY

Program Write Procedure

- 1 Create a sound (as described in the previous section of this manual).
- 2 Set the rear panel WRITE switch to the ENABLE position.

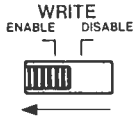

- 3 Press the WRITE switch (button) on the front panel.



At this point the display will show the originally selected program number, flashing on and off.



- 4 Use the NUMBER keys to select the program location where you want to store your sound.

Example:

Storing your sound at program number 34.

- 1 Press 3
 Display will show a dash in the right digit.

- 2 Press 4

Your sound now occupies the memory space called program number 34. The previous contents of this space have been erased.

Caution

Be sure to return the rear panel WRITE switch to the DISABLE position after completing this procedure. This helps protect against accidental overwriting (erasure) of memory contents.

Repositioning Sounds in Memory

If you always use particular sounds in the same order in a song or stage performance, then you can simplify your life by storing the sounds in the same order in which they will be used. That is, store your first sound under program number 1, the second sound under program number 2, and so on. You can then use a footswitch to advance from one sound to the next, as you need it. Sounds are repositioned by copying them from their present program number to a different program number.

- 1 Set the rear panel WRITE switch to the ENABLE position.



- 2 Use the NUMBER keys to select the program number of the sound that you want to reposition.

Example:

Copying the sound in program number 11 to another program number.

- 1 Turn on the PROGRAM switch.



- 2 Press the NUMBER keys to select program number 11.



- 3 Press the WRITE switch (button) on the front panel.



- 4 Use the NUMBER keys to select the program number where you want the sound to be located. Note that this erases the previous contents of the new program number. But it does not erase the contents of the old program number. That means that you now have the same sound at the old and new program number.

- 5 Follow steps 2 through 4 above, to rearrange your sounds in the order that is most convenient for performance.

5. PERFORMANCE FEATURES

TUNE

Used to tune the DW-6000 to match the pitch of other instruments.

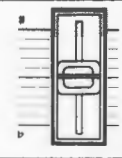

KEY ASSIGN

The DW-6000 has six separately articulated "voices" or "synthesizer modules." Different effects can be achieved by changing the way these are assigned to notes played on the keyboard. The KEY ASSIGN section gives you a choice of three ways of assigning voices to notes.

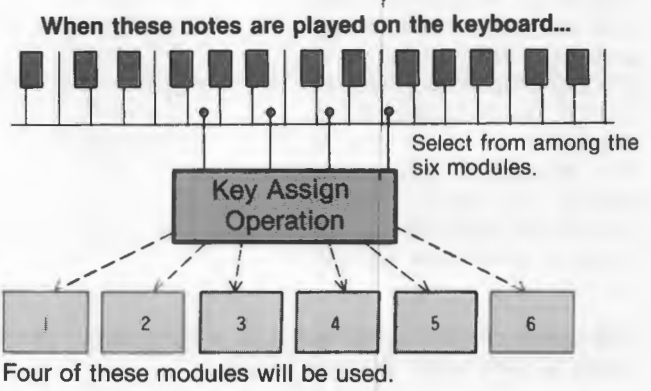
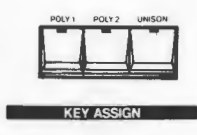

The KEY ASSIGN section controls which synth module is used to generate the sound of which note. Synth module 1

●POLY 1 Mode

This mode is used for normal polyphonic playing. The DW-6000's six voices are assigned sequentially as notes are played. If you play more than six notes, then the most recent notes will cancel out the earliest notes still sounding. In this mode, sounds using long release times will create an effect of "overlapping" notes, which will create a spacious sound.

Synth module 1

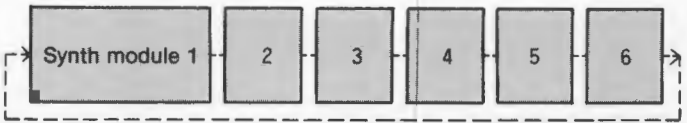

●POLY2 Mode

This is most useful for certain instrumental sounds, and for sounds using polyphonic portamento effects. If a one note passage is being played, one synth voice (out of six) is used continuously. If two notes are played, two voices are used continuously, and so forth.

Synth modules used.

When one note is played then the first module is always used.



When two notes are played then the first and second modules are always used.

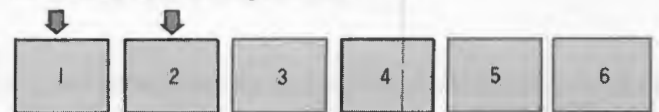

●UNISON Mode

This mode assigns all six voices to each key depression, following a "last note played" priority system, for monophonic soloing capabilities. Because all six voices are automatically detuned when this mode is selected, this produces a very fat, rich sound.

Synth modules used.

All modules are used for each note played.



When you write a sound program to memory, the selected key assign mode is stored along with your other parameter values. When you select that program number, the stored key assign mode will be automatically selected. You can, of course, temporarily change the Key Assign mode at any time while playing. But that alone does not change the stored Key Assign mode. Therefore, if you change key assign mode, then change to a different program number, then change back to the previous program number, you will get the stored key assign mode, not your latest key assign mode choice.

5 PERFORMANCE FEATURES

JOYSTICK

The joystick can be used for pitch bends and VCF cutoff frequency modulation (left and right movement). It can also be used to change vibrato and cyclic wah-wah intensity (up and down movement).

The amount of pitch bend during left-right joystick movement depends on the value of parameter number 71.

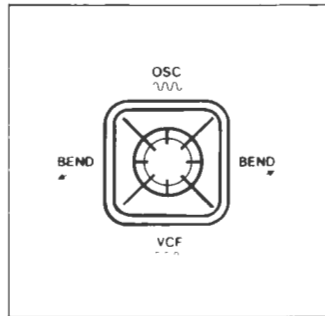

BEND OSC
71 0 - 12

VALUE	Change in pitch
0	None
↑ ↓	↕ (change in semitone steps according to the value)
12	1 octave

The speed of vibrato and wah-wah effects depends on the value of parameter 51 (MG FREQ)

MG FREQUENCY
51 0 - 31

VALUE	Vibrato or wah-wah speed
0	Slow
↑ ↓	↕
31	Fast

Parameter 72 (BEND VCF) determines whether left-right joystick movement will affect the VCF cutoff frequency. When the value is 1, then left movement lowers the cutoff frequency, producing a "darker" sound. Moving it to the right raises the cutoff frequency, giving a brighter sound.

72 OFF ON
0 1

VALUE	Effect of L/R joystick movement on VCF cutoff.
0	Disabled (no effect)
1	Enabled

To change the values of parameters, follow the steps described in the following section.

1 Depress the PARAMETER switch.



2 Use the NUMBER Keys to select the parameter that you want to adjust.

Example: To select parameter number 71...

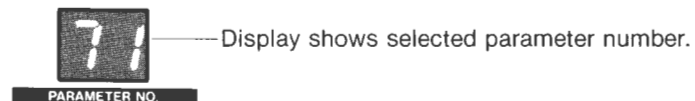

3 Use the edit slider and up/down keys (in the VALUE section) to change the parameter value.

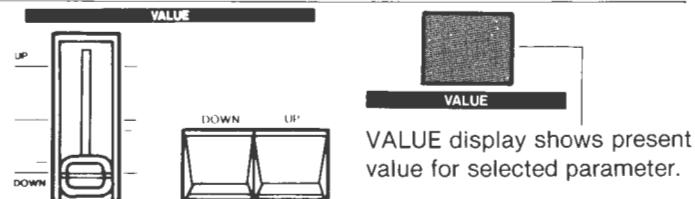

4 Depress PROGRAM switch and play keyboard.

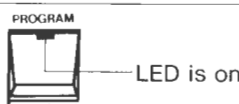

PROG UP (Program Up)

Connect a footswitch (such as the Korg PS-1) to this jack to enable convenient incrementing of the program number. Every time you press the footswitch, the program number advances one step. If BANK HOLD is on, then it advances within the bank (that is, the left digit does not change but the right digit goes in a loop from 1 up to 8 and then starts over from 1, etc.)

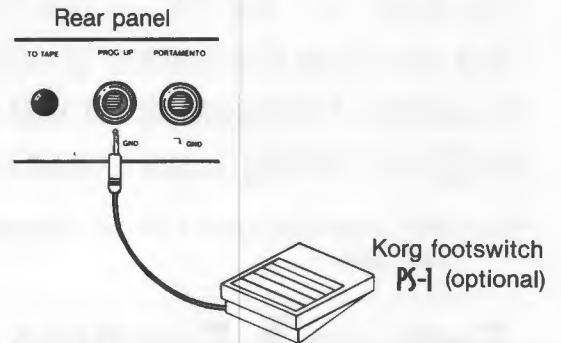

PORTAMENTO

Portamento is a gradual change in pitch from one note to the next.

●Portamento effect

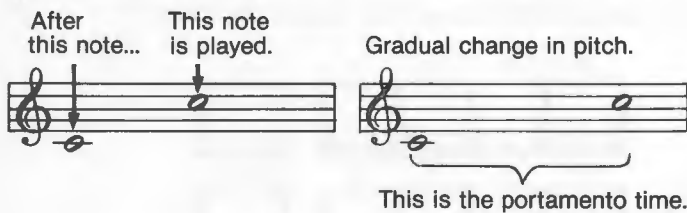

To use portamento, the PORTAMENTO parameter (73) value must be greater than 0.

PORTAMENTO	TIME	VALUE	PORTAMENTO TIME
73	0 - - 31	0	No effect
		↑	↑
		31	Maximum (most gradual pitch change)

To set the value of this parameter, follow the usual procedure of selecting the parameter number and your desired value (as described in the previous section).

If a foot switch is connected to the PORTAMENTO jack on the rear panel, then the portamento effect will be turned on for as long as the switch is kept depressed. When on, the portamento time will be the value selected in the portamento parameter (73).

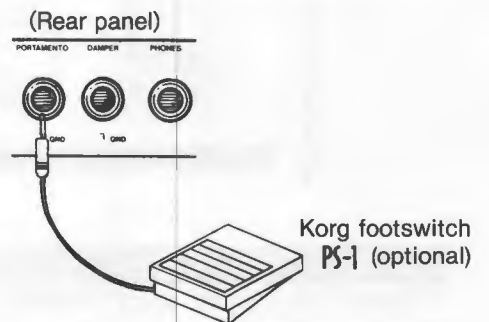

DAMPER

When a footswitch is connected to this jack, it can be used like a piano damper or "sustain" pedal. Depressing the footswitch has the same effect as keeping keys depressed on the keyboard.

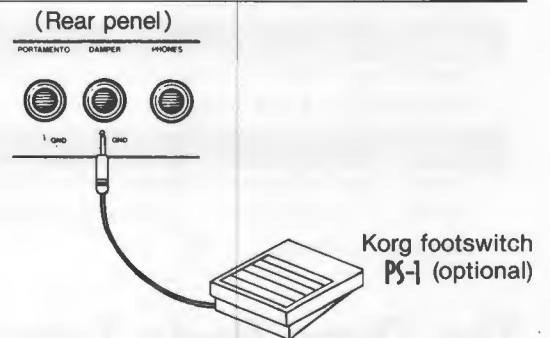

Example: EG responds as shown here.

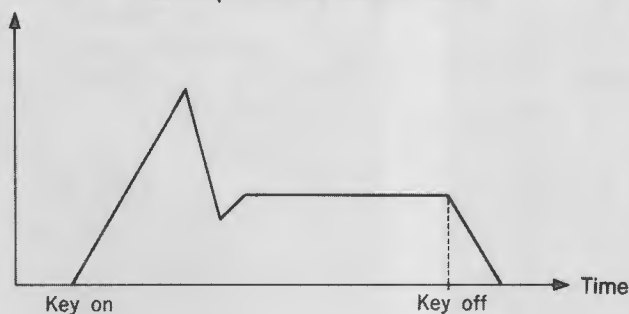

When the footswitch is pressed.

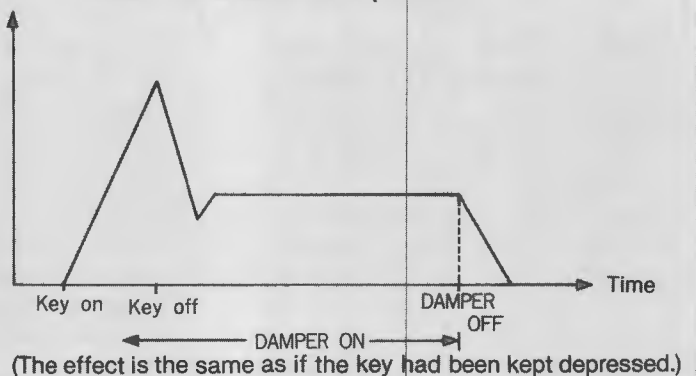

6. TAPE INTERFACE

The DW-6000 is equipped with a tape interface that lets you **SAVE** all sound program memory contents on cassette tape. Later you can **LOAD** the data from the tape back into the DW-6000 internal memory. The DW-6000 display keeps track of tape interface operations to help assure successful data transfer and detect possible problems. Operation is so fast (about 14 seconds) that you can even change your programs during a performance.

Note: MIDI parameter values are not included in tape interface operations. They cannot be saved on tape or loaded from tape.

Features & Functions

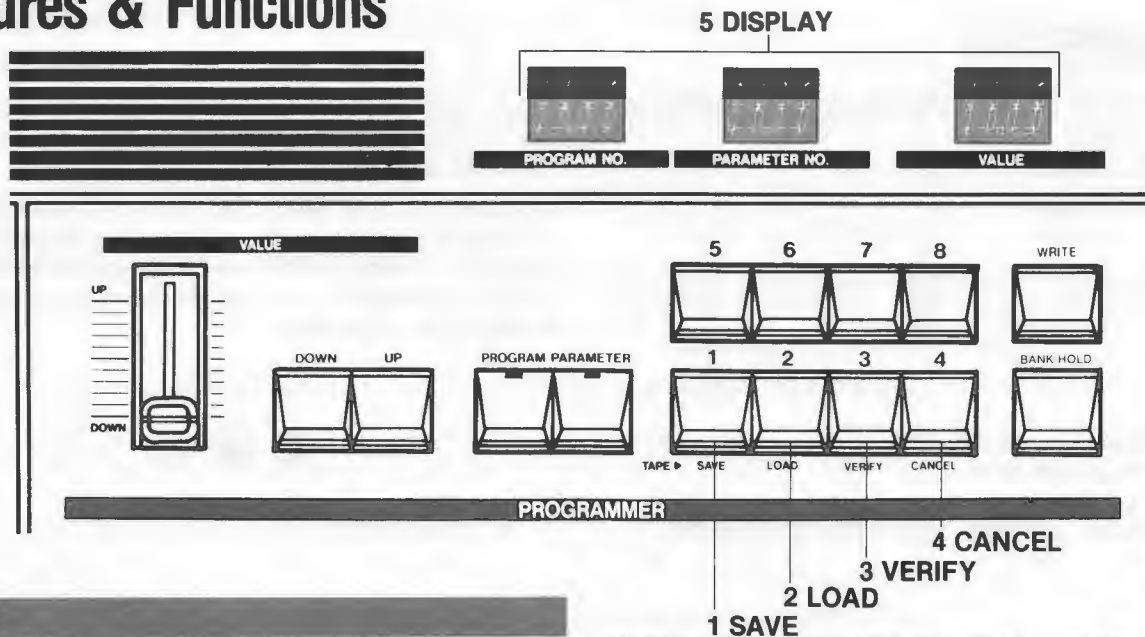

1 SAVE

Press this key to write DW-6000 program memory contents to your connected tape recorder.

2 LOAD

Press this button to read data from your tape recorder while playing back a tape.

3 VERIFY

This is used to check recorded data (immediately after the SAVE procedure) to make sure that it has been properly recorded on the tape.

4 CANCEL

If an error occurs during SAVE or LOAD operations, pressing this key lets you start over again. If you press the CANCEL key during SAVE, LOAD, or VERIFY operations, it will immediately interrupt and cancel the operation.

5 DISPLAY

This gives you messages to keep you informed of tape interface operations and possible problems.

The Three Basic Tape Interface Operations

1

SAVE

During a SAVE Operation, the DW-6000 sends all of its stored sound program data (the parameter values for all 64 program numbers) out the TO TAPE jack on the rear panel. The connected tape recorder is used to record this data during a SAVE operation.

2

VERIFY

This should always be performed immediately after a SAVE operation. VERIFY is used to check whether or not the SAVE operation has been successful. You play back the tape (through the FROM TAPE jack) that you have just SAVED the data on, and the DW-6000 checks to see whether it exactly matches the DW-6000 memory contents.

3

LOAD

During a LOAD operation, you play back a previously saved data tape (through the FROM TAPE jack), and the DW-6000 replaces the current program data with the data on tape.

Saving Program Data on Tape

Follow the procedures below to write DW-6000 program memory contents to your connected tape recorder.

- 1 Connect the DW-6000 rear panel TO TAPE jack to the microphone (mic) input jack on the tape recorder. (If the recorder has no mic jack, use a "line in" or other input jack.)
You may need a plug adaptor or special connection cord if the input jack is not the usual "mini jack" size.

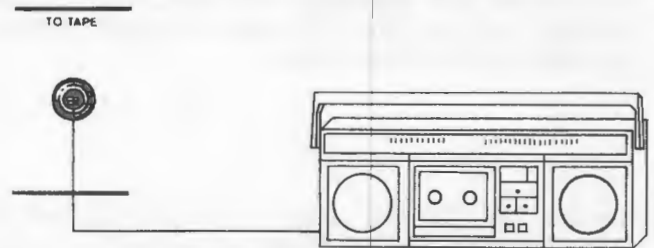

- 2 Set the DW-6000 rear panel TAPE switch to the ENABLE (ENA) position.

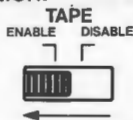

The DISPLAY will now appear as shown here.
This shows the the DW-6000 is in the tape interface mode.

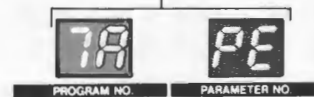

- 3 Prepare the tape recorder for recording. Begin recording and let the tape advance until it is past the leader tape (at the beginning of the cassette).

- 4 Press the recorder's pause key at the point from which you will begin recording data.
At this point, the DW-6000 is sending out a test tone as a reference for setting recording level (input level) on

the tape recorder. Adjust the tape recorder's recording level as you would normally (refer to tape recorder's instruction manual).

- 5 After setting recording level, release the pause key so that the recorder begins recording.

- 6 Press the SAVE key on the DW-6000.



The DW-6000 will start sending data and the DISPLAY will appear as shown here.



- 7 When the DISPLAY again shows TAPE, then you can stop the tape recorder.

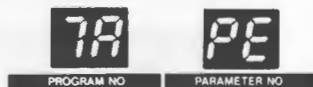

This completes the SAVE procedure. However, it is good practice to repeat the SAVE procedure several times, as a hedge against the possibility of losing data because of tape dropouts.

- 8 Reset the DW-6000 rear panel TAPE switch to the DISABLE position.



Do not change any settings on the DW-6000 until you complete the VERIFY procedure (in the following section).

A Word about Data Tones

If you listen to a tape of recorded data, you will hear the following tones:

- Level set tone (lower pitched "puu...")
- Leader tone (high-pitched "pee...")
- Data tone (medium-pitched "gaa...")
- End tone (high-pitched "pee...")
- Level set tone (lower pitched "puu...")

Leader tone: indicates the start of VERIFY and LOAD operations.

Data tone: The actual digital data from DW-6000 sound program memory.

End tone: indicates the end of the operation.

6 Tape Interface

VERIFY Procedure

The VERIFY procedure should always be used immediately after you finish a SAVE operation. This is to make sure that data has been properly recorded. It is also useful for determining the best playback level setting for your recorder.

- 1 Connect the DW-6000 rear panel FROM TAPE jack to the output jack (earphone, line out, etc.) of your recorder. Set the LOW/HIGH switch to match your tape recorder's output signal level.

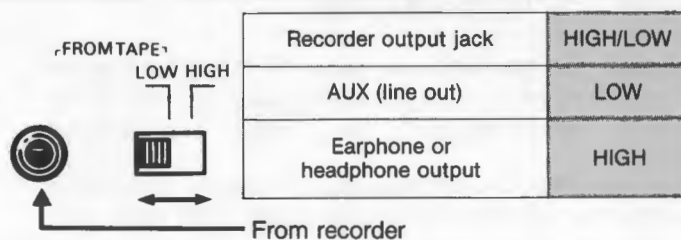

- 2 Set the DW-6000 rear panel TAPE switch to the ENABLE position. The DISPLAY will appear as shown here.



- 3 Set the tape recorder's playback volume a bit higher than usual. If the recorder has tone controls, set them to the center positions.

- 4 Rewind the tape. Begin tape playback. Stop the tape (using the stop or pause key) when you reach the beginning of the leader tone.

- 5 Press the VERIFY key on the DW-6000.



- 6 Start the tape recorder (press the play key or release the pause key). The DISPLAY will show "VERIFY" to confirm the VERIFY mode.

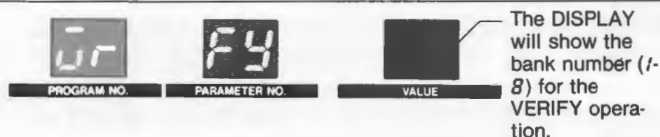

- 7 If the recorded data match the DW-6000 internal memory data then the DISPLAY will give a "Good" indication. The DISPLAY will appear as shown here if data is successfully verified.



- If you get an error (*Err*) message as shown here Press the CANCEL Key, lower (or raise) the tape recorder's output volume, and repeat steps 4-6.



- If the DISPLAY does not change after ten seconds of tape playback

Raise the tape recorder's output volume level and repeat steps 4-6.

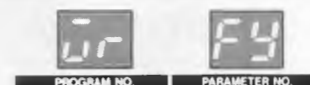

- 8 When you get a "Good" message, you can stop the tape recorder. Make a note of the recording level, playback level, and HIGH/LOW switch setting that resulted in the "Good" message.

- 9 Set the DW-6000 rear panel TAPE switch to the DISABLE position.

Note: You will not get a "Good" message if the recorded data is different in any way from the data in the DW-6000's internal memory. If you change a single parameter value or the key assign mode and then try VERIFY, you will get an error "Err" message.

If you still don't get a "Good" message after trying many different output level settings on the tape recorder (and HIGH/LOW switch settings on the DW-6000) then your recording level may be wrong. Try saving again at a different recording level.

LOAD Procedure

This procedure is used to put recorded data back into the DW-6000's internal memory.

- 1 Connect the DW-6000 rear panel FROM TAPE jack to the output jack (earphone, line out, etc.) of your recorder. Set the LOW/HIGH switch to match your tape recorder's output signal level.

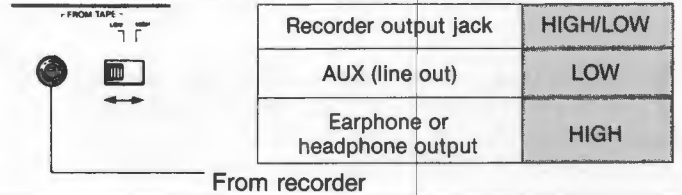

- 2 Set the DW-6000 rear panel WRITE switch and TAPE switch to the ENABLE (ENA) positions.

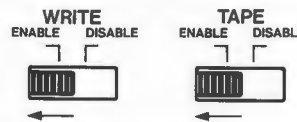

- 3 Set the tape recorder's playback volume to the level that produced a "Good" indication when you use the VERIFY procedure. If the recorder has tone controls, set them to the center positions.

- 4 Rewind the tape. Begin tape playback. Stop the tape (using the stop or pause key) when you reach the beginning of the leader tone.

- 5 Press the LOAD key.



- 6 Start tape playback (press the play key or release the pause key). The Display will appear as shown here.



- 7 If the data is successfully loaded into internal memory then the DISPLAY will give a "Good" indication.



The "Good" display indicates the completion of loading.

- If you get an error (*Err*) message as shown here Press the CANCEL Key, lower (or raise) the tape recorder's output volume, and repeat steps 4-6.



- If the DISPLAY does not change after ten seconds of tape playback Raise the tape recorder's output volume level and repeat steps 2-6.



- 8 When you get a "Good" message, you can stop the tape recorder.

- 9 Set the DW-6000 rear panel WRITE switches to the DISABLE positions.



Follow the VERIFY procedure to check if the data from the tape is precisely loaded on the programmer or not.

- 10 Set the DW-6000 rear panel TAPE switches to the DISABLE positions.

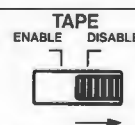

6 Tape Interface

Tape Interface Precautions

1 After a SAVE, LOAD, or VERIFY operation, reset the rear panel TAPE switch to DISABLE. If it remains set to ENABLE, the DW-6000 cannot be played.

2 If the tape recorder head is dirty, wow and flutter are excessive, or there are fluctuations in output (due to weak batteries, etc.), SAVE, LOAD, or VERIFY operation may not be correctly done.

3 When using a stereophonic tape recorder, use the left channel only for the SAVE operation. Otherwise, VERIFY and LOAD operations may not be done.

4 Do not vibrate the tape recorder by moving it or change the output level settings during SAVE, LOAD, or VERIFY operation. Otherwise, incorrect operation may result.

7.MIDI

MIDI (which stands for “Musical Instrument Digital Interface”) is a “universal language” adopted by most musical instrument manufacturers which allows MIDI equipped instruments to communicate and control each other, regardless of what company they are made by. The DW-6000 is MIDI equipped, so it can be connected to other MIDI equipped synthesizers, sequencers, rhythm machines, and personal computers.

HOW MIDI Works

(1) The MIDI Control System.

In the early days of electronic music, it was possible to “interface” (ie, interconnect) older monophonic synthesizers together by using two simple voltage signals. One was a CV (control voltage) signal that determined pitch. The other was a trigger signal that started and stopped each note.

But such techniques are too cumbersome and unreliable for today’s computerized polyphonic synthesizers. So the MIDI format was developed. In contrast to the older CV/Gate voltage signals, MIDI uses 8-bit digital words transmitted serially from instrument to instrument to communicate pitch, note on/off, and all kinds of information.

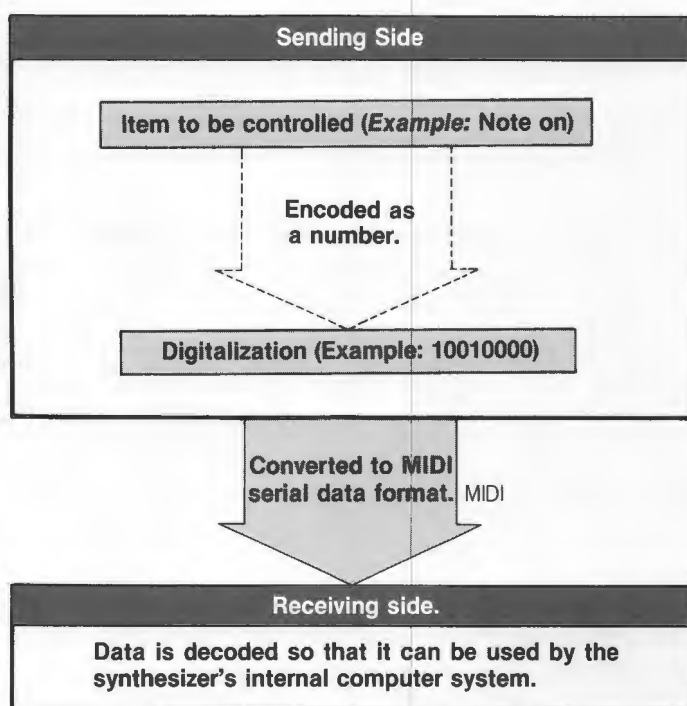

(2) MIDI Jacks and Connections.

All MIDI jacks are the same physically (using 5-pin DIN connectors). However, there are three kinds of MIDI jacks according to their purpose or application.

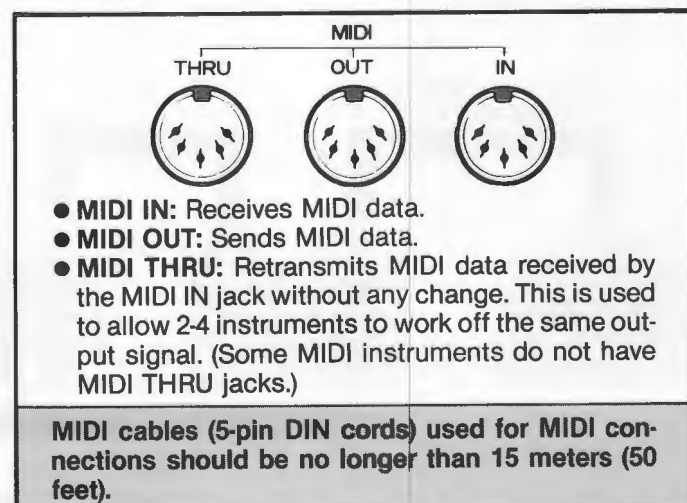

(3) MIDI Channels

If you are using more than two MIDI synths (or other MIDI units), then you can assign them different channel numbers (sort of like TV channels). There are 16 possible channels (designated as channel 1, channel 2, and so on) for sending and receiving.

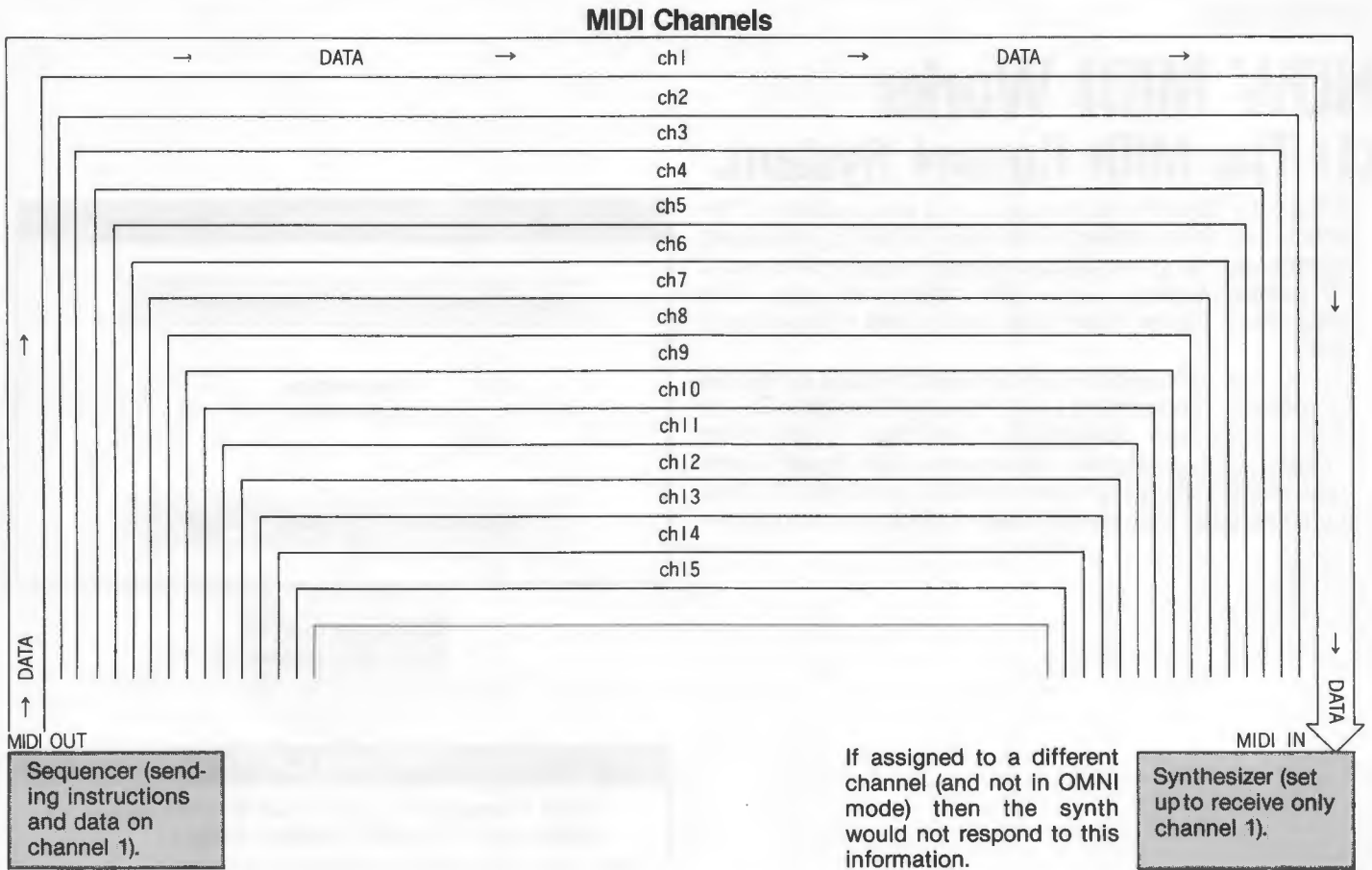

If you are using a MIDI sequencer or computer then you can assign particular instructions and data to particular channels. By assigning the various receiving synthesizers

and drum machines to different channels, you can make each instrument play a different part of your musical composition. This kind of complex MIDI system is shown here.

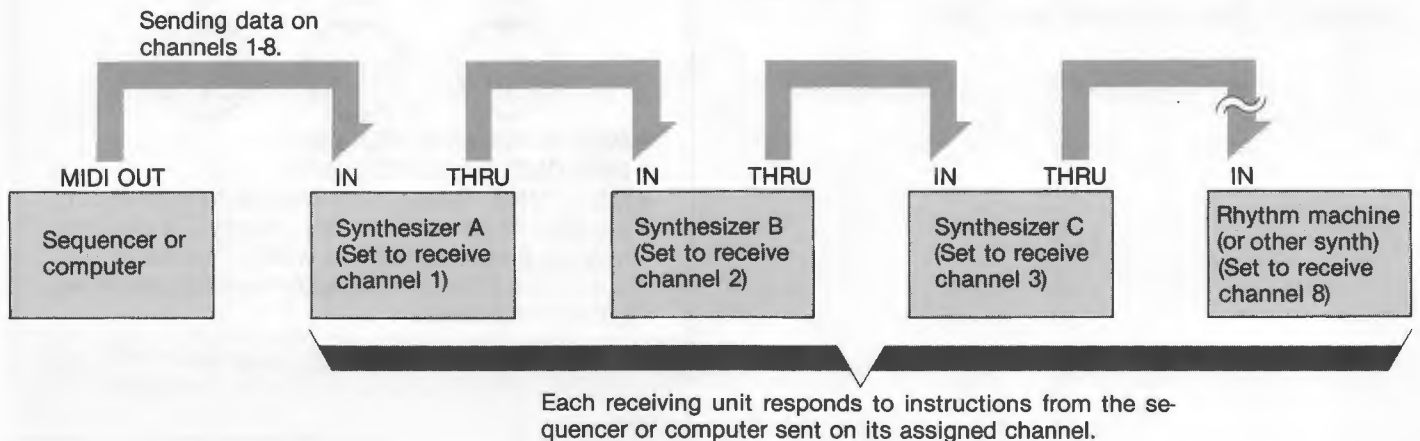

(4) Kinds of MIDI Data.

MIDI can be used to send many kinds of messages that contain instructions and information to be used by the receiving synthesizer and/or rhythm machines. The main kinds of MIDI data are described below.

1 CHANNEL VOICE MESSAGES

These tell the receiving synthesizer(s) which sounds to use, which notes to play, and when to start and stop playing those notes. They may also include instructions to use portamento, modulation, and other effects.

1 NOTE DATA

This information includes the notes to be played and when to start and stop playing them.

NOTE ON EVENT: This tells the receiving synth to start playing a note (equivalent to depressing a key on the keyboard).

NOTE OFF EVENT: This tells the receiving synth to stop playing a note (equivalent to releasing the key on the keyboard).

The NOTE DATA above also include the following information.

● NOTE NUMBER:

Every note has a number (representing the keys on a keyboard). This number tells the receiving synth which note to play.

VELOCITY: This determines how loud the note is played. (Not all synths can send or receive this data; however, no problems are created by mixing velocity and non-velocity sensitive keyboards.) The relationship between velocity value and "volume" is shown in the chart below.

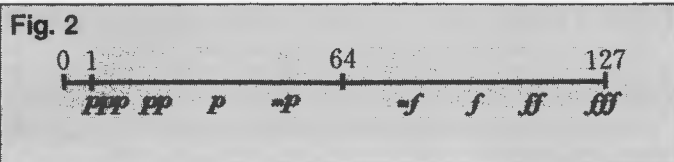
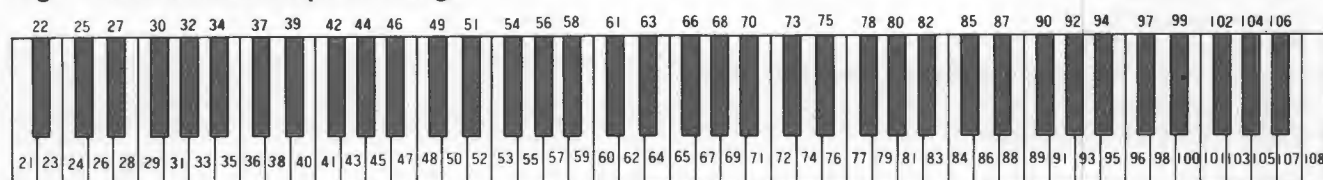

Fig. 1 Note number in piano range



2 PROGRAM CHANGES

This is used to select the sound program number to be used. Therefore, the receiving synth(s) can be made to change its sound by remote control.

3 CONTROL CHANGES

This can be used to control pitch bends, modulation, sustain (damper), portamento, and other effects.

4 PITCH BEND

This is used to control pitch bend effect.

2 CHANNEL MODE MESSAGES

These determine the channel mode used for communications.

1 OMNI MODE

When in the Omni mode, the receiving synths will respond to all information regardless of which channel it is sent on. When the Omni mode is off, a synth will respond only to data sent on its particular specified channel. If you turn off the Omni mode, then be sure that the sending synth is set to the same channel number as the receiving synth.

2 POLY MODE/MONO MODE

This determines whether note data will be handled as polyphonic (chords) or monophonic (one note played at a time).

In the poly mode, the receiving synth will, of course, be limited by the number of voices that it has.

In the mono mode, only one note will be played at a time, even if receiving multiple note data.

7 MIDI

3 SYSTEM REAL TIME MESSAGES

Used for synchronizing rhythm machines and sequencers. Includes tempo and start/stop data.

4 SYSTEM COMMON MESSAGES

Used when there are many MIDI units in a complex system. This can tell the units to start at the same time or get in tune with each other.

5 SYSTEM EXCLUSIVE MESSAGES

Can be used for passing data pertaining to one manufacturer's products (since each manufacturer has his own particular ID number). Usually used for program SAVE/LOAD and parameter-change operations.

All MIDI Synthesizers and other equipment use the same language for communication. But this does not mean that all units can send or respond to all information. For example, a synthesizer that does not have portamento capability will simply ignore MIDI data concerning that function. (The DW-6000, for example, ignores velocity data, but sends and receives portamento on/off information.)

DW-6000 MIDI Features

(1) Transmission/ Reception Received

The DW-6000 can send and receive the following kinds of MIDI data

1 Transmission

- Note data: note on/note off
- Program changes
- Pitch bend
- Pitch modulation
- VCF modulation
- Damper pedal On/Off
- Portamento On/Off
- System exclusive information

2 Reception

- Note data: note on/note off
- Program changes
- Pitch bend
- Pitch modulation
- VCF modulation
- Damper pedal On/Off
- Portamento On/Off
- Channel mode messages: (Omni-on, Omni-off, Poly, Mono, all-note-off)
- System Exclusive Information

See DW-6000 IMPLEMENTATION notes for details about system exclusive information.

(2) Features & Functions

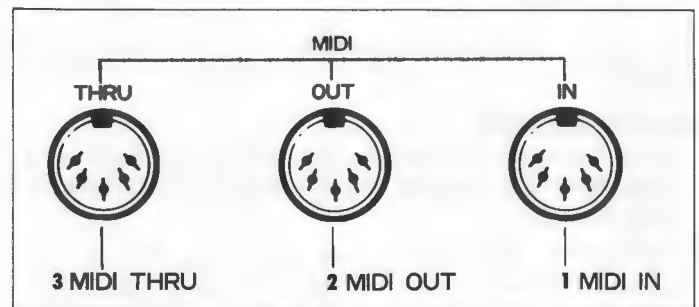

1 MIDI IN

Receives MIDI data.

2 MIDI OUT

Transmits MIDI data pertaining to the DW-6000.

3 MIDI THRU

Retransmits unchanged MIDI data received through the MIDI IN jack.

(3) Parameter and Value for MIDI

MIDI	CHANNEL	82	NOTE DATA	ENABLE	ALL	83	OFF	OMNI	ON
81	1 - - 16	82	1	2	83	0	0	1	1

81 CHANNEL

Selects the channel on which the DW-6000 will be able to receive MIDI data (when not in the OMNI mode).

The most recently selected channel number is retained by the DW-6000 when power is turned on and off. The DW-6000's Transmit channel is permanently set to CH-1.

VALUE	CHANNEL
1	CH-1
↑	↑
16	CH-16

82 ENABLE

This selects which kinds of received MIDI data the DW-6000 will send and receive (respond to). At value 1 (NOTE DATA), the DW-6000 sends and receives only "note data." At value 2 (All), it sends and receives all MIDI data specified in the DW-6000 MIDI specifications (implementation notes).

For example, if you don't want program numbers to be changed by some external device through MIDI, then set this value to 1.

VALUE	Kind of Data Sent/Received
1 (NOTE DATA)	note data only
2 (ALL)	All data

The most recently selected ENABLE value is retained when power is turned on and off.

83 OMNI

The Omni mode (value 1) is selected by default when the power is turned on. When the Omni mode is on, the DW-6000 receives MIDI data on all channels (regardless of the parameter 81 setting). However, the Omni mode can also be turned on and off from the controlling (sending) device. When the Omni mode is off, then the DW-6000 receives MIDI data sent only on the MIDI channel specified by parameter 81.

VALUE	OMNI MODE
0	OFF
1	ON

To change parameter values, follow the usual procedure as reviewed below.

- 1 Press the parameter switch so that its LED illuminates.

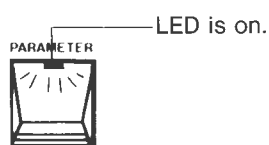

- 2 Use the NUMBER keys to select the desired parameter number.

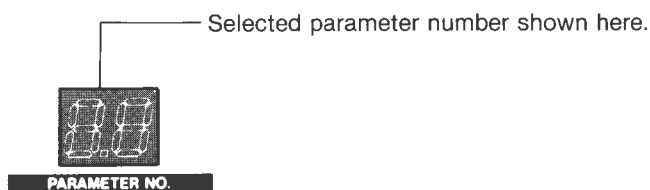

- 3 Use the Edit Slider and/or Up/Down keys (in the VALUE section) to set the parameter value.

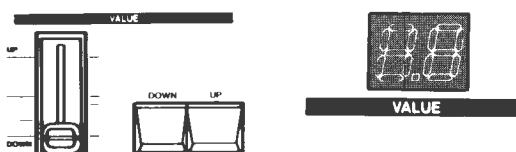

(4) Typical MIDI Setups

Using another MIDI synthesizer (Poly-800) to control the DW-6000.

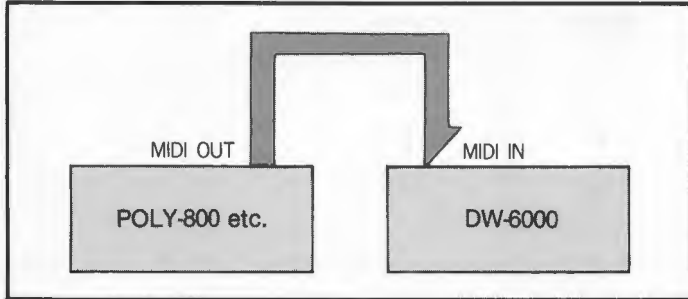

Connect Poly-800 (or other MIDI keyboard) MIDI OUT to DW-6000 MIDI IN jack using a MIDI cable (5-pin DIN cord). Connect the audio signal outputs of both units to amp or mixer inputs.

Notes played on the Poly-800 will also be sounded on the DW-6000. Joystick movement and program number changes will cause corresponding changes on the DW-6000 (if the ENABLE #82- parameter is set to ALL).

Experiment with different combinations of sounds (and detuning) on the two synths.

Using a Remote Keyboard.

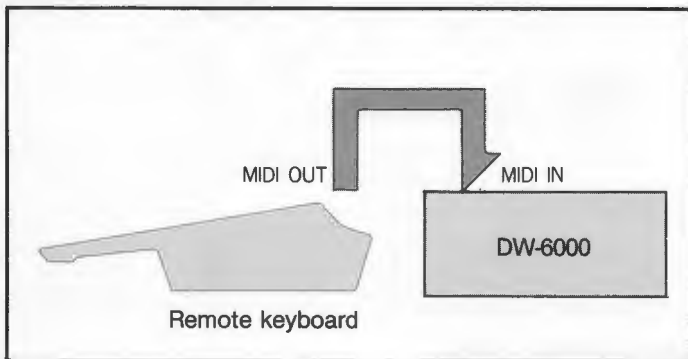

Connect remote keyboard (Korg RK-100, for example) MIDI OUT to DW-6000 MIDI IN jack. In this case you will want to use the remote keyboard to control everything including program number changes and joystick effects.

2-Way Control.

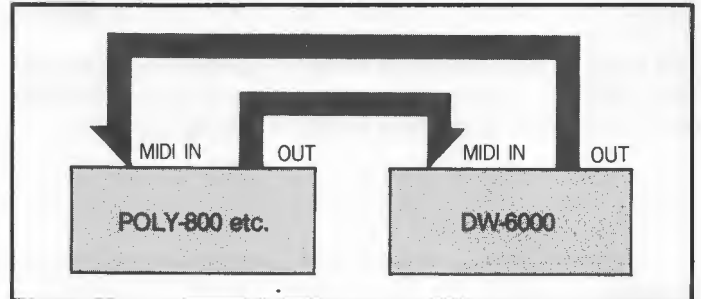

Here you need two MIDI cables to connect each synth's MIDI OUT to the MIDI IN of the other. The synth being played becomes the controlling (sending) synth.

Using a MIDI sequencer to control the DW-6000.

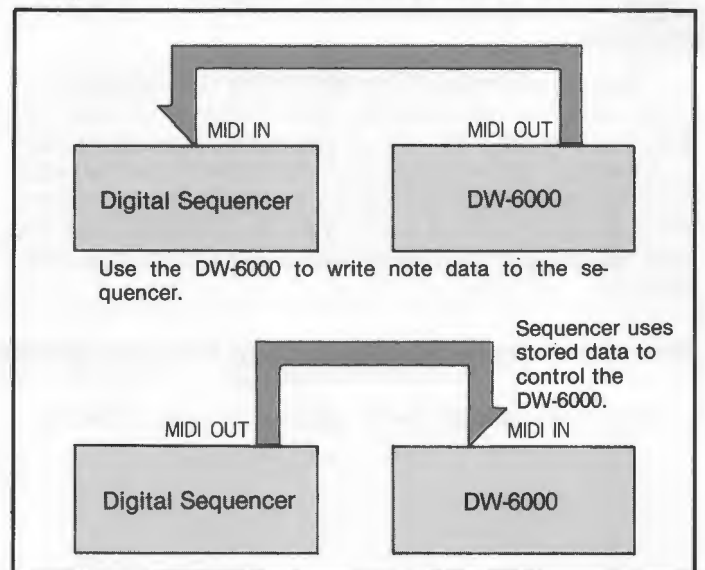

If using a digital sequencer, it is usually possible to program it in real time by simply playing on the DW-6000.

- 1 The DW-6000 sends note data to the sequencer. This stored note data can then be played back, reproducing the original note sequence on the DW-6000. (Refer to sequencer's instruction manual for details.)

Note that for programming, you have the DW-6000's MIDI OUT connected to the sequencer's MIDI IN. For playback, you have the sequencer's MIDI OUT connected to the synth's MIDI IN.

- 2 If using a multi-track digital sequencer, you can set the DW-6000 to receive on a particular channel and have it play a different part from other synth.

Using a Computer for Automated Performance.

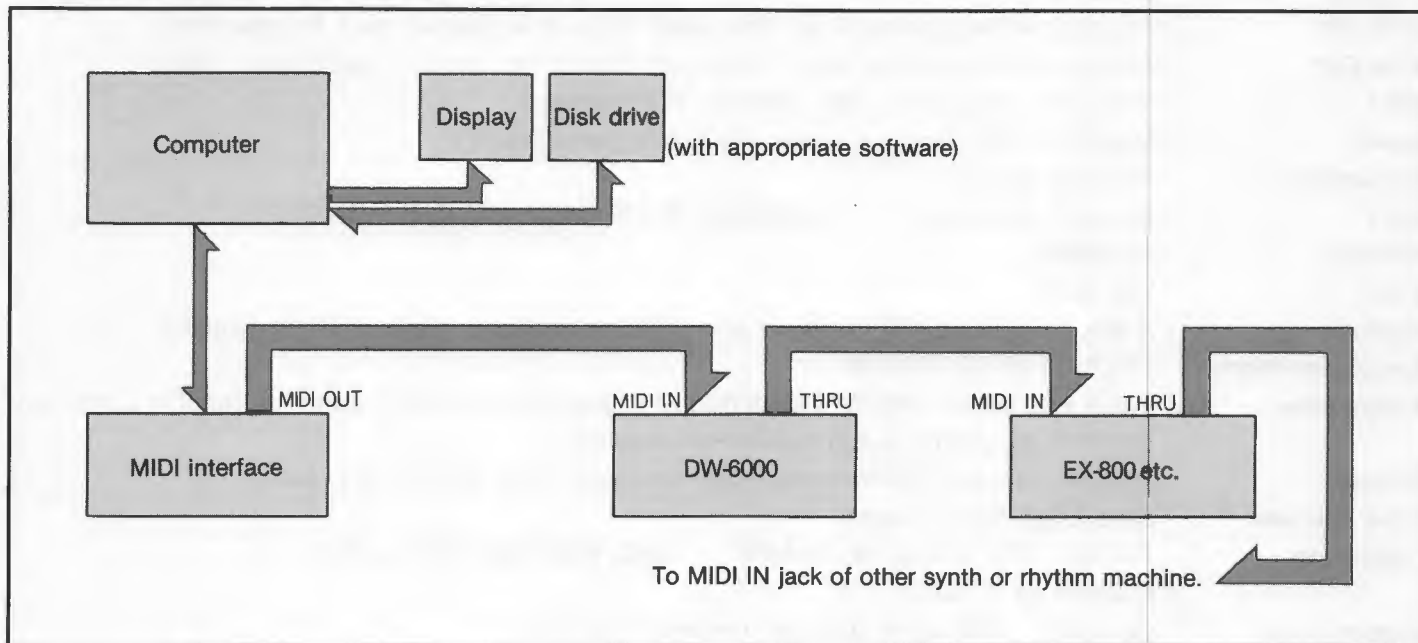

Software, such as Korg's new KSQ-800 4 Track MIDI Sequencer, is available for some computers to enable automated control of MIDI synths and drum machines. The interface is necessary to convert the computer output

to the proper MIDI signal format.

By using the MIDI THRU jack you can connect additional synths and rhythm machines.

■ The number of synths (and/or rhythm machines) connected in series using MIDI THRU jacks should be limited to two or three. Results may be unpredictable if more units are used. The solution is to use a parallel MIDI connection device such as the Korg KMT-60 MIDI THRU Box.

■ If the DW-6000 is being used in a MIDI connected system and starts producing erratic results (making a continuous sound, going out of tune, producing erratic modulation, etc.) press the front panel WRITE button. This resets the circuitry.

■ Be sure to read and follow the instructions for operation of all other equipment to be connected.

SPECIFICATIONS

Keyboard	: 61 keys (C ~ C)
Voice	: 6 Voice
OSC 1*	: Octave (16', 8', 4'), Waveform (1~8), Level adjustment
OSC 2*	: Octave (16', 8', 4'), Waveform(1~8), Interval (Unison, Minor 3rd, Major 3rd, Perfect 4th, Perfect 5th), Detune (24 cents MAX), Level adjustment
Noise*	: Level adjustment (White noise)
VCF*	: Cutoff Frequency, Resonance Keyboard Track (OFF, HALF, FULL), EG Polarity (∧, ∨), EG Intensity
Chorus*	: ON/OFF
VCF EG*	: Attack time, Decay time, Break Point level, Slope time, Sustain level, Release time
VCA EG*	: Attack time, Decay time, Break Point level, Slope time, Sustain level, Release time
MG*	: Frequency, Delay time, OSC intensity, VCF intensity
Bend*	: Maximum OSC Bend (±1 Octave MAX), VCF Bend ON/OFF
Portamnto*	: Portamento time
MIDI	: Receive Channel (ch 1 ~ 16), ENABLE (NOTE DATA/ALL), OMNI (ON/OFF)
Volume	: Adjustable
TUNE	: ±50 cents
Joystick	: X axis (OSC Bend, VCF Bend) +Y axis (OSC modulation) -Y axis (VCF modulation)
Key assign mode	: POLY 1, POLY 2, UNISON
Programmer	: Value (edit slider, UP/DOWN switches), PROGRAM/PARAMETER switches, Number select buttons (1 ~ 8), WRITE switch, BANK HOLD switch
Display	: Program Number, Parameter Number, Parameter Value, Bank hold indicator
Tape interface	: Save, Load, Verify, Cancel
Input jacks	: FROM TAPE (HIGH LOW), DAMPER (⏏GND) PORTAMENTO (⏏GND) : Program up (⏏GND)
Output jacks	: Output (R, L/MONO, HIGH/LOW), PHONES, TO TAPE
Tape switch	: ENABLE/DISABLE
Write switch	: ENABLE/DISABLE
MIDI jacks	: IN, OUT, THRU
Power supply	: Local voltage
Power consumption	: 34W
Weight	: 9.3kg
Dimensions	: 998 (W) × 338 (D) × 101 (H) mm
Accessories	: AC power cord, Connection cord, Data Cassette

(*Programmable)

OPTIONS

MIDI CABLE, LIGHT BAG, HARD CASE,
STAND ST-2B, PEDAL SWITCH PS-1, DYNAMIC STEREO HEADPHONES KH-1000

N O T I C E
Korg products are manufactured under strict specifications and voltages required by each country. These products are warranted by the Korg distributor only in each country. Any Korg product not sold with a warrantee card or carrying a serial number disqualifies the product sold from the manufacturer's/distributor's warrantee and liability. This requirement is for your own protection and safety.

MIDI IMPLEMENTATION

■ TRANSMITTED DATA

1. CHANNEL MESSAGE

STATUS	SECOND	THIRD	DESCRIPTION
1 0 0 0 0 0 0 0	0 k k k k k k k k	0 1 0 0 0 0 0 0	NOTE OFF (NOTE 1)
1 0 0 1 0 0 0 0	0 k k k k k k k k	0 1 0 0 0 0 0 0	NOTE ON (NOTE 1)
1 0 1 1 0 0 0 0	0 0 0 0 0 0 0 1	0 v v v v v 0 0	OSC MODULATION (NOTE 2)
	0 0 0 0 0 0 1 0	0 v v v v v 0 0	VCF MODULATION (NOTE 3)
	0 1 0 0 0 0 0 0	0 0 0 0 0 0 0 0	DAMPER PEDAL OFF
	0 1 0 0 0 0 0 0	0 1 1 1 1 1 1 1	DAMPER PEDAL ON
	0 1 0 0 0 0 0 1	0 0 0 0 0 0 0 0	PORTAMENTO OFF
	0 1 0 0 0 0 0 1	0 1 1 1 1 1 1 1	PORTAMENTO ON
1 1 0 0 0 0 0 0	0 p p p p p p p p	—	PROGRAM CHANGE ppppppp=0-63 (NOTE 4)
1 1 1 0 0 0 0 0	0 0 0 0 0 0 0 0	0 b b b b b b b b	PITCH BEND LSB 0-0-0 MSB 0-40H-7FH (NOTE 5)

NOTE

- NOTE NUMBER (0kkkkkkk) = 36 - 96.
- PITCH MODULATION range has 5 bits resolution (0vvvv00)
- VCF MODULATION range has 5 bits resolution (0vvvv00)
- PROGRAM NUMBER (0ppppppp) correspond to DISPLAY NUMBER on the PANEL which will be the following:

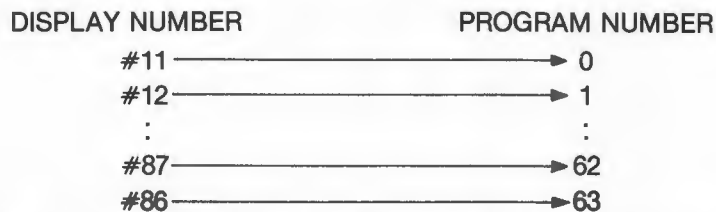

- PITCH BENDER range has 7 bits resolution (0bbbbbbb) only by MSB.

2. SYSTEM EXCLUSIVE MESSAGE

a DEVICE ID

BYTE	DESCRIPTION
1 1 1 1 0 0 0 0	EXCLUSIVE
0 1 0 0 0 0 1 0	KORG ID 42H
0 0 1 1 0 0 0 0	FORMAT .ID 30H
0 0 0 0 0 1 0 0	DW-6000 ID 04H
1 1 1 1 0 1 1 1	EOX

- If receive DEVICE ID REQUEST, DEVICE ID message will be sent.

b) WRITE COMPLETED

BYTE	DESCRIPTION
1 1 1 1 0 0 0 0	EXCLUSIVE
0 1 0 0 0 0 1 0	KORG ID 42H
0 0 1 1 0 0 0 0	FORMAT ID 30H
0 0 0 0 0 1 0 0	DW-6000 ID 04H
0 0 1 0 0 0 0 1	WRITE COMPLETED 21H
1 1 1 1 0 1 1 1	EOX

NOTE 7. If receive WRITE REQUEST and program write complete, WRITE COMPLETED message will be sent.

c) WRITE ERROR

BYTE	DESCRIPTION
1 1 1 1 0 0 0 0	EXCLUSIVE
0 1 0 0 0 0 1 0	KORG ID 42H
0 0 1 1 0 0 0 0	FORMAT ID 30H
0 0 0 0 0 1 0 0	DW-6000 ID 04H
0 0 1 0 0 0 1 0	WRITE ERROR 22H
1 1 1 1 0 1 1 1	EOX

NOTE 8. If received WRITE REQUEST and program write incomplete (when WRITE DISABLE is chosen on the rear panel), WRITE ERROR will be sent.

d) DATE SAVE(DATA DUMP)

BYTE	DESCRIPTION
1 1 1 1 0 0 0 0	EXCLUSIVE
0 1 0 0 0 0 1 0	KORG ID 42H
0 0 1 1 0 0 0 0	FORMAT ID 30H
0 0 0 0 0 1 0 0	DW-6000 ID 04H
0 1 0 0 0 0 0 0	DATA DUMP 40H
0 v v v v v v v	DATA 26bytes (SEE DW-6000 BIT MAP)
:	
0 v v v v v v v	
1 1 1 1 0 1 1 1	EOX

NOTE 9. If receive DATA SAVE REQUEST, DATA SAVE (DATA DUMP) will be sent.

MIDI IMPLEMENTATION

RECOGNIZED RECEIVE DATA

1. CHANNEL MESSAGE

STATUS	SECOND	THIRD	DESCRIPTION
1 0 0 0 n n n n	0 k k k k k k k	0 x x x x x x x	NOTE OFF (NOTE 11) velocity will be ignored.
1 0 0 1 n n n n	0 k k k k k k k	0 v v v v v v v	NOTE ON (0vvvvv>0)(NOTE 11) velocity will be ignored.
	0 k k k k k k k	0 0 0 0 0 0 0 0	NOTE OFF (NOTE 11)
1 0 1 1 n n n n	0 0 0 0 0 0 0 1	0 v v v v v x x	OSC MODULATION (NOTE 12)
	0 0 0 0 0 0 1 0	0 v v v v v x x	VCF MODULATION (NOTE 13)
	0 0 0 0 0 1 1 1	0 v v v v v v v	VOLUME (NOTE 14)
	0 1 0 0 0 0 0 0	0 0 0 0 0 0 0 0	DAMPER PEDAL OFF
	0 1 0 0 0 0 0 0	0 1 1 1 1 1 1 1	DAMPER PEDAL ON
	0 1 0 0 0 0 0 1	0 0 0 0 0 0 0 0	PORTAMENTO OFF
	0 1 0 0 0 0 0 1	0 1 1 1 1 1 1 1	PORTAMENTO ON
1 0 1 1 n n n n	0 1 1 1 1 0 1 1	0 0 0 0 0 0 0 0	ALL NOTES OFF
	0 1 1 1 1 1 0 0	0 0 0 0 0 0 0 0	OMNI OFF (ALL NOTES OFF)
	0 1 1 1 1 1 0 1	0 0 0 0 0 0 0 0	OMNI ON (ALL NOTES OFF)
	0 1 1 1 1 1 1 0	0 x x x x x x x	(ALL NOTES OFF)
	0 1 1 1 1 1 1 1	0 0 0 0 0 0 0 0	(ALL NOTES OFF)
1 1 0 0 n n n n	0 p p p p p p p	—	PROGRAM CHANGE (NOTE 15)
1 1 1 0 n n n n	0 x x x x x x x	0 b b b b b b b	PITCH BEND LSB will be ignored. MSB will be recognized.(NOTE 16)

- NOTE**
10. nnnn: 0-15. When the mode is OMNI ON, all the data will be received. When the mode is OMNI OFF, only data of the channel designated by Parameter #81 will be received. As to MODE MESSAGE, however, designated channel data only will be received even if the mode is OMNI ON.
 11. NOTE NUMBER (0kkkkkkk) = 24-108. If the data except above range were received, the data will be transposed to the same note on the nearest octave.
 12. PITCH MODULATION range has 5 bits resolutions (0vvvvxx) bit 0 - bit 1 will be ignored.
 13. VCF MODULATION range has 5 bits resolution (0vvvvxx) bit 0 - bit 1 will be ignored.
 14. VOLUME range has 7 bits resolution (0vvvvvv).
 15. PROGRAM NUMBER (0ppppppp) = 0 - 63. If the data is larger than 63, it will be recognized as a number which is taken 64 from it.
 16. PITCH BENDER range has 7 bits resolution (0bbbbbbb) only by MSB.

2. SYSTEM EXCLUSIVE MESSAGE

a) DEVICE ID REQUEST

BYTE	DESCRIPTION
1 1 1 1 0 0 0 0	EXCLUSIVE
0 1 0 0 0 0 1 0	KORG ID 42H
0 1 0 0 0 0 0 0	FORMAT ID 40H
1 1 1 1 0 1 1 1	EOX

b) WRITE REQUEST

BYTE	DESCRIPTION
1 1 1 1 0 0 0 0	EXCLUSIVE
0 1 0 0 0 0 1 0	KORG ID 42H
0 0 1 1 0 0 0 0	FORMAT ID 30H
0 0 0 0 0 1 0 0	DW-6000 ID 04H
0 0 0 1 0 0 0 1	WRITE REQUEST 11H
0 p p p p p p p p	PROGRAM NUMBER ppppppp=0-63
1 1 1 1 0 1 1 1	EOX

c) DATA SAVE REQUEST

BYTE	DESCRIPTION
1 1 1 1 0 0 0 0	EXCLUSIVE
0 1 0 0 0 0 1 0	KORG ID 42H
0 0 1 1 0 0 0 0	FORMAT ID 30H
0 0 0 0 0 1 0 0	DW-6000 ID 04H
0 0 0 1 0 0 0 0	DATA SAVE REQUEST 10H
1 1 1 1 0 1 1 1	EOX

MIDI IMPLEMENTATION

d) DATA LOAD(DATA DUMP)

BYTE	DESCRIPTION
1 1 1 1 0 0 0 0	EXCLUSIVE
0 1 0 0 0 0 1 0	KORG ID 42H
0 0 1 1 0 0 0 0	FORMAT ID 30H
0 0 0 0 0 1 0 0	DW-6000 ID 04H
0 1 0 0 0 0 0 0	DATA DUMP 40H
0 v v v v v v v v	DATA 26bytes (See DW-6000 BIT MAP)
⋮	
0 v v v v v v v v	
1 1 1 1 0 1 1 1	EOX

e) PARAMETER CHANGE

BYTE	DESCRIPTION
1 1 1 1 0 0 0 0	EXCLUSIVE
0 1 0 0 0 0 1 0	KORG ID 42H
0 0 1 1 0 0 0 0	FORMAT ID 30H
0 0 0 0 0 1 0 0	DW-6000 ID 04H
0 1 0 0 0 0 0 1	PARAMETER CHANGE 41H
0 v v v v v v v v	PARAMETER OFFSET (See DW-6000 BIT MAP)
0 v v v v v v v v	PARAMETER VALUE (See DW-6000 BIT MAP)
1 1 1 1 0 1 1 1	EOX

DATA DUMP REFERENCE



■ DW-6000 BIT MAP

PARAMETER OFFSET	PARAMETER VALUE							
	MSB b ₇	b ₆	b ₅	b ₄	b ₃	b ₂	b ₁	LSB b ₀
0	0	0	ASSIGN MODE		BEND OSC			
1	0	0	0	PORTAMENTO TIME				
2	0	0	0	OSC1 LEVEL				
3	0	0	0	OSC2 LEVEL				
4	0	0	0	NOISE LEVEL				
5	0	0	CUTOFF					
6	0	0	0	RESONANCE				
7	0	0	0	VCF EG INT				
8	0	0	0	VCF EG ATTACK				
9	0	0	0	VCF EG DECAY				
10	0	0	0	VCF EG BREAK P.				
11	0	0	0	VCF EG SLOPE				
12	0	0	0	VCF EG SUSTAIN				
13	0	0	0	VCF EG RELEASE				
14	0	0	0	VCA EG ATTACK				
15	0	0	0	VCA EG DECAY				
16	0	0	0	VCA EG BREAK P.				
17	0	0	0	VCA EG SLOPE				
18	0	0	BEND VCF	VCA EG SUSTAIN				
19	0	OSC1 OCT		VCA EG RELEASE				
20	0	OSC2 OCT		MG FREQ				
21	0	KBD TRACK		MG DELAY				
22	0	0	POLARITY	MG OSC				
23	0	0	CHORUS	MG VCF				
24	0	0	OSC1 WF			OSC2 WF		
25	0	0	OSC2 INTERVAL			OSC2 DETUNE		

DATA DUMP REFERENCE

■ DW-6000 BIT MAP AND CORRESPONDING PARAMETER VALUES

PARAMETER NAME	PARAMETER OFFSET	BIT	CORRESPONDING PANEL DISPLAY
ASSIGN MODE	0	b ₅ -b ₄	00 = POLY1 01 = POLY2 10 = UNISON 11 = INHIBIT

PARAMETER NAME	PARAMETER OFFSET	BIT	CORRESPONDING PANEL VALUE	PARAMETER NUMBER
BEND OSC	0	b ₃ -b ₀	0000~1100=0~12 1101~1111=INHIBIT	71
PORTAMENTO TIME	1	b ₄ -b ₀	00000~11111=0~31	73
OSC1 LEVEL	2	b ₄ -b ₀	00000~11111=0~31	13
OSC2 LEVEL	3	b ₄ -b ₀	00000~11111=0~31	23
NOISE LEVEL	4	b ₄ -b ₀	00000~11111=0~31	26
CUTOFF	5	b ₅ -b ₀	000000~111111=0~63	31
RESONANCE	6	b ₄ -b ₀	00000~11111=0~31	32
VCF EG INT	7	b ₄ -b ₀	00000~11111=0~31	35
VCF EG ATTACK	8	b ₄ -b ₀	00000~11111=0~31	41
VCF EG DECAY	9	b ₄ -b ₀	00000~11111=0~31	42
VCF EG BREAK P.	10	b ₄ -b ₀	00000~11111=0~31	43
VCF EG SLOPE	11	b ₄ -b ₀	00000~11111=0~31	44
VCF EG SUSTAIN	12	b ₄ -b ₀	00000~11111=0~31	45
VCF EG RELEASE	13	b ₄ -b ₀	00000~11111=0~31	46
VCA EG ATTACK	14	b ₄ -b ₀	00000~11111=0~31	51
VCA EG DECAY	15	b ₄ -b ₀	00000~11111=0~31	52
VCA EG BREAK P.	16	b ₄ -b ₀	00000~11111=0~31	53
VCA EG SLOPE	17	b ₄ -b ₀	00000~11111=0~31	54
BEND VCF	18	b ₅	0=0(OFF) 1=1(ON)	72
VCA EG SUSTAIN	18	b ₄ -b ₀	00000~11111=0~31	55
OSC1 OCT	19	b ₆ -b ₅	00=16 01=8 10=4 11=INHIBIT	11
VCA EG RELEASE	19	b ₄ -b ₀	00000~11111=0~31	56
OSC2 OCT	20	b ₆ -b ₅	00=16 01=8 10=4 11=INHIBIT	21
MG FREQ	20	b ₄ -b ₀	00000~11111=0~31	61
KBD TRACK	21	b ₆ -b ₅	00=0(OFF) 01=1(HALF) 10=2(FULL) 11=INHIBIT	33
MG DELAY	21	b ₄ -b ₀	00000~11111=0~31	62
EG POLARITY	22	b ₅	0=1() 1=2()	34
MG OSC	22	b ₄ -b ₀	00000~11111=0~31	63
CHORUS	23	b ₅	0=0(OFF) 1=1(ON)	36
MG VCF	23	b ₄ -b ₀	00000~11111=0~31	64
OSC1 WF	24	b ₅ -b ₃	000~111=1~8	12
OSC2 WF	24	b ₂ -b ₀	000~111=1~8	22
OSC2 INTERVAL	25	b ₅ -b ₃	000=1 001=-3 010=3 011=4 100=5 101~111=INHIBIT	24
OSC2 DETUNE	25	b ₂ -b ₀	000~110=0~6 111=	25

■ INTERFACE WITH PERSONAL COMPUTER

When using a computer for DW-6000 control and communications, a system exclusive message and the following data types are employed.

Sending	
DEVICE ID	: Identifies the equipment. Sent upon receiving a DEVICE ID REQUEST.
WRITE COMPLETED	: Sent in response to a WRITE REQUEST, this indicates that the PROGRAM WRITE task has been successfully completed.
WRITE ERROR	: Sent in response to a WRITE REQUEST, this means that the synth is set to the WRITE DISABLE mode so PROGRAM WRITE task cannot be completed.
DATA SAVE (DATA DUMP)	: In response to a DATA SAVE REQUEST, this sends the data for the sound presently being produced.

Receiving	
DEVICE ID REQUEST	: A request for the equipment's MIDI identification number.
WRITE REQUEST	: A request for the DW-6000 to write data for the present sound to program memory.
DATA SAVE REQUEST	: A request for the DW-6000 to send data for the present sound.
PARAMETER CHANGE	: Used to change parameters of the current sound.

The above examples require that the DW-6000 and computer interface be connected via their respective MIDI IN and MIDI OUT Jacks as shown here.

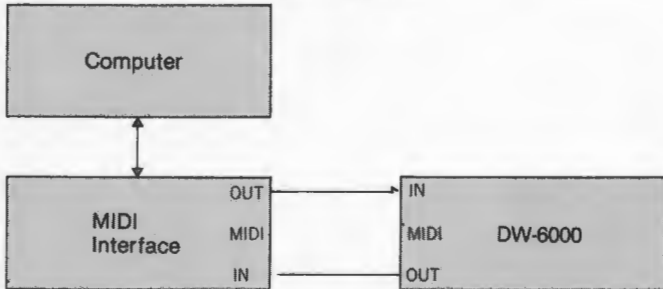

The above data types are used for communication in the following ways.

① To find the ID number for equipment connected to the computer.

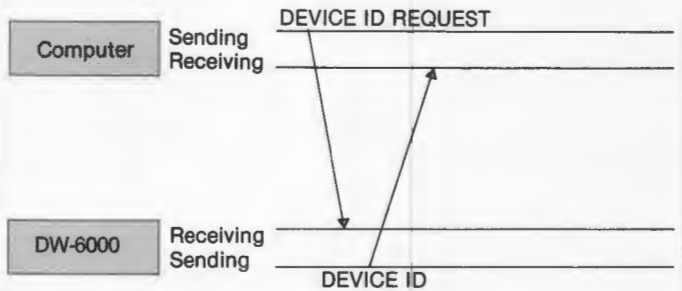

② To edit sound data within the DW-6000.

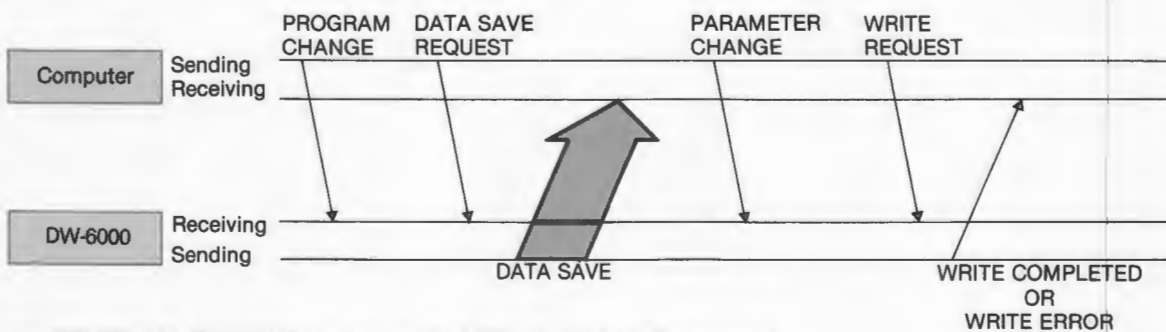

Note: PROGRAM CHANGE is not a SYSTEM EXCLUSIVE message.

③ To edit data already available in the computer.

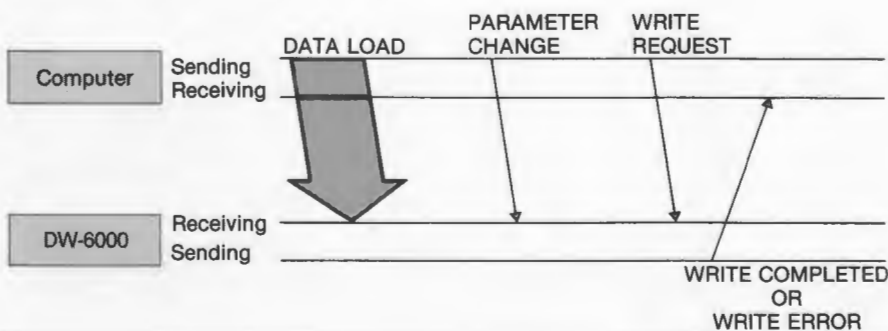

DATA DUMP REFERENCE

④ To load all 64 sound programs from the computer to the DW-6000.

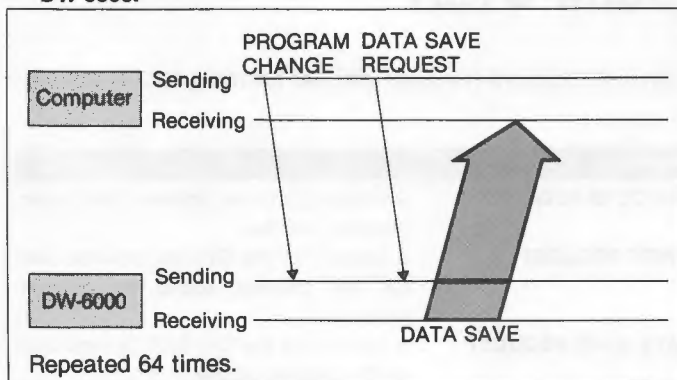

⑤ To save all 64 sound programs from the DW-6000 to the computer.

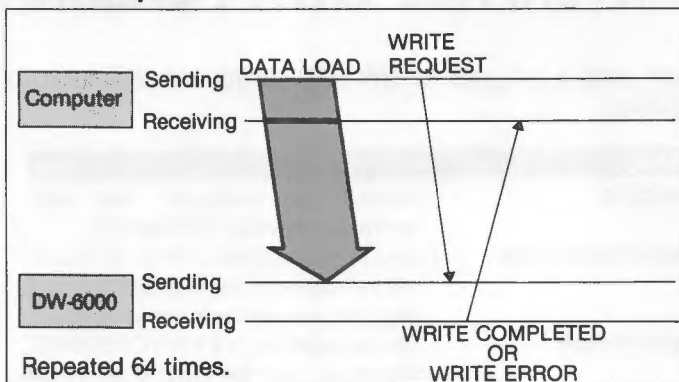

KORG Distributors List

ARGENTINA

Import Music S.A.
Beauchf 884, 1424 Capital Mohammedia

AUSTRALIA

Billy Hyde Music Pty., Ltd.
P.O. Box 472, 7 Union Street, South
Melbourne, Victoria 3205
Phone: (03) 690 6022

AUSTRIA

Weiss & Kadlec
Triester Strasse 261, 1232 Wien
Phone: 0222/674539

BAHRAIN

Marshall Boutique
P.O. Box No. 925, Government Road
Phone: 251664

BARBADOS

A & B Music Supplies Ltd.
Handley House, Prince Alfred St., Bridge Town
Phone: (809) 427-5384/429-5217

BELGIUM

Coninx Music Import
Grote Markt 5, 3600 Genk
Phone: (011)357736

BERMUDA

Riihiluoma's The Music Markers
Queen St. Black Stone 1617 Hamilton
Phone: (809-29) 50890

BRASIL

F. Purwin
Caixa Postal P.O. Box 14.475
22412 Rio de Janeiro
Phone: (021) 267-1939

CANADA

Erikson (A DIVISION OF JAM IN-
DUSTRIES LTD.) 378 Isabay Street, St.
Laurent, Quebec, Canada H4T 1W1
Phone: 514-738 3000

CHILE

Industrias Musicales Arriagada
Moneda 720 Of 110 EP, Santiago
Phone: 331819

COSTA RICA

Almacen J.M. Acuna V.
Apartado 926, San Jose

CYPRUS

Leon's Music Stores
P.O. Box 1440 Limassol
Phone: 051-73111, 051-66079

DENMARK

Hagstrom MUSIK EN GROS
Øresundsvej 148, DK-2300 København S
Phone: 01/554812

ECUADOR

Casa Musical Victor Freire
Aguirre No. 1 107 y Seis de Marzo Guaya-
quil, P.O. Box 6521
Phone: 522572

EGYPT

Abdallah George Youssef
P.O. Box 2904, El Horrieh, Heliopolis,
Cairo
Phone: 875618

EL SALVADOR

Almacenes Siman S.A. de C.V.
P.O. Box (06) 800, San Salvador
Phone: 22-0555

ENGLAND

Rose Morris & Co., Ltd.
32-34, Gordon House Road, London NWS
1NE
Phone: 01-267 5151

FINLAND

Kaukomarkkinat Oy
Kutojantie 4, SF-02630, ESPOO 63
Phone: 358-0-523711

FRANCE

Gaffarel Musique SA
12, Av., Alsace-Lorraine, Z. I. des
Béthunes, Saint-Ouen-1 'Aumône, 95310
Cergy
Phone: (3) 037 28 65

GREECE

Bon Studio
8 Zairi Str., Athens 10683
Phone: 3633 572

HONG KONG

Tom Lee Piano Co., Ltd.
9 Cameron Lane, Kowloon
Phone: 3-7221098

ICELAND

Tonkvisi
Laufasvegí 17, 101 Reykjavík
Phone: 25336

ITALY

CGD Messaggerie Musicali spa
via M.F. Quintilano, 40, 20138 Milano
Phone: 02/50841

ISRAEL

Sommerfeld Music Centre
8, Ben Yehuda Road, Tel-Aviv
Phone: 296775

JORDAN

Sonatina For Trade & Art Production
P.O. Box 3152, Jabal Amman, Amman
Phone: 44591

Twang Music Center

P.O. Box 35034, Amman
Phone: 44201

KOREA

White Tiger Enterprise Co.
81-2 Yunhi-Dong, Sudaemoon-ku, Seoul
Phone: 322-5557

KUWAIT

Technico Trading Co., Ltd.
P.O. Box 5032, KUWAIT, Arabian Gulf
Phone: 423917

LEBANON

Antoun's
Sadat St. Ras Beirut

MEXICO

Casa de Musica, S.A. de C.V.
Bolívar No. 75, cod Postal 06080 México,
D.F.
Phone: 512-73-37, 747-23-17

Casa Veerkamp, S.A.

Grandes Almacenes de Musica
Mesones 21 col Centro de La Ciudad
Deleg Cuauhtemoc 06080 México D.F.
Phone: (91-5) 585-33-11

Casa Wagner de Guadalajara, S.A.

Corona 202, Guadala ara, Jal
Phone: 13-14-14

NEW ZEALAND

Custom Music Limited
P.O. Box 4331, (16B ST MARKS RD.
NEWMARKET) Auckland 1
Phone: 500-272, 500-535

NORWAY

Hagstrom Musikk A/S
Nadderudvn 63, 1347 Hosle
Phone: 248090

PANAMA

Compania Alfaro, S.A.
Apartado 200, Panama 1
Phone: 23 0292

PARAGUAY

Music Hall SAIC
Paima 567, Asuncion

PHILIPPINES

Trebel Industries Inc.
251-267, J & L Building Edsa, Mandaluyong,
Metro Manila
Phone: 78-20-36

G.A. Yupangco & Co., Inc.
339 Buendia Av. Extension Makati, Metro
Manila
Phone: 85-97-26

POLAND

Centrala Handlowa Przemyslu Muzycz-
nego
ul. Długa 5, 00-263 Warszawa
Phone: 31-15-73, 31-32-31

R.O.C

Hai Kuo Musical Instrument Co., Ltd.
2nd Fl., No. 23, Sec. 1, Chung Hsiao-West
Road, Taipei, Taiwan
Phone: 02-314-3113

REP. OF SOUTH AFRICA

Hohner (South Africa) (PTY) LTD.
2nd Floor, Mayveen House, 160 President
Street, (cor. Nugget Street) 2001 Johan-
nesburg
Phone: 402-3726

SINGAPORE

City Music Co., Ptd., Ltd.
1 Sophia Road, #02-12/13 Peace Centre,
Singapore 0922
Phone: 337 7058, 337 7545, 337 3549

Yamaha Music (Asia) Pte., Ltd.

80 Tannery Lane, Singapore 1334
Phone: 747 4374

SPAIN

Letusa S.A.
Las Fraguas s/n, Apartado de Correos 125,
Alcorcon (Madrid)
Phone: 612 3376

SWEDEN

MUSITECH AB
Malmbergsgatan 4, S-211 38 Malmö
Phone: 040 706 25

SWITZERLAND

Musik-Meyer AG
Spitalstr. 74, 8952 Schlieren
Phone: 01 730 55 05

SYRIA

Meka Music House
MGRDITCH KAZANJIAN
P.O. Box No. 340, Shouhada St. Azizieh
Aleppo
Phone: 20861

Sarkis Kalaydjian

102 Maternite St. (Meydan), Aleppo
Phone: 43357

THAILAND

Beh Ngiep Seng Ltd., Part.
No. 110 Nakorn Kasem Soi 1 Bangkok
Phone: 222-5281

THE NETHERLANDS

Milestone B.V.
Gildenweg 16, Zwijndrecht, P.O. Box 207
Phone: (078) 10 0044

U.A.E.

Abdulla Sultan Al-Sharhan
P.O. Box 1675, Deira-Dubai
Phone: 221509

U.S.A.

Unicord
89 Frost St., Westbury, New York 11590
Phone: 516-333-9100

URUGUAY

Man/Pizzo Internacional
Casilla de Correo 6243, Montevideo

WEST GERMANY

Musik-Meyer GmbH
Postfach 1729, 3550 Marburg/Lahn
Phone: 06421/81051

KORG[®]

KEIO ELECTRONIC LABORATORY CORPORATION
15-12, Shimotakaido 1-chome, Suginami-ku, Tokyo, Japan.

©KEIO ELECTRONIC LABORATORY CORP. 1985

6002GTH PRINTED IN JAPAN

DW-6000

PRELOAD PROGRAM LIST

PROG NO.	PROGRAM NAME	OSC 1			OSC 2					NOISE	VCF					CHORUS	VCF EG						VCA EG					MG				BEND		PORTAMENTO TIME	ASSIGN MODE	
		OCTAVE	WAVEFORM	LEVEL	OCTAVE	WAVEFORM	LEVEL	INTERVAL	DETUNE		LEVEL	CUTOFF	RESONANCE	KBD TRACK	POLARITY		EG INT	ON/OFF	ATTACK	DECAY	BREAK P.	SLOPE	SUSTAIN	RELEASE	ATTACK	DECAY	BREAK P.	SLOPE	SUSTAIN	RELEASE	FREQ	DELAY	OSC			VCF
		11	12	13	21	22	23	24	25	26	31	32	33	34	35	36	41	42	43	44	45	46	51	52	53	54	55	56	61	62	63	64	71	72	73	
11	SYNTH BRASS	16	1	31	16	1	31	1	5	3	6	0	1	1	27	1	3	20	18	20	27	11	0	31	31	28	28	9	8	11	0	0	2	0	0	POLY 1
12	BELLS 1	4	8	31	16	8	31	5	5	0	3	0	2	1	25	1	0	24	22	25	0	26	0	31	26	26	29	31	0	0	0	0	2	0	0	POLY 1
13	ACOUSTIC PIANO	16	3	31	16	8	19	1	4	0	38	5	1	1	6	0	0	13	13	17	0	12	0	19	21	21	0	9	8	0	0	0	2	0	0	POLY 1
14	BOWED CELLOS	16	1	31	16	6	21	1	5	0	31	1	2	1	5	1	0	16	0	0	0	13	10	16	19	12	18	10	8	0	3	0	2	0	0	POLY 1
15	DYNO PIANO	16	4	24	16	4	23	1	2	0	14	0	1	1	18	1	0	21	24	24	0	18	0	31	31	31	0	7	8	11	0	0	2	0	0	POLY 1
16	PERCUS SYNTH 1	16	1	31	16	1	31	1	5	0	26	4	1	1	25	1	0	12	8	24	12	3	0	31	31	31	31	7	8	11	2	0	2	0	0	POLY 1
17	PAN FLUTE	8	2	11	8	8	13	1	3	0	15	0	1	1	20	1	0	6	16	19	16	9	4	23	31	31	31	9	7	0	0	2	2	0	0	POLY 1
18	ORGAN CHIFF	8	8	12	16	4	31	1	3	0	25	0	1	1	21	1	1	10	17	21	13	17	8	31	31	31	31	8	8	0	0	0	2	0	0	POLY 1

PROG NO.	PROGRAM NAME	OSC 1			OSC 2					NOISE	VCF					CHORUS	VCF EG						VCA EG						MG				BEND		PORTAMENTO TIME	ASSIGN MODE		
		OCTAVE	WAVEFORM	LEVEL	OCTAVE	WAVEFORM	LEVEL	INTERVAL	DETUNE		LEVEL	CUTOFF	RESONANCE	KBD TRACK	POLARITY		EG INT	ON/OFF	ATTACK	DECAY	BREAK P.	SLOPE	SUSTAIN	RELEASE	ATTACK	DECAY	BREAK P.	SLOPE	SUSTAIN	RELEASE	FREQ	DELAY	OSC	VCF			OSC	VCF ON/OFF
		11	12	13	21	22	23	24	25	26	31	32	33	34	35	36	41	42	43	44	45	46	51	52	53	54	55	56	61	62	63	64	71	72	73			
21	MARIMBA	16	8	31	16	2	19	1	2	3	11	0	0	1	22	1	0	9	20	19	0	13	0	31	31	31	0	11	8	0	0	0	2	0	0	POLY 1		
22	DIGI SOUND 1	16	5	25	16	5	25	1	3	3	0	0	2	1	31	1	0	19	0	0	0	15	0	18	0	0	0	15	8	0	0	0	2	0	0	POLY 1		
23	LOW STRINGS	16	1	31	16	1	31	1	5	0	38	1	2	1	0	1	0	0	0	0	0	19	17	31	31	28	23	15	8	0	3	0	2	0	0	POLY 1		
24	VIBES 1	4	8	31	16	8	19	1	0	3	28	0	2	1	6	1	0	9	18	26	0	13	0	31	31	21	28	17	6	0	1	3	2	0	0	POLY 1		
25	BREAK DANCE	16	6	0	16	3	0	1	2	0	18	30	2	1	12	1	0	8	11	8	15	31	0	8	0	15	0	0	8	0	0	0	0	1	0	0	POLY 1	
26	ORGAN with PERCUS	16	2	31	16	2	23	1	0	0	29	24	2	1	0	1	0	9	0	0	0	0	0	0	31	0	31	0	8	0	0	0	2	0	0	0	POLY 1	
27	LEAD SYNTH	16	3	29	16	1	31	1	6	0	0	0	0	1	28	1	0	30	23	26	0	27	0	31	31	27	31	19	8	19	5	0	2	0	18	UNI SON		
28	AFRICA	16	5	25	16	2	25	1	4	3	15	0	1	1	14	1	4	16	19	22	12	11	3	31	31	31	31	10	8	0	0	0	2	0	0	0	POLY 1	
31	JET PLANE	8	8	0	16	4	0	1	3	31	18	0	0	1	15	1	28	24	13	26	27	28	3	31	31	31	31	26	0	0	0	0	0	1	0	0	UNI SON	
32	SAXS	16	6	31	16	6	31	1	4	0	26	1	1	1	12	1	3	18	24	13	22	11	2	0	22	14	24	8	31	0	0	2	2	0	0	0	POLY 2	
33	ACOUSTIC GUITAR	16	5	31	16	5	31	1	1	0	9	3	1	1	15	0	0	17	23	22	0	13	0	31	31	27	0	3	11	0	0	0	2	0	0	0	0	POLY 1
34	CELESTE	4	8	31	4	8	31	1	2	0	52	12	2	1	0	0	0	9	0	0	0	21	0	16	0	0	0	16	8	0	0	0	2	0	0	0	0	POLY 1
35	FLUTE CHORUS	8	2	31	8	1	31	1	2	5	19	2	2	1	9	1	8	11	18	14	18	16	4	31	31	31	31	5	6	15	0	3	2	0	0	0	0	POLY 1
36	SYN DRUM	16	6	0	16	3	0	1	2	31	7	30	2	1	8	1	0	16	0	8	0	31	0	19	31	15	0	7	8	0	0	0	0	1	0	0	0	UNI SON

PROG NO.	PROGRAM NAME	OSCS1 C			OSC 2					NOISE	VCF					CHORUS	VCF EG					VCA EG					MG				BEND		PORTAMENTO TIME	ASSIGN MODE			
		OCTAVE	WAVEFORM	LEVEL	OCTAVE	WAVEFORM	LEVEL	INTERVAL	DETUNE		LEVEL	CUTOFF	RESONANCE	KBD TRACK	POLARITY		EG INT	ON/OFF	ATTACK	DECAY	BREAK P.	SLOPE	SUSTAIN	RELEASE	ATTACK	DECAY	BREAK P.	SLOPE	SUSTAIN	RELEASE	FREQ	DELAY			OSC	VCF	OSC
		11	12	13	21	22	23	24	25	26	31	32	33	34	35	36	41	42	43	44	45	46	51	52	53	54	55	56	61	62	63	64	71	72	73		
37	PIPE ORGAN	16	4	31	8	8	28	5	4	0	40	0	2	1	0	1	0	9	0	0	0	0	3	0	31	0	31	12	8	0	0	0	2	0	0	POLY 1	
38	HELICOPTER	16	8	31	16	4	31	1	3	31	0	0	0	1	13	1	28	29	10	28	23	28	9	31	31	31	31	26	19	0	0	31	2	1	0	POLY 1	
41	CHOIR	8	2	27	8	2	31	1	4	3	30	25	2	1	1	1	0	20	20	21	20	15	22	31	31	31	0	14	7	0	7	0	2	0	0	POLY 1	
42	SYNTH BASS 1	16	6	31	16	1	31	1	0	0	0	19	2	1	24	1	0	17	21	22	0	0	0	31	31	31	31	0	8	0	0	0	2	0	0	UNI SON	
43	HIGH STRINGS	8	2	22	8	2	18	1	4	3	45	1	2	1	6	1	0	8	0	3	15	12	11	31	31	31	31	12	9	0	4	0	2	0	0	POLY 1	
44	TRUMPETS	8	1	31	8	5	0	1	1	0	12	0	1	1	31	1	3	10	24	31	20	6	0	31	31	31	31	5	8	17	7	0	2	0	0	POLY 1	
45	HARPSICHORD	4	7	26	8	7	31	1	2	0	56	2	1	1	6	1	0	9	12	19	0	17	0	15	15	19	0	9	8	7	0	0	2	0	0	POLY 1	
46	ELECTRONIC ORGAN	16	4	31	4	5	15	5	2	0	30	0	1	1	8	1	0	9	0	0	0	0	0	0	0	31	0	31	0	8	0	0	1	2	0	0	POLY 1
47	DIGI BASS	16	5	31	16	5	31	1	1	0	9	3	1	1	15	0	0	17	23	22	0	13	0	31	31	27	0	3	11	0	0	0	2	0	0	UNI SON	
48	SONG WHISTLE	16	8	0	16	4	0	1	3	0	26	31	2	1	3	1	12	31	31	31	31	10	9	31	31	31	31	3	4	0	0	0	0	1	0	POLY 1	
51	PERCUS SYNTH 2	16	1	31	16	6	31	1	0	0	17	11	2	1	22	1	0	12	15	14	0	19	0	31	31	31	0	5	8	0	0	0	2	0	0	POLY 1	
52	BELLS 2	16	3	29	16	8	26	5	4	0	14	0	0	1	20	1	0	18	23	18	0	18	0	0	31	0	31	19	8	19	5	0	2	0	0	POLY 1	
53	HONKEY PIANO	8	6	31	8	3	31	1	6	0	32	0	1	1	8	1	0	16	17	13	14	31	0	21	21	20	0	8	8	0	0	0	2	0	0	POLY 1	
54	B. JEAN	16	2	25	16	1	28	1	5	0	0	0	2	1	20	1	4	24	31	26	16	22	0	31	14	26	31	8	8	11	4	0	2	0	0	POLY 1	

PROG NO.	PROGRAM NAME	OSC 1			OSC 2					NOISE	VCF					CHORUS	VCF EG						VCA EG					MG				BEND		PORTAMENTO TIME	ASSIGN MODE	
		OCTAVE	WAVEFORM	LEVEL	OCTAVE	WAVEFORM	LEVEL	INTERVAL	DETUNE	LEVEL	CUTOFF	RESONANCE	KBD TRACK	POLARITY	EG INT	ON/OFF	ATTACK	DECAY	BREAK P.	SLOPE	SUSTAIN	RELEASE	ATTACK	DECAY	BREAK P.	SLOPE	SUSTAIE	RELEASE	FREQ	DELAY	OSC	VCF	OSC			VCF ON/OFF
		11	12	13	21	22	23	24	25	26	31	32	33	34	35	36	41	42	43	44	45	46	51	52	53	54	55	56	61	62	63	64	71			72
55	POLY GLIDE	16	1	31	16	5	31	1	4	2	24	1	0	1	31	1	0	14	14	0	29	31	0	31	31	31	31	23	8	13	0	0	2	0	20	POLY 2
56	HARP	8	3	28	8	2	18	1	3	0	26	5	1	1	10	0	0	9	18	14	0	18	0	31	30	15	0	14	8	0	0	0	2	0	0	POLY 1
57	BOWED VIOLINS	16	4	10	16	2	31	1	5	3	23	1	2	1	23	1	0	11	19	10	13	14	8	23	11	31	14	8	8	0	5	0	2	0	0	POLY 1
58	WIND STORM	8	8	0	16	4	0	1	3	31	36	22	1	1	0	0	23	10	17	21	13	17	29	31	31	31	31	22	0	0	0	5	0	1	0	UNI SON
61	THUNDER	4	8	0	16	8	0	1	0	18	10	0	1	1	16	1	0	31	31	26	18	20	0	30	27	26	28	31	31	0	15	0	0	1	0	POLY 1
62	DIGI SOUND 2	16	5	13	16	5	20	1	3	0	0	0	0	1	31	1	0	31	22	21	16	22	0	1	0	0	31	11	8	11	0	0	2	0	0	POLY 1
63	UPRIGHT PIANO	8	6	31	8	3	31	1	2	0	32	0	1	1	8	0	0	16	17	13	14	31	0	21	21	20	0	8	8	0	0	0	2	0	0	POLY 1
64	ELECTRIC PIANO	16	2	31	16	2	31	1	2	0	44	0	1	1	2	1	0	23	15	0	15	31	0	17	15	22	0	8	8	0	0	0	2	0	0	POLY 1
65	SYNTH PAD	16	2	15	16	1	31	1	5	3	45	0	2	1	0	1	0	20	25	18	24	15	0	31	31	31	0	9	8	0	2	0	2	0	0	POLY 1
66	TROMBONE	16	1	31	16	1	0	1	3	0	10	0	1	1	19	1	6	17	15	20	18	8	0	31	28	28	0	7	31	0	2	1	2	0	0	POLY 1
67	ELECTRONIC ORGAN UM	4	2	31	16	1	31	1	3	0	36	0	2	1	2	1	0	10	0	31	31	19	0	31	31	31	31	0	8	0	0	0	2	0	0	POLY 1
68	TOUCH SENSE SWEEP	16	2	31	16	1	31	1	4	0	44	27	0	2	13	1	0	9	31	10	0	22	0	21	23	25	12	25	8	0	6	0	2	0	0	POLY 1
71	MONSTERS	16	8	0	16	4	0	1	3	0	11	31	2	1	6	1	21	21	16	31	31	25	9	31	31	31	31	22	31	0	0	19	0	1	0	POLY 1
72	ACCORDION	4	1	31	8	2	31	1	0	0	63	0	2	1	31	1	0	15	22	17	12	26	4	27	19	14	15	5	31	0	5	0	2	0	0	POLY 1

PROG NO.	PROGRAM NAME	OSC 1			OSC 2					NOISE LEVEL	VCF					CHORUS ON/OFF	VCF EG						VCA EG					MG				BEND		PORTAMENTO TIME	ASSIGN MODE	
		OCTAVE	WAVEFORM	LEVEL	OCTAVE	WAVEFORM	LEVEL	INTERVAL	DETUNE		CUTOFF	RESONANCE	KBD TRACK	POLARITY	EG INT		ATTACK	DECAY	BREAK P.	SLOPE	SUSTAIN	RELEASE	ATTACK	DECAY	BREAK P.	SLOPE	SUSTAIN	RELEASE	FREQ	DELAY	OSC	VCF	OSC			VCF ON/OFF
		11	12	13	21	22	23	24	25	26	31	32	33	34	35	36	41	42	43	44	45	46	51	52	53	54	55	56	61	62	63	64	71	72	73	
73	D. TONGUING BRASS	16	1	31	16	1	31	1	1	0	9	0	2	1	31	1	0	7	0	0	31	8	0	31	31	31	9	8	0	4	0	2	0	0	POLY 1	
74	VIBES 2	16	8	31	16	5	0	1	1	0	13	0	1	1	20	1	0	11	25	19	0	25	0	31	31	31	0	23	6	0	0	2	2	0	0	POLY 1
75	SYNTH SWEEP	16	1	31	16	1	31	1	4	0	0	26	0	1	31	1	0	28	0	0	0	21	0	23	31	0	31	24	8	0	0	0	2	0	0	POLY 1
76	STEEL DRUMS	16	3	14	8	5	19	5	6	0	12	0	1	1	20	1	0	13	23	17	0	15	0	31	31	31	0	20	8	0	0	0	2	0	0	POLY 1
77	TUBULER BELLS	8	8	31	16	8	18	5	1	0	0	0	0	1	26	1	0	23	18	22	0	20	0	31	26	26	29	31	0	0	0	0	2	0	0	POLY 1
78	ELECTRONIC PIANO 2	16	2	31	16	2	0	1	1	0	7	2	0	1	22	1	0	15	15	19	0	10	0	22	31	23	0	5	8	0	0	0	2	0	0	POLY 1
81	SYNTH BASS 2	16	1	31	16	1	31	1	4	1	10	4	0	1	20	1	0	15	29	9	27	9	0	21	14	17	0	14	8	0	0	0	2	0	0	UNI SON
82	OLD E. PIANO	8	2	17	16	4	31	1	4	0	14	4	1	1	14	1	0	13	26	21	0	11	0	9	27	23	0	8	3	0	2	2	2	0	0	POLY 1
83	BRASS IN 5th	8	1	31	8	1	31	5	0	0	9	1	1	1	29	1	5	10	24	31	20	6	0	31	31	31	31	5	8	17	7	0	2	0	0	POLY 1
84	DIGI HORNS	16	4	31	16	1	22	1	0	0	6	4	1	1	23	1	10	14	14	24	24	11	0	31	31	31	31	7	8	0	4	0	2	0	0	POLY 1
85	PERCUS SYNTH 3	16	3	31	8	4	25	5	0	3	13	17	2	1	20	1	0	13	23	18	0	7	0	31	31	31	31	8	10	0	0	0	2	0	0	POLY 1
86	TOUCH SENSE VIBES	16	8	24	16	8	0	1	3	3	12	9	2	1	11	1	0	12	17	8	0	22	0	12	21	24	28	20	4	0	1	5	2	0	0	POLY 1
87	NOISE DROPS	16	3	0	8	8	0	1	0	31	36	28	2	2	0	0	31	31	31	16	0	4	0	24	13	15	12	8	10	11	0	0	0	1	0	POLY 1
88	REVERSE SWEEP	16	2	31	16	5	31	1	4	0	53	28	2	2	14	1	19	26	15	19	0	18	0	21	23	25	12	14	8	0	0	0	2	0	0	POLY 1

