

DENON

Hi-Fi Component

SERVICE MANUAL

MODEL DCD-1290
MODEL DCD-2060
MODEL DCD-2060G
STEREO CD PLAYER

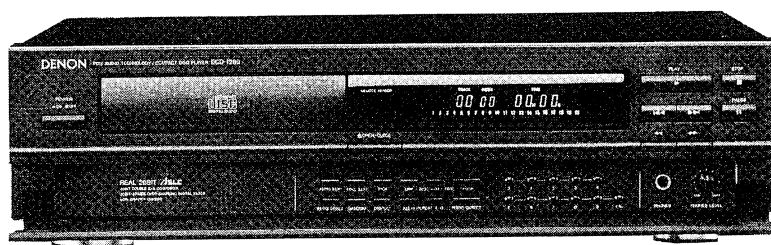

(Photo: DCD-1290)

— TABLE OF CONTENTS —

OPERATING INSTRUCTIONS	2 ~ 8
SPECIFICATIONS	9
NOTE FOR HANDLING OF LASER PICK-UP	10, 11
DISASSEMBLY	12
ADJUSTMENT	13 ~ 17
HEAT RUN MODE FUNCTION	18
IC TERMINAL FUNCTION	19 ~ 22
PARTS LIST OF P.W.BOARD	23 ~ 26
PARTS LIST OF PACKING & ACCESSORIES	26
PARTS LIST OF FG-50 MECHANISM UNIT	27
EXPLODED VIEW OF FG-50 MECHANISM UNIT	27
PARTS LIST OF EXPLODED VIEW (DCD-1290/2060)	28
EXPLODED VIEW (DCD-1290/2060)	29
EXPLODED VIEW (DCD-2060G)	30
PARTS LIST OF EXPLODED VIEW (DCD-2060G)	31
P.W.BOARD	32 ~ 34
SEMICONDUCTORS	35
WIRING DIAGRAM	36
SCHEMATIC DIAGRAM	37, 38

NIPPON COLUMBIA CO., LTD.

IMPORTANT TO SAFETY

WARNING:

TO PREVENT FIRE OR SHOCK HAZARD, DO NOT EXPOSE THIS APPLIANCE TO RAIN OR MOISTURE.

CAUTION:

1. Handle the power supply cord carefully
Do not damage or deform the power supply cord. If it is damaged or deformed, it may cause electric shock or malfunction when used. When removing from wall outlet, be sure to remove by holding the plug attachment and not by pulling the cord.
2. Do not open the top cover
In order to prevent electric shock, do not open the top cover. If problems occur, contact your DENON DEALER.
3. Do not place anything inside
Do not place metal objects or spill liquid inside the CD player. Electric shock or malfunction may result.

Please, record and retain the Model name and serial number of your set shown on the rating label.
Model No. DCD-1290/2060/2060G Serial No. _____

CAUTION
RISK OF ELECTRIC SHOCK
DO NOT OPEN

CAUTION: TO REDUCE THE RISK OF ELECTRIC SHOCK, DO NOT REMOVE COVER (OR BACK). NO USER SERVICEABLE PARTS INSIDE. REFER SERVICING TO QUALIFIED SERVICE PERSONNEL.

The lightning flash with arrowhead symbol within an equilateral triangle is intended to alert the user of the presence of uninsulated "dangerous voltage" within the product's enclosure that may be of sufficient magnitude to constitute a risk of electric shock to persons.

The exclamation point within an equilateral triangle is intended to alert the user of the presence of important operating and maintenance (servicing) instruction in the literature accompanying the appliance.

CLASS 1 LASER PRODUCT
LUOKAN 1 LASERLAITE
KLASS 1 LASERAPPARAT

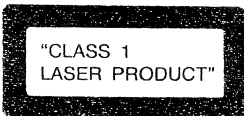

CLASS 1 LASER PRODUCT
LUOKAN 1 LASERLAITE
KLASS 1 LASERAPPARAT

ADVARSEL: USYNLIG LASERSTRÅLING VED ÅBNING UDGÅ UDSÆTTELSE FOR STRÅLING.
VAROITUS: LAITTEEN KÄYTTÄMINEN MUULLA KUIN TÄSSÄ KÄYTTÖOHJEESSA MAINITTULLA TAVALLA SÄÄTTÄÄ ALITSTAA KÄYTTÄJÄN TURVALLISUUSLUOKAN 1 YLITÄVÄLLE NÄKYMÄTTÖMÄLLE LASERSÄTEILYLLE.
BRUKSANVISNING SPECIFICERATS, KAN ANVÄNDAREN UTSÄTTAS FÖR ÖSNLIG LASERSTRÅLNING, SOM ÖVERSKRIDER GRÄNSEN FÖR LASERKLASS 1.



NOTE:

This CD player uses the semiconductor laser. To allow you to enjoy music at a stable operation, it is recommended to use this in a room of 5°C (41°F) - 35°C (95°F).

LABELS (for U.S.A. model only)

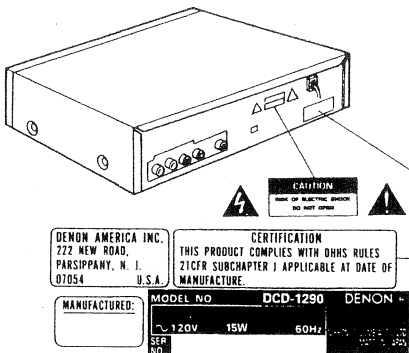

CAUTION:

USE OF CONTROLS OR ADJUSTMENTS OR REPERFORMANCE OF PROCEDURES OTHER THAN THOSE SPECIFIED HEREIN MAY RESULT IN HAZARDOUS RADIATION EXPOSURE.

THE COMPACT DISC PLAYER SHOULD NOT BE ADJUSTED OR REPAIRED BY ANYONE EXCEPT PROPERLY QUALIFIED SERVICE PERSONNEL.

NOTE:

This unit may cause interference to radio and television reception if you do not operate it in strict accordance with this OPERATING INSTRUCTIONS.

This unit complies with Class B computing device rules in accordance with the specifications in Sub-part J or Part 15 of the FCC Rules, which are designed to provide reasonable protection against such interference in a residential installation. If the unit does cause interference to any radio or television reception, try to reduce it by one or more of the following means:

- a) Turn the other unit to improve reception
- b) Move this unit
- c) Move this unit away from others
- d) Plug this unit respectively into a different AC outlet

* This is note in accordance with Section 15.838 of the FCC Rules.

IMPORTANT (BRITISH MODEL ONLY)

The wires in this mains lead are coloured in accordance with the following code:

Blue: Neutral Brown: Live

The colours of the wires in the mains lead of this apparatus may not correspond with the coloured markings identifying the terminals in your plug proceed as follows:
The wire which is coloured blue must be connected to the terminal which is marked with the letter N or coloured black.





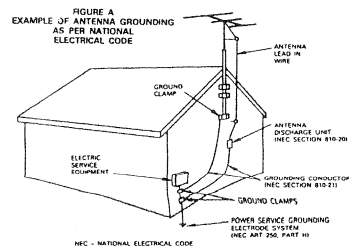

The wire which is coloured brown must be connected to the terminal which is marked with the letter L or coloured red.

SAFETY INSTRUCTIONS

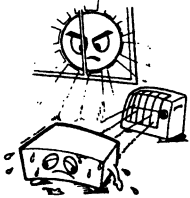
1. Read Instructions - All the safety and operating instructions should be read before the appliance is operated.
2. Retain Instructions - The safety and operating instructions should be retained for future reference.
3. Heed Warnings - All warnings on the appliance and in the operating instructions should be adhered to.
4. Follow Instructions - All operating and use instructions should be followed.
5. Water and Moisture - The appliance should not be used near water - for example, near a bathtub, washbowl, kitchen sink, laundry tub, in a wet basement, or near a swimming pool, and the like.
6. Carts and Stands - The appliance should be used only with a cart or stand that is recommended by the manufacturer.
- 6A. An appliance and cart combination should be moved with care. Quick stops, excessive force, and uneven surfaces may cause the appliance and cart combination to overturn.
7. Wall or Ceiling Mounting - The appliance should be mounted to a wall or ceiling only as recommended by the manufacturer.
8. Ventilation - The appliance should be situated so that its location or position does not interfere with its proper ventilation. For example, the appliance should not be situated on a bed, sofa, rug, or similar surface that may block the ventilation openings; or, placed in a built-in installation, such as a bookcase or cabinet that may impede the flow of air through the ventilation openings.
9. Heat - The appliance should be situated away from heat sources such as radiators, heat registers, stoves, or other appliances (including amplifiers) that produce heat.
10. Power Sources - The appliance should be connected to a power supply only of the type described in the operating instructions or as marked on the appliance.
11. Grounding or Polarization - Precautions should be taken so that the grounding or polarization means of an appliance is not defeated.
12. Power-Cord Protection - Power-supply cords should be routed so that they are not likely to be walked on or pinched by items placed upon or against them, paying particular attention to cords at plugs, convenience receptacles, and the point where they exit from the appliance.
14. Cleaning - The appliance should be cleaned only as recommended by the manufacturer.
15. Power Lines - An outdoor antenna should be located away from power lines.
16. Outdoor Antenna Grounding - If an outside antenna is connected to the receiver, be sure the antenna system is grounded so as to provide some protection against voltage surges and built-up static charges. Article 810 of the National Electrical Code, ANSI/NFPA 70, provides information with regard to proper grounding of the mast and supporting structure, grounding of the lead-in wire to an antenna-discharge unit, size of grounding conductors, location of antenna-discharge unit, connection to grounding electrodes, and requirements for the grounding electrode. See Figure A.
17. Nonuse Periods - The power cord of the appliance should be unplugged from the outlet when left unused for a long period of time.
18. Object and Liquid Entry - Care should be taken so that objects do not fall and liquids are not spilled into the enclosure through openings.
19. Damage Requiring Service - The appliance should be serviced by qualified service personnel when:
 - A. The power-supply cord or the plug has been damaged; or
 - B. Objects have fallen, or liquid has been spilled into the appliance; or
 - C. The appliance has been exposed to rain; or
 - D. The appliance does not appear to operate normally or exhibits a marked change in performance; or
 - E. The appliance has been dropped, or the enclosure damaged.
20. Servicing - The user should not attempt to service the appliance beyond that described in the operating instructions. All other servicing should be referred to qualified service personnel.

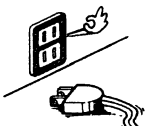
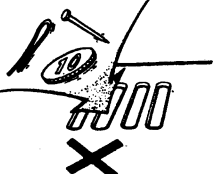
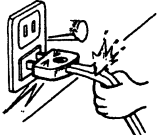

NOTE ON USE

 <p>Be careful of high temperatures</p> <ul style="list-style-type: none"> Do not place the set in a location where it will be exposed to direct sunlight or near a heating appliance. <p>Caution on rack/cabinet installation</p> <ul style="list-style-type: none"> Avoid installing the set in a closed-type rack. When installing in a rack or cabinet, provide a sufficiently large ventilation opening to promote heat radiation. 	 <p>Caution on humidity, water, and dust</p> <ul style="list-style-type: none"> Do not place the set in a location where there is high humidity or a lot of dust. <p>Flower vases or other items containing water should not be placed on top of the set.</p>	 <p>Do not open the case</p> <ul style="list-style-type: none"> Opening the top cover or the bottom plate of the case and inserting your hand is dangerous. Do not open the case. <p>If some trouble arises with the performance of the set, remove the power plug soon and contact the store where the set was purchased or a nearby dealer.</p>
<p>Do not allow foreign matter into the equipment</p> <ul style="list-style-type: none"> Be especially careful of needles, hair pins, and coins getting into the set. 	 <p>Care of the case</p> <ul style="list-style-type: none"> Avoid the use of pesticides near the set as well as wiping the case with benzine, thinner or other solvents since they may cause a change in quality or color. Use a soft cloth when wiping away dirt and follow the instructions carefully when using chemically treated cloths. 	 <p>During your absence</p> <ul style="list-style-type: none"> When not using the set for an extended period such as when taking a trip, be sure to disconnect the plug from the receptacle.
	 <p>Care with the power cord</p> <ul style="list-style-type: none"> When removing the plug from the receptacle, do not pull the power cord; be sure to hold the plug when removing it. 	 <p>For sets with ventilation holes</p> <p>Do not block the ventilation holes of the set</p> <ul style="list-style-type: none"> Blocking of the ventilation holes will lead to damage of the set. The ventilation holes are very important for heat radiation from within the set. Care must be taken since placing an object against the holes will result in an extreme rise of temperature within the set.

Thank you for purchasing this DENON Compact Disc Player. Please read the operating instructions thoroughly in order to acquaint yourself with the CD player and achieve maximum satisfaction from it.

— TABLE OF CONTENTS —

FEATURES 5
 NAMES AND FUNCTIONS OF PARTS 6, 7
 CONNECTION 8
 OPENING AND CLOSING THE DISC HOLDER AND LOADING A DISC 8
 NORMAL CD PLAYBACK 8, 9
 ADVANCED CD PLAYBACK 9 ~ 13
 TIMER-CONTROLLED PLAYBACK 13
 THE COMPACT DISC 13
 PLAYBACK USING THE REMOTE CONTROL UNIT 14, 15
 INSTALLATION PRECAUTIONS 15
 TROUBLESHOOTING 15

Please check to make sure the following items are included with the main unit in the carton:

- (1) Operating Instructions 1
- (2) Connection Cord 1
- (3) Remote Control Unit RC-234 (for U.S.A., Asia, Australia model), RC-235 (British model) 1
- (4) R6P AA Dry Cell Battery 2

• Line Voltage Selection (for multiple voltage model only)

- The desired voltage may be set with the VOLTAGE SELECTOR knob on the rear panel, using a screwdriver.
- Do not twist the VOLTAGE SELECTOR knob with excessive force as this may cause damage.
- If the VOLTAGE SELECTOR knob does not turn smoothly, please contact a qualified serviceman.

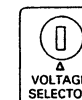

• FOR U.S.A. & CANADA MODEL ONLY

CAUTION

TO PREVENT ELECTRIC SHOCK DO NOT USE THIS (POLARIZED) PLUG WITH AN EXTENSION CORD, RECEPTACLE OR OTHER OUTLET UNLESS THE BLADES CAN BE FULLY INSERTED TO PREVENT BLADE EXPOSURE.

• POUR LES MODELES AMERICAINS ET CANADIENS UNIQUEMENT

ATTENTION

POUR PREVENIR LES CHOCS ELECTRIQUES NE PAS UTILISER CETTE FICHE POLARISEE AVEC UN PROLONGATEUR UNE PRISE DE COURANT OU UNE AUTRE SORTIE DE COURANT, SAUF SI LES LAMES PEUVENT ETRE INSEREES A FOND SANS EN LAISSER AUCUNE PARTIE A DECOUVERT.

FEATURES

The DCD-1290/2060/2060G is a CD player which uses DENON's unique A S.L.C. (Super Linear Converter) for eliminating loss of sound quality in the PCM playback section to offer playback of the same sounds as those in the studio or hall where the CD was recorded. In addition, the use of carefully selected parts makes this a high performance CD player reproducing the original sound field with rich musical expression.

(1) Real 20-bit A.S.L.C. (Super Linear Converter)

The use of DENON's unique system for preventing zero cross distortion, the main factor in loss of sound quality in the PCM playback section, plus real 20-bit D/A converters with superior resolution, offers reproduction of the original sound field with rich musical expression.

(2) High performance digital filter

The independent real 20-bit D/A converters for the left and right channels and a high precision digital filter with 8 times oversampling bring out the best of the analog filter to produce crisp, clear sound.

(3) Remote control unit with volume control

In addition to such functions as play, pause, stop and direct search using number buttons, the remote control unit also includes + and - volume buttons for remote control of the volume. The remote control functions greatly add to the operability of the set.

(4) Digital Output (OPTICAL/COAXIAL)

The data on the compact disc is output in digital format, so the music can be reproduced on an external digital processor or D/A unit.

(5) Playback of 8-centimeter CD singles

8-centimeter CD singles can be played on the DCD-1290/2060/2060G without an adapter.

NAMES AND FUNCTIONS OF PARTS

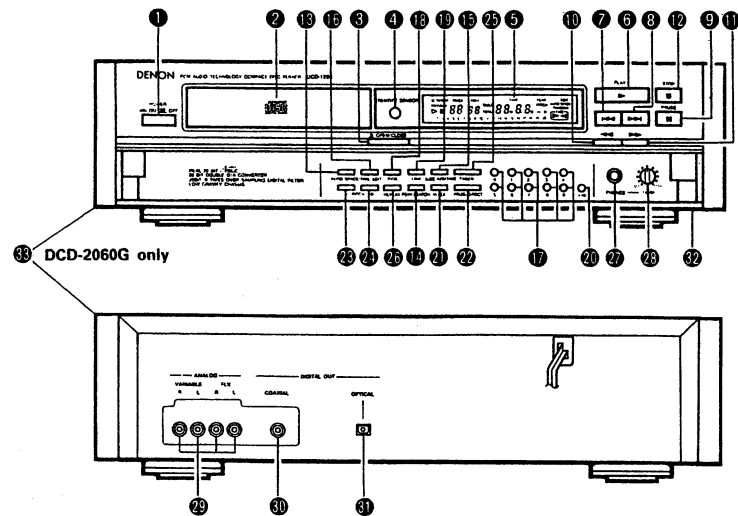

1 Power Switch (POWER)

- When the power is turned on, "[- 2 0]" appears on the TIME display, and if no disc is loaded, "[00000000]" appears on the digital display.
- If the power is turned on with a disc already loaded, the total number of tracks on the disc is displayed on the TRACK NO. display, the total time is displayed on the TIME display, the numbers on the music calendar light up to the number of tracks on the disc, and playback begins.
- When the power is turned off, the unit is set to the standby mode.

2 Disc Holder

- Place the disc on the disc holder with the label facing up.
- Use the open/close button (▲ OPEN/CLOSE) 3 to open and close the disc holder.
- The disc holder may also be closed by pressing the play button (▶ PLAY) 6 or pause button (|| PAUSE) 9.

3 Open/Close Button (▲ OPEN/CLOSE)

- The disc holder is opened and closed by pressing this button.
- Press this button once to open the disc holder, and once again to close it.
- When the disc holder is closed with a disc loaded, the disc will rotate for a couple of seconds while the disc contents are read. The number of tracks and total playback time on the disc are then displayed on the digital display 5.

4 Remote Control Sensor (REMOTE SENSOR)

- This sensor receives the infrared light transmitted from the wireless remote control unit.
- For remote control, point the supplied remote control unit RC-234/235 towards this sensor.
- When a signal is transmitted from the remote control unit, the remote control indicator in the display 5 will light up briefly.

5 Display

- The digital display is divided into sections, such as displays for track number, index, playback time and calendar, as shown below.

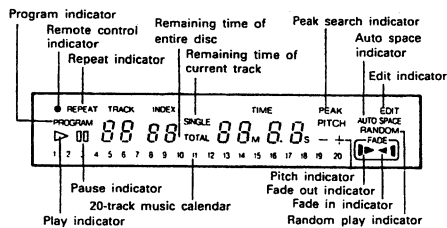

6 Play Button (▶ PLAY)

- Press this button to start playback of a disc.
- When this button is pressed, [] is displayed, and the track number being played is displayed together with the elapsed playback time of the track.
- Tracks are shown on the calendar display. Once a track has been played, the corresponding track number goes out on the calendar display.

7 Automatic Search Reverse Button (◀◀)

- Press this button to return the pickup to the beginning of the present track. Press again to return to other tracks.
- By pressing the button a number of times, the pickup will move back the corresponding number of tracks.

8 Automatic Search Forward Button (▶▶)

- Press this button to move the pickup forward to the beginning of the next track. Press again to move ahead to other tracks.
- By pressing the button a number of times, the pickup will advance the corresponding number of tracks.

9 Pause Button (|| PAUSE)

- Press this button to stop playback temporarily.
- If this button is pressed during playback, playback is stopped temporarily, the [] indicator goes out and the [] indicator lights.
- Press this button or the play button (▶ PLAY) again to continue playback.

10 Manual Search Reverse Button (◀◀)

- Press this button during playback for fast reverse search. As long as the button is kept pressed, music signals are played back faster than normal.
- Pressing this button when the pause mode is engaged, you can quickly reverse the pickup to a desired position, three times faster compared to manual reverse search during playback. During this time, no sound is heard.

11 Manual Search Forward Button (▶▶)

- Press this button during playback for fast forward search. As long as the button is kept pressed, music signals are played back faster than normal.
- Pressing this button when the pause mode is engaged, you can quickly forward the pickup to a desired position, three times faster compared to manual forward search during playback. During this time, no sound is heard.

12 Stop Button (■ STOP)

- Press this button to stop playback.
- The disc will stop rotating, and the number of tracks and total playing time of the disc are displayed on the TRACK NO. and TIME displays, respectively.
- In case programmed playback is engaged when this button is pressed, the number of tracks and total playing time of the program are displayed.

13 Auto Space Button (AUTO SPACE)

- Pressing this button will cause the [AUTO SPACE] indicator to light and a blank space of approximately 4 seconds is inserted between tracks during CD playback. Pressing the button once more, the [AUTO SPACE] indicator goes out and the Auto Space feature is cancelled.
- When one of the track search buttons (◀◀ or ▶▶) is pressed, the Auto Space function will not operate.
- The Auto Space function will work during normal playback as well as programmed playback.
- Although 4-second blanks are inserted between tracks, this additional time is not reflected by the indication on the time remaining display or time display when the Auto Edit function is engaged.

14 Peak Search Button (PEAK SEARCH)

- Press this button to search for the peak level. (Refer to Page 12, 13)

15 Side A/B and Time Mode Button (SIDE A/B/TIME)

- Press this button to switch between the display of side A and side B of the tape during the time edit operation. (Only when stopped.)
- This button is used to select the desired indication on the TIME display. The indication on this display will change each time the button is pressed. Normally, the elapsed playback time of the current track is displayed. Pressing the button once, [SINGLE] is displayed and the remaining time of the current track is displayed. Pressing once more, [TOTAL] is displayed, and total playing time of remaining tracks is displayed. However, when programmed play is in progress, the total remaining time of the program is displayed. Pressing the button once again to return to the normal display of the elapsed playback time of the current track.

16 Time Edit Button (TIME EDIT)

- Press this button to edit in conjunction with the tape time. (Refer to Page 11.)

17 Number Buttons (0, 1, 2, 3, 4, 5, 6, 7, 8, and 9)

- Use these buttons for the direct search and program memory functions.
- For direct search, press for example button [3] if you want to hear track number 3. For track number 12, press [+10] then [2]. To program tracks, press the PROG/DIRECT button 22 to set to the program mode.

18 Pick Button (PICK)

- Press this button when substituting a track with the time edit. (Refer to Page 11, 12.)

19 Link Button (LINK)

- Press this button when editing spans a number of discs. (Refer to Page 12.)

20 +10 Button (+10)

- Press this button first when selecting track numbers over 10. Use it together with the number buttons 0-9. For example, to select track number 15, press [+10] then [5]. For track number 33, press [+10] three times, then press [3].

21 Index Button (INDEX)

- Press this button to start playback from an index within a track. Use the number buttons 0-9 to specify the index number.

22 Program/Direct Button (PROG/DIRECT)

- Press this button when you want to enter tracks for programmed playback. (Refer to page 9 for details.)

23 Pitch - Button (PITCH -)

- Press this button to slow down the playing speed. (Refer to Page 13.)

24 Pitch + Button (PITCH +)

- Press this button to make the playing speed faster. (Refer to Page 13.)

25 Fader Button (FADER)

- Press this button to perform fade out or fade in. (Refer to Page 12.)

26 Repeat Button (REPEAT)

- Press this button to repeat playback of all tracks.
- When this button is pressed, [REPEAT] lights on the display and all tracks on the disc or in a program will be repeatedly played back. Press this button once more to disengage the Repeat All function.

27 Headphones Jack (PHONES)

- For private listening, you can connect your headphones to this jack. Do not raise the volume level too much when listening through headphones. (Headphones are sold separately.)

28 Volume Control (PHONES LEVEL)

- Use this to adjust the output level (VOLUME) of the headphones.

29 Output Terminal (FIXED-VARIABLE)

- Connect these jacks to the input jacks on your amplifier. (Refer to page 8 for details on the connections.)

30 Digital Output Jack (COAXIAL)

- This jack outputs digital data.
- We recommend using a 75-ohm pin cord (available in stores) for connections.

31 Digital Output Jack (OPTICAL)

- Digital data is output in optical form from this jack.
- Contact your nearest Denon Consumer Center or office for information on the optical fiber cable to be used for connection.

32 Trap Door

- Press the right edge to open the door.
- To close it, press on the right edge. A click is heard to indicate that the door is closed.

33 Side Wood

(DCD-2060G only).

Continuous Button Operation

If the automatic search reverse button 7, the automatic search forward button 8, the pitch - button 23, the pitch + button 24 or the +10 button 20 are held in, the function of that button will be repeated.

CONNECTION

(1) Connecting the Output Terminal (FIXED-VARIABLE)

Use the included pin cords to connect the left (L) and right (R) output terminal (FIXED-VARIABLE) of the DCD-1290/2060/2060G to the CD, AUX, or TAPE PLAY left (L) and right (R) input jacks of the amplifier. There are two types of output jacks, one of the variable type and one of the fixed type. Be sure to use the variable outputs if you want to be able to control the output level from the DCD-1290/2060/2060G.

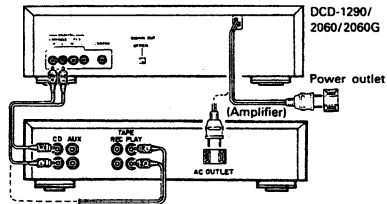

(2) Connecting the Digital Output Jack (COAXIAL)

Use a 75-ohm pin cord to connect the digital output jack (COAXIAL) of the DCD-1290/2060/2060G to the digital input jack (COAXIAL) on a digital processor or D/A unit, available in stores.

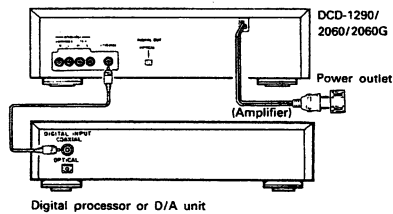

(3) Connections to the Digital Optical Output Jack (OPTICAL)

Use an optical fiber cable to connect the digital optical output jack on the DCD-1290/2060/2060G to the optical input jack on a digital processor or D/A unit.

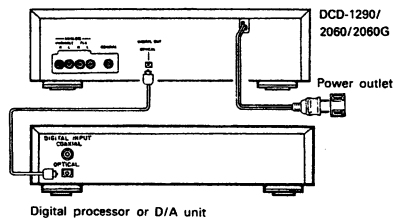

Connection Precautions

- Before proceeding with connections or disconnections of cables and power cords, be sure to turn all system components off.
- Ensure that all cables are connected properly to the L (left) and R (right) jacks.
- Insert plugs fully into the terminals.
- Connect the output jacks to the amplifier CD, AUX or TAPE PLAY input jacks.

OPENING AND CLOSING THE DISC HOLDER AND LOADING A DISC

Opening and closing the disc holder (This operation only works while the power is on.)

1. Press the power switch (POWER) to turn on the power.
2. Press the open/close button (▲ OPEN/CLOSE).

How to load a disc

- Make sure the disc holder is completely open.
- Hold the disc by the edges and place it on the disc tray. (Do not touch the signal surface, i.e., the glossy side.)
- When using 12 cm. diameter discs, make sure the outer edge matches the tray guide circumference (Fig. 1), and when using CD singles (8 cm. diameter) match the outer edge with the inner tray guide circumference. (Fig. 2)
- Press the open/close button (▲ OPEN/CLOSE) to close the disc holder.
- When the disc holder is closed, the disc is read and after a few seconds the number of tracks and total playing time are displayed on the TRACK NO. and TIME displays, respectively.
- When the disc holder is open and a disc is loaded, you may also press the play (▶ PLAY) or pause (⏸ PAUSE) button to close the disc holder. (If the play button (▶ PLAY) is pressed, playback will start immediately upon the disc contents having been read.)

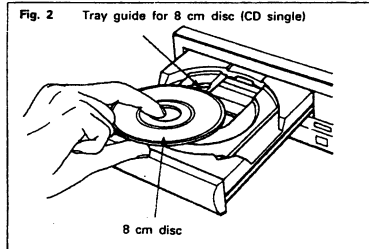
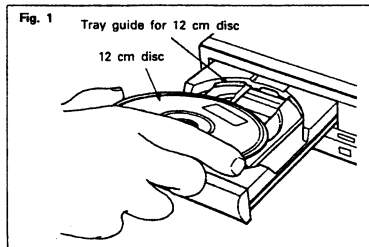

Caution:

- If your finger should get caught in the disc holder when it closes, press the open/close button (▲ OPEN/CLOSE).
- Do not place any foreign objects on the disc tray, and do not place more than one disc on the tray at a time. Otherwise malfunction may occur.
- Do not push in the disc tray manually when the power is off as this may cause malfunction and damage the CD player.

NORMAL CD PLAYBACK

(1) Starting Playback

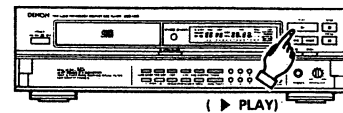

1. Press the power switch (POWER) to turn on the power.
2. Load the disc you want to play.
- When the disc holder is closed, the disc is read and the number of tracks and total playing time of the disc are displayed.
3. Press the play button (▶ PLAY).

(2) Stopping Playback

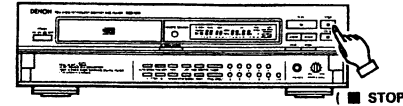

1. Press the stop button (■ STOP).
- When all tracks have been played on a disc, playback will stop by itself.

Precautions:

- If no disc has been loaded or the disc has been placed upside down, all indicators will light.
- When the information on the disc cannot be read correctly, for example due to dust or dirt on the disc, the indicators will read as shown below. Nothing will be shown on the TRACK NO. and TIME displays, and it may take quite a while to read the disc.

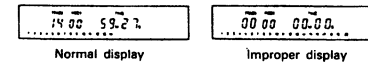

ADVANCED CD PLAYBACK

① Playing a Specific Track Direct Search

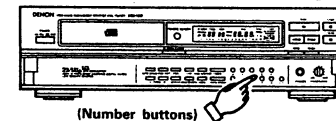

- Use the number buttons and the +10 button to input the number of the desired track.
- For example, to play track number 4, press [4], and to play track number 12, press [+10] and [2]. Playback will begin from that track.

② Advancing to the next track during playback Automatic Search

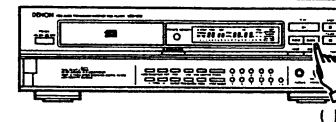

- Press the Automatic search forward button (▶▶) during playback.
- The pickup will advance to the beginning of the next track and playback will continue. Pressing the button several times will forward the pickup the corresponding number tracks.

③ Returning to the beginning of the current track during playback Automatic Search

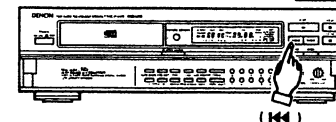

- Press the Automatic search reverse button (◀◀) during playback.
- The pickup will return to the beginning of the current track and playback will continue. Pressing the button several times will return the pickup the corresponding number tracks.

④ Playing Specific Tracks in a Specific Order Programmed Play

- With this function, you can choose any of the tracks on the disc and program them to play in any order.
- Programming is possible with the disc holder open.
- Up to 20 tracks can be programmed.

- The programmed tracks are shown on the calendar.

(1) Programming

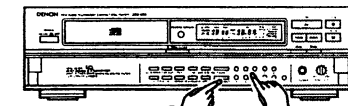

(PROG/DIRECT) ① (Number buttons) ②

- Press the PROG/DIRECT button so that the [PROGRAM] indicator lights, then use the number buttons and the +10 button to program the tracks.

For example, to program tracks 3, 12, and 7, press [PROG/DIRECT], [3], [+10], [2], and [7]. The corresponding track number lights on the calendar each time a track is programmed, the track number is displayed on the TRACK NO. display, the number of tracks programmed is displayed on the INDEX display, and the total playing time of the programmed tracks is displayed on the TIME display. A few seconds after the last track has been programmed, the total number of tracks programmed is displayed on the TRACK NO. display and the total playing time of the programmed tracks is displayed on the TIME display.

(2) Checking the Programmed Tracks (Remote control only)

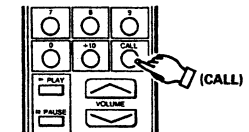

- Press the CALL button. The programmed tracks are displayed in order on the TRACK NO. display each time the CALL button is pressed.

(3) Playing the Programmed Tracks

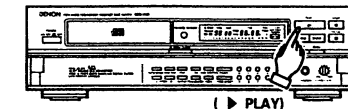

- Press the (▶ PLAY) button to play the tracks in the programmed order.

(4) Clearing the Program

- The entire program is cleared when the PROG/DIRECT button is pressed again. The program is also cleared when the (▲ OPEN/CLOSE) button is pressed.
- If the PROG/DIRECT button is pressed during programmed play, the program is cleared and playback continues normally through to the last track on the disc.

NOTES

- If programming is done in the play or pause mode, the track currently playing is programmed at the first position. Other tracks can be added to the program, but the number of programmed tracks and the playing time will not be displayed.
- Direct search is not possible during programmed play. If the number buttons are pressed, that track is added to the end of the program.
- Programming is possible with the disc holder open. Track numbers greater than the number of tracks recorded on the disc can be programmed, but will be automatically cleared before playback begins.
- The remaining time per track will only be displayed for track numbers 1 through 20.
- The total program time and remaining program time are not displayed if tracks greater than track number 20 are programmed.

6 Repeating playback Repeat

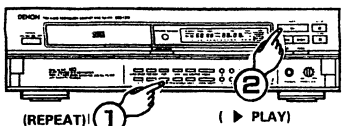

- Press the repeat button (REPEAT).
 - Press the play button (▶ PLAY).
- Pressing the repeat all tracks button (REPEAT), [REPEAT] is displayed.
 - Steps ① and ② above may be reversed.
 - To cancel repeat playback of all tracks, press the repeat button (REPEAT) once more.
 - Pressing the repeat button (REPEAT) during programmed playback, playback of the tracks entered into the memory will be repeated.

6 Pausing playback at any point Pause

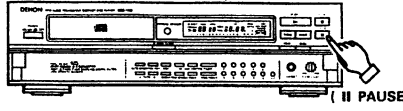

- Playback can be temporarily halted and then continued from the same point in the track.
- Press the pause button (|| PAUSE) during playback.
 - To continue playback, press the play button (▶ PLAY) or the pause button (|| PAUSE) once more.

7 Audible quick search Manual Search

- Using this function, you can cue to a desired point within a track, either in the forward or reverse direction.
- Release the manual search button (◀◀ or ▶▶) when the desired point has been reached. Normal playback then continues.

(1) Manual Search Forward

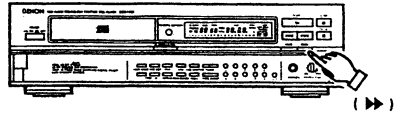

- Press the manual search forward button (▶▶) during playback. Playback of the track is sped up.
- As a reference, the current track number and elapsed playback time within the track are displayed.
- Manual search forward is approximately three times faster when engaged during the pause state compared to playback. In this case, no sound is heard however.
- If the manual search forward button (▶▶) is kept pressed after the end of the final track on the disc is reached, [JJ] is displayed and manual search stops. To return to another point, press the manual search reverse button (◀◀) until [JJ] disappears.

(2) Manual Search in Reverse

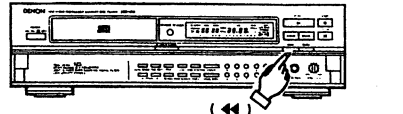

- Press the manual search reverse button (◀◀) during playback. Reverse playback of the track is sped up.
- As a reference, the current track number and elapsed playback time within the track are displayed.
- Manual search in reverse is approximately three times faster when engaged during the pause state compared to playback. In this case, no sound is heard however.

- If the manual search reverse button (◀◀) is kept pressed after the beginning of the first track on the disc is reached, [CC] is displayed and manual search stops. To return to another point, press the manual search forward button (▶▶) until [CC] disappears.

8 Finding Sections Within a Track Index Search

- Use this function to start playback from certain sections within a track divided by index numbers.

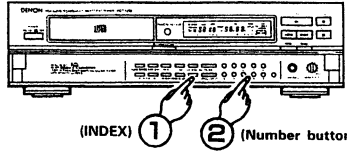

- Press the INDEX button. "--" appears at the TRACK NO. display.
 - Use the number buttons to specify the track number. "--" now appears at the INDEX display. Input the desired index number. Playback starts from there.
- For example, to start listening from index number 2 on track 3, press INDEX, 3 and 2.

Indexes

- Indexes are numbers which are assigned to sections within a track. Check the disc's explanatory notes for the index numbers.
- If you make an index search for an index number that is not on the disc, playback will start from the last index number on the track.

9 Inserting blanks between tracks Auto Space

- This is convenient feature that will insert 4-second blanks between tracks, which can be used when recording compact discs on tape.

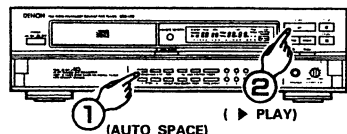

- Pressing the auto space button (AUTO SPACE) will cause the [AUTO SPACE] indicator to light.
- Press the play button (▶ PLAY) to start playback. When a track has been played to its end, a 4-second silence is made before the next track starts playing.
- Press the auto space button (AUTO SPACE) again to cancel the function.

10 Searching and Pausing at the Beginning of the Track Pause

(1) With Direct Search

- In this case, the set pauses at the beginning of the track found with the direct search operation.

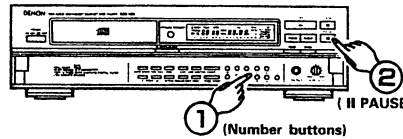

- Press the number button(s) for the desired track.
- Press the (|| PAUSE) button.
- To start playback, press the (▶ PLAY) or (|| PAUSE) button.

(2) With Program Search

- Press the (|| PAUSE) button after the program search operation is completed. The set will pause at the beginning of the first programmed track.

11 Playing in Random Order Random Play (Remote control only)

- With this function, the tracks recorded on the disc can be played in a completely random order.

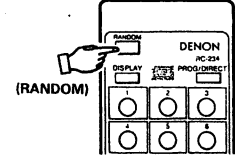

- When the RANDOM button is pressed, the [RANDOM] indicator lights and random play begins automatically.
- If the RANDOM button is pressed when tracks have been programmed, only the programmed tracks will be played, in random order.
- If the RANDOM button is pressed when the repeat function is set, the tracks will be played through once in random order, then played through again in a different order, etc.
- During random play, all of the tracks on the disc are displayed rapidly on the TRACK NO. display, and the track which will be played next cannot be known until playback starts.

- NOTE:**
- The remaining time in the total mode cannot be displayed during random play.
 - If the RANDOM button is pressed when in the time edit mode, the time edit mode is cleared.

12 Edit Recording on Sides A and B of the Tape Edit Function

(1) Editing by Tape Time Specification (TIME EDIT)

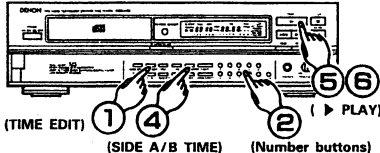

- The time edit function permits highly efficient editing in conjunction with the length (tape time) of the cassette tape to be recorded.
- When the TIME EDIT button is pressed, [C-...] will appear and the player will wait for the tape time to be input. [EDIT] will light up.
 - Input the tape time with the number buttons. (The tape time is the total time of sides A and B.)
- Example: For a 46-minute tape, press 4 and 6.

Example of tracks being placed in the blank spaces

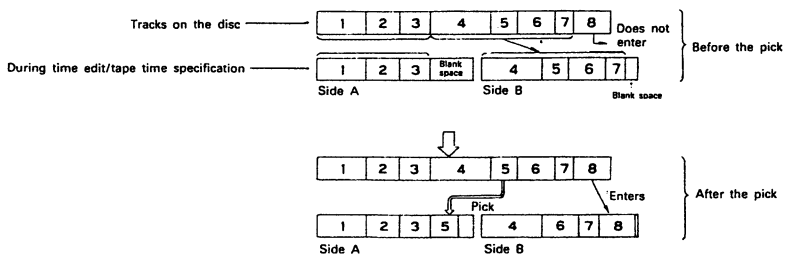

- When the tape time has been specified, the tracks of side A that can be recorded are displayed on the calendar and the blank time of tape side A is displayed at TIME. (R-) is displayed at TRACK NO. and the number of tracks that can be recorded are displayed at INDEX.

- Pressing the SIDE A/B TIME button permits a check of the calendar display of the tracks that can be recorded on side B and the blank time. (b-) is displayed at TRACK NO. and the number of tracks that can be recorded are displayed at INDEX.

- Each press of this button alternately displays side A and side B.
- Pressing the play button (▶ PLAY) starts the play from the first track of side A. When side A has finished playing, the player will automatically pause at the beginning of the first track of side B.

- Pressing the play button (▶ PLAY) or the pause button (|| PAUSE) again will start the play mode. When side B has finished playing, the player automatically stops.

When a mistake has been made in the time specification and the play button (▶ PLAY) has not yet been pressed, pressing the TIME EDIT button will return the settings to the condition of Step 1. This can be done any number of times.

- The time edit function also works in the program track selection mode (Page 7). In this mode, sides A and B can be divided according to the program order. When the auto space function has been turned on, 4 seconds will be added to the play time of each track.

NOTE:

- The time edit function will not work for discs containing more than 20 tracks.
- The automatic search buttons (◀◀, ▶▶) and the manual search buttons (◀◀, ▶▶) do not function during the time edit operation.
- Pressing the stop button (■ STOP) or the open/close button (▲ OPEN/CLOSE) (except for at the time of the link operation) will cancel the time edit operation.

(2) Pick Function (PICK)

In (1) time edit, the tracks are ordered from the first track or in the programmed order so that a large blank space might remain at the end of the tape. The pick function is used to shorten this blank space and effectively use the time of the specified tape.

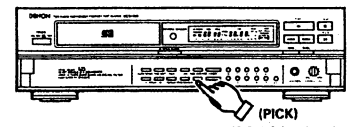

- In (1) time edit, press the pick button (PICK) following the tape time specification and before pressing the play button (▶ PLAY).
- When the display is showing side A, pick is executed from among the tracks other than those fixed on side A (in the blank portion of side A). When the display is showing side B, pick is executed from among the unfixed tracks (in the blank portion of side B).

- ③ When there are no tracks that can be picked in the blank portion of side A (side B), cancel the last track of side A (side B), increase the blank portion, and pick an available track in the new blank portion. At this time the tracks cancelled from side A are automatically fixed on side B.
- When there are no tracks that can be picked even though the last track of side A (side B) has been cancelled, the setting will remain the same even if the cancellation is suspended.

Example of tracks not being placed in the blank spaces

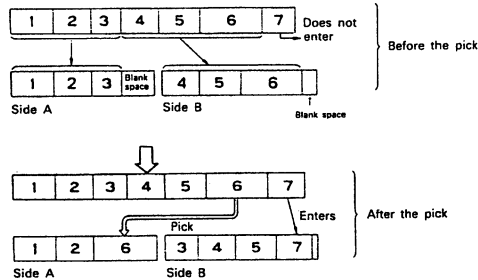

When tracks are not placed in blank spaces as shown in the diagram to the right, the last track (track 3 in the example) is cancelled and substituted with a track from side B.

(3) Link Function (LINK)

The link function provides the convenience of editing a number of discs in succession.

The link operation is used following the tape time specification of the time edit function and before the end of playback.

- When the link button (LINK) is pressed, [EDIT] will start flashing.
- After the tracks have been played, the player will stop automatically. The blank time of the tape will be displayed at this time.
- Press the open/close button (▲ OPEN/CLOSE) of the disc holder and change the disc.
- Pressing the time edit (TIME EDIT) button will permit editing using the blank time of the tape in Step ②.

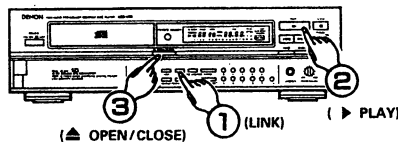

NOTE:

- The link operation is cancelled by the stop button (■ STOP). It will also be cancelled if the disc holder is opened during play.
- When editing has not been performed as far as side B with the time edit (i.e., only for part of side A), editing will be done within the blank time of side A and the blank time of side B.
- When editing has been performed as far as side B with the time edit, the blank time of side B will be used for editing.

(10) Fading Out or Fading In at the

Desired Location **Fader Function**
(Analog output only)

- (1) Fading out and fading in is possible at the desired position during play (MANUAL FADER)

① Fade Out

When the fader button (FADER) is pressed during play, fade out will be provided for about 5 seconds. [FADE] will light up during the operation and (▶) will flash. When fade out is completed the player will automatically pause.

② Fade In

When the fader button (FADER) is pressed from the pause mode, the player will start playing and fade in will be provided for about 3 seconds. [FADE] will light up during the operation and (◀) will flash.

(2) Setting the Fade Out Time in Advance (TIME FADE)

- When the fader button (FADER) is pressed in the stop mode, the [FADE] indicator ([FADE]) will light up, TIME will appear as —M—S, and the player will wait for the input of the fade out time.
- Input the fade out time with the [0-9] number buttons.
- Pressing the play button (▶ PLAY) will start the playback and the FADE indicator ([FADE]) will light up.
- The (▶) indication will start flashing 5 seconds before the specified fade out time and then the fade out will begin. The fade out will end at the specified time and the player will automatically pause.

The time fade function will be cancelled if an auto search or manual search is performed during playback.

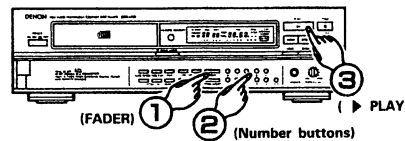

(11) To Search for the Peak Level of the Disc

- The player searches for the peak portion and plays a few seconds either side of this point repeatedly. This is convenient for making recording adjustments on the tape recorder.

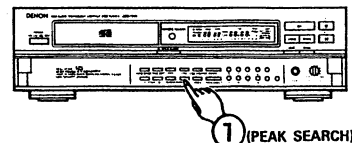

- When the peak search button (PEAK SEARCH) is pressed in the stop mode, the PEAK indicator will flash and the player will search for the portion having the peak level.
- After the search, the PEAK indicator lights up and a few seconds either side of the peak level point are played back repeatedly. This is convenient for making recording adjustments on the tape recorder.
- To cancel the peak search, press the stop (■ STOP) button.
- When the play button (▶ PLAY) or the pause button (⏸ PAUSE) is pressed during peak search or while playing the peak portion back repeatedly, the player will go to the beginning of the first track (the first track of the program for program playback, or the track that was first selected in the time edit) and begin playback from here if the play button was pressed or enter the pause mode if the pause button was pressed.

NOTE:

- The peak search function reads the level of the disc from the beginning of the disc to the end at a fixed interval and regards the maximum value that was read as the peak. Peak search takes a little time for this reason.
- The peak portion may change each time the disc is read and there may be a difference in the actual peak level, but since this difference is slight it will not effect the adjustment of the record level except with certain discs which have very long quiet sections with only a very occasional high peak level. In this case a manual search of the disc to find high peak is suggested.
- The time fade function is cancelled when the peak search operation is performed. To use the time fade function, set to the stop mode then reset the function.
- Buttons other than the open/close button (▲ OPEN/CLOSE), play button (▶ PLAY), pause button (⏸ PAUSE), and stop (■ STOP) button will not function during peak search or repeat play of the peak portion.

(12) Changing the Speed of Playback **Pitch Control**

- Playback can be speeded up or slowed down.

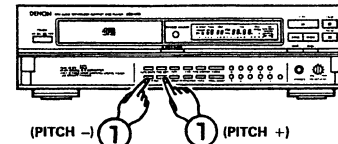

- Press the PITCH + or PITCH - button during the play or pause mode to change the speed of playback.
- When one of the PITCH buttons is pressed, the amount of the speed change appears on the seconds section ("S") of the TIME display for approximately 2 seconds. "PITCH -" appears when the speed is slower than normal, "PITCH +" when the speed is faster than normal. The speed can be changed in steps of 0.1% from -12.0% to +12.0%.
- Press the PLAY button (▶ PLAY) during playback with a different speed to return to normal speed playback. Also, the speed setting is cancelled if the stop mode is set during playback at a different speed.

NOTES

- No data is output from the digital output jack (OPTICAL/COAXIAL) during playback with a different speed (when "PITCH" is lit). If you want to output data, press the PLAY button (▶ PLAY) to return to normal speed playback.
- The pitch also changes when the speed is changed.
- If the speed is changed during the time edit operation, the total playing time changes, so the time of the blank space is not calculated accurately.
- The time display (elapsed playback time, remaining time per track, or total remaining time) will not be accurate during playback with a different speed.
- A maximum of 1 second is required to return to the normal speed when the PLAY button (▶ PLAY) is pressed during playback with a different speed. During this time, only the OPEN/CLOSE (▲ OPEN/CLOSE) and STOP (■ STOP) buttons will function.

TIMER-CONTROLLED PLAYBACK

■ Operation

- Turn on the power of all system components.
- Set the input selector on the amplifier to correspond to the inputs the CD player is connected to.
- Make sure a disc has been loaded in the disc holder.
- Check the time on the timer and then set the desired turn-on time.
- Turn the audio timer ON. Power is turned off automatically in all components connected to the timer.
- When the preset turn-on time is reached, power is turned on in the system components, and CD playback starts from the first track.

■ Connection

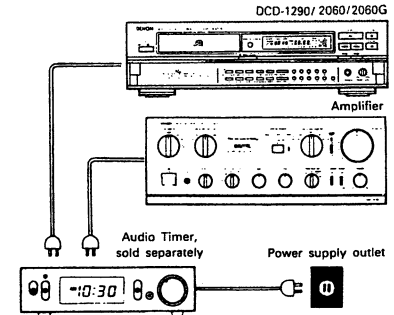

THE COMPACT DISC

1. Precautions on handling compact discs

- Do not allow fingerprints, oil or dust on the surface of the compact disc. If the signal surface is dirty, wipe it off with a soft, dry cloth. Wipe in circular motions from the center and out.
- Use of DENON'S AMC-2021 CD cleaner is recommended.
- Do not use water, benzene, thinner, record sprays, electrostatic proof chemicals, or silicone-treated cloth to clean discs.
- Always use care when handling discs to prevent damaging the surface, in particular when removing a disc from the case and returning it.
- Do not bend compact discs.
- Do not apply heat to compact discs.
- Do not enlarge the hole in the center of the disc.
- Do not write on the disc and do not attach any labels.
- Condensation will form on the disc surface if it is brought into a warm room from a cold area, such as outdoors during winter. Wait until the condensation disappears. Never dry discs with hair dryers, etc.

2. Precautions on storage

- After playing a disc, always return it to its case.
- Keep discs in the cases when they are not to be played. This will protect them from dust and dirt and prolong their service life.
- Do not store discs in the following places:
 - Places exposed to direct sunlight for a considerable time.
 - Places subject to accumulation of dust or high humidity.
 - Places exposed to high temperatures, such as close to heater outlets.

PLAYBACK USING THE REMOTE CONTROL UNIT

The accessory RC-234/235 remote control unit can be used to control the CD player from a convenient distance.

(1) Inserting the dry cell batteries

1. Remove the battery cover on the back of the remote control unit.

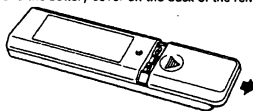

2. Insert two R6P (standard size AA) dry cell batteries with correct polarity as indicated inside the battery compartment.

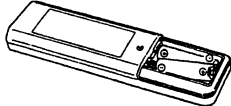

3. Replace the battery cover.

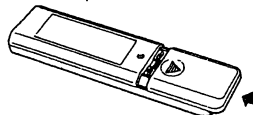

Notes on the Batteries

- The remote control unit uses standard size AA dry cell batteries.
- The batteries will need to be replaced approximately once a year. Replacement may be necessary earlier depending on how much the remote control unit is used.
- If, in less than a year from the time new batteries were inserted, the remote control fails to operate the CD player from a near-by position, it is time to replace the batteries.

- Insert the batteries properly, following the polarity diagram inside the battery compartment, in other words make sure (+) and (-) terminals are properly aligned.
- Batteries are prone to damage and leakage. Therefore:
 - Do not combine new batteries with used ones.
 - Do not combine different types of batteries.
 - Do not jumper opposite poles of the batteries, expose them to heat, break them open nor expose of them in open fire.
- If the remote control unit is not to be used for a long period of time, remove the batteries from the unit.
- If the batteries have leaked, remove any traces of battery fluid from the battery compartment, wiping thoroughly with a dry cloth. Then insert new batteries.

(2) Directions for Use

- Operate the remote control unit while pointing it towards the remote control sensor on the CD player (see below).

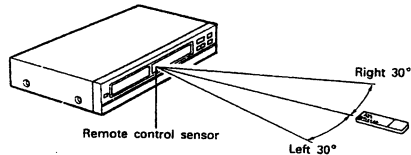

When a remote control signal is received, the remote control indicator on front of the CD player lights briefly.

- The remote control unit can be used at a distance up to 8 meters in a straight line from the CD player. This distance decreases if there are obstructions blocking the signal path or when the remote control unit is operated at an angle from the remote control sensor.
 - The buttons on the remote control unit have identical functions with those on the CD player.
- However, the following functions cannot be remote controlled: Power ON/OFF.

REMOTE CONTROL UNIT RC-234/235

- Press this button to change the brightness of the display.
- Press once to make the display 2/3 as bright as normal.
- Press again to make the display 1/3 as bright as normal.
- Press once again to turn the entire display off during playback and all but the track number off in any other mode.

- Random button (RANDOM)
- Display Button (DISPLAY)
- Number Buttons (0 ~ 9)
- Play Button (▶ PLAY)
- Pause Button (⏸ PAUSE)
- Stop Button (■ STOP)
- Pitch - Button (PITCH -)
- Pitch + Button (PITCH +)

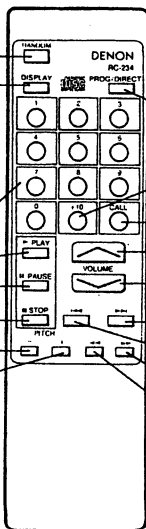

Setting to the Program Mode

- For program search, press the PROG/DIRECT button then the number buttons (0 through 9 and +10).
- The remote control unit is normally set to the direct mode.

Program/Direct Button (PROG/DIRECT)

+10 Button

Call Button (CALL)

Volume Buttons (+)

Volume Buttons (-)

Automatic Search Forward Button (▶▶)

Automatic Search Reverse Button (◀◀)

Manual Search Forward Button (▶)

Manual Search Reverse Button (◀)

Track Selection

Use the numeric track buttons (0 ~ 9 and +10) while programming and to access a desired track almost instantly.

The track search buttons (▶▶ and ◀◀) are best used to advance or return from the current track to the next track.

The level of the Variable Output Terminal output can be varied. Pressing the (+) button increases the volume and pressing the (-) button decreases the volume.

Checking Programmed Contents

By pressing the CALL button on the remote control unit, programmed contents will be displayed. Tracks entered into the memory, will be displayed starting from the first track entered, and will advance one step at a time each time the CALL button is pressed.

Notes on Operation

- Do not press identical buttons on the CD player and remote control unit simultaneously as this may cause malfunction.
 - The remote control unit may be difficult to operate if the remote control sensor is exposed to strong light, such as direct sunlight or light from fluorescent lamps, or if there are obstacles between the remote control unit and the sensor.
 - **Direct track selection**
Using the track number buttons (0 ~ 9, +10), tracks can be directly assigned for playback.
 - **Track selection while programming**
Press the program button (PROG/DIRECT) and then the track numbers you wish to enter into the memory.
Example: PROG/DIRECT → 3 → +10 & 1 → 5 ...
(Tracks 3, 11, 5 and so on are entered into the memory.)
- Memorized tracks are erased by pressing the PROG/DIRECT button (PROG/DIRECT).

INSTALLATION PRECAUTIONS

The CD player uses a microcomputer for controlling internal electronic circuits. In the event that the player is used while a near-by tuner or TV is turned on, although unlikely, interference could occur either in the sound from the tuner or the picture of the TV. To avoid this, please take the following precautions.

- Keep the CD player as far away from the tuner or TV set as possible.
- Keep the power cable and connecting cable of the CD player separate from the antenna wires of the tuner and TV.
- Interference is particular likely to occur when an indoor antenna or a 300-ohm feeder cable is used. Thus, use of an outdoor antenna and 75-ohm coaxial cable is strongly recommended.

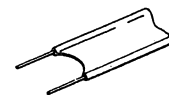

300-ohm feeder cable

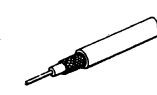

75-ohm coaxial cable

TROUBLESHOOTING

If the CD player does not seem to be functioning properly, check the following:

- Disc holder does not open or close.**
 - Is the power on?
- When a disc is loaded, 00000000 is displayed.**
 - Is the disc loaded properly? See page 8
- When the play button (▶ PLAY) is pressed, playback does not start.**
 - Is the disc dirty or scratched? See page 13
- There is no sound, or it is distorted.**
 - Is the output cord properly connected to the amplifier? See page 8
 - Have the amplifier controls been set correctly?

A specific section of the disc will not play.

- Is the disc dirty or scratched? See page 13
- Programmed playback does not work.**
 - Have programming been properly done? See pages 9 and 15
- Incorrect operation when buttons on the remote control are pressed.**
 - Is the remote control unit being operated too far from the CD player? See page 14
 - Are there obstacles blocking the ray?
 - Is the remote control sensor exposed to strong light?
 - Are the batteries exhausted?
- No data is output from the digital output jack (COAXIAL)**
 - Is the pin cord properly connected? See Page 8.
 - Have you changed the speed of playback? See Page 13.

SPECIFICATIONS

	DCD-1290/2060	DCD-2060G
AUDIO		
No. of Channels:		2 channels
Frequency Response:		2 ~ 20,000 Hz
Dynamic Range:		100 dB
Signal-to-Noise Ratio:		110 dB
Harmonic Distortion:		0.0025% (1 kHz)
Separation:		105 dB (1 kHz)
Wow & Flutter:		Below measurable limit: ($\pm 0.001\%$ W. peak)
Output (Analog):		FIX. 2.0 V, VARIABLE 0 ~ 2.0 V
(Digital):		COAXIAL (0.5 Vp-p 75 ohm) OPTICAL
DISCS		
		Compact Disc format
GENERAL CHARACTERISTICS		
Power Supply:		50/60 Hz, Voltage is shown on rating label.
Power Consumption:		15W
Dimensions:	434 (17-3/32") W x 122 (4-51/64") H x 320 (12-19/32") D mm	470 (18-1/2") W x 122 (4-51/64") H x 320 (12-19/32") D mm
Weight:	6.7 kg (15 lbs 4 oz)	7.3kg (16lbs 1 oz)
FUNCTIONS AND DISPLAY		
Functions:		Direct selection, automatic search, programmed playback, repeat playback, manual search, auto space, time mode, time edit, pitch control, peak search, fader
Display:		Track number, time, music calendar, and engaged modes
Others:		Headphones jack
REMOTE CONTROL UNIT		
Remote Control System:		RC-235 (For Europe and U.K.) RC-234 (For U.S.A., Canada, Australia and Multi-Voltage)
Power Supply:		Infrared pulse system 3 V DC; two R6P (standard size AA) dry cell batteries
External Dimensions:		48 (1-57/64") W x 177 (6-31/32") H x 18 (45/64") D mm
Weight:		100 g (including batteries)

* Design and specifications are subject to change without notice in the course of product improvement.

NOTE FOR HANDLING OF LASER PICK-UP
DESCRIPTION OF THE COMPONENTS

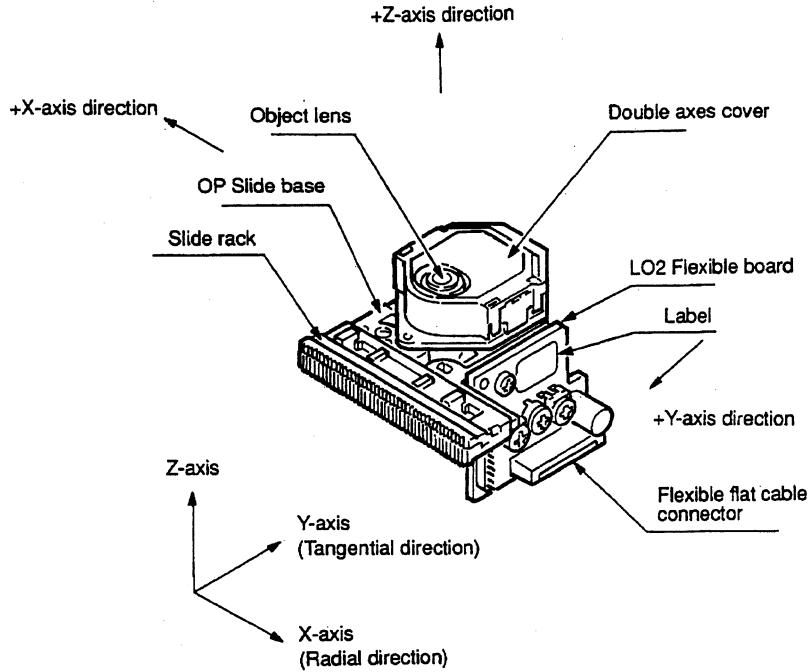

Label

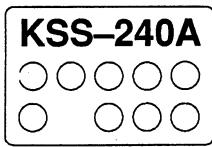

Lot No.
 lot

year
 (last figure)
 day month | quality control No.
 ○ ○ ○ ○ ○

but Oct. Nov. and Dec. are expressed by alphabetical letters of X, Y and Z.

quality control 10 1 10⁻¹
 ○ ○ ○
 LD drive current

PIN CONNECTOR

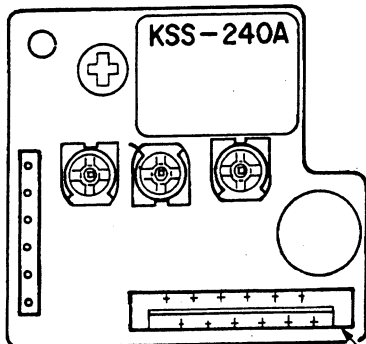

1 3 5 7 9 11
 2 4 6 8 10 12

Flexible flat cable connector

The expressed unit is by mA, with omission of the decimal point as for example, 56.5mA will be expressed as 565, but the head of English letter means the control in the manufacturing plant.

Pin No.	Description	Input/Output	Pin No.	Description	Input/Output
1	VC (+2.5V)	OUT	7	Vcc (+5V)	N
2	TE (TRK ER signal)	OUT	8	LDC (LD Control)	N
3	FE (FCS ER signal)	OUT	9	FCS+ (Double axes)	N
4	FZC (FZC signal)	OUT	10	TRK+ (Double axes)	N
5	RF (RF signal)	IN	11	TRK- (Double axes)	N
6	GND	IN	12	FCS- (Double axes)	N

Caution for Handling the Laser Pick-up

The laser pick-up KSS-240A is assembled and precisely adjusted using a sophisticated manufacturing process in our plant. Do not disassemble or attempt to readjust it. Please keep the following instructions carefully in handling pick-up.

1. Handle with Care

- (1) Storage
Do not store the pick-up in dusty, high-temperature or high-humidity environments.
- (2) Please take care for preventing from shock by falling down or careless handling.

2. Laser Diode (LD)

- (1) Protect your eyes
The laser beam may damage the human eye, since the intensity of the focused spot may reach $7 \times 10^3 \text{ W/cm}^2$ even if the intensity at the objective lens is $400 \mu\text{W}$ maximum. As the light beam spreads after focused through the objective lens, it does not effect you in the place as far as more than 30 cms. However, do not look at the laser light beam either through the objective lens directly nor another lens or a mirror.
- (2) Poison of As
Since the LD chip contains As (Arsenic), as GaAs + GaAlAs, as known as the poison, although the poison is relatively weak, in comparing with others, e.g. As_2O_3 , AsCl_3 etc., and the amount is small, avoid putting the chip in acid or an alkali solution, heating it over 200°C or putting it into your mouth.
- (3) Avoid surge current or electrostatic discharge
The LD may be damaged or deteriorated by its own strong light if a large current is supplied to it, even if only a short pulse.
Make sure that there is no surge current in the LD driving circuit by switches or else. Be careful to handle pick-up as it may be damaged in a moment by human electrostatic discharge. The pins of the LD are short-circuited by solder for protection during shipment.
For safety handling of an LD, grounding the human body, measuring equipments and jig is strongly recommended. And still it is further desirable to make use of mat on the platform and floor for handling the LD.
To open the short circuit, remove the soldering quickly with a soldering iron whose metal part is grounded.
The temperature of the soldering iron should be less than 320°C (30W).

3. Actuator

- (1) The performance of the actuator may be effected if magnetic material is located nearby, since the actuator has a strong magnetic circuit. Do not permit dust to enter through the clearance of the cover.
- (2) Cleaning the lens
It may change the specifications by attaching dust or ash on the objective lens. Clean the lens with a cleaning paper dampened with a little water, not pressing lens with so much strength by the cleaning paper.

4. Metal Bearing

As the metal bearing of Cu-compound sintered alloy is impregnated with FROIL946P (*Part No. 529 0054 007), never fail to supply the bushing with the same lubricant at the time of replacing the pick-up.

5. Handling

Please handle the laser pick-up with holding the side base (rosin molded part).

When either a part of human body or some other things may happen to touch directly with the circuit part of P.W.Board, it may cause deterioration, take careful attention in handling this base.

6. Deterioration

As KSS-240A comprises built-in RF Amp and APC circuit, it resists stronger against external electrostatic damages than the former typed pickup. However, there is possibility of pickup distortion in the following cases.

- (1) Low HF level, or with great numbers of jitters.
- (2) Tracking offset (EF Balance) is out of order (Refer to "Confirmation Method of Adjustment " for confirmation on (1) and (2)).

DISASSEMBLY

● **Top Cover**

1. Remove 4 upper screws, rear screw, and 4 side screws.
(DCD-2060G 8 upper screws)
2. Remove Top Cover to arrow direction.

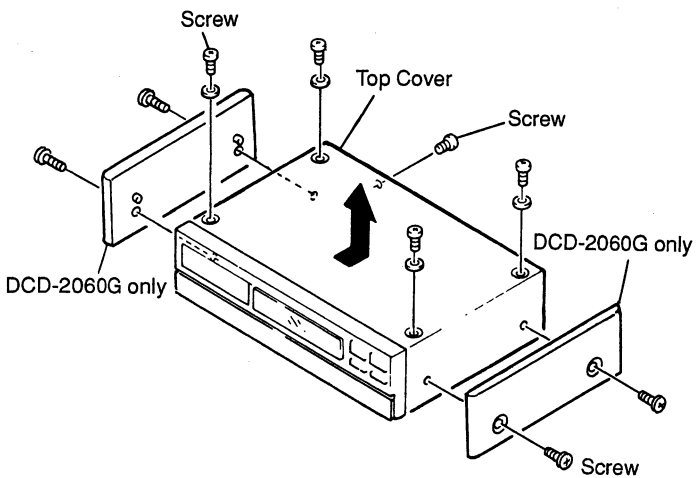

● **Mechanism Unit**

Remove 4 screws.

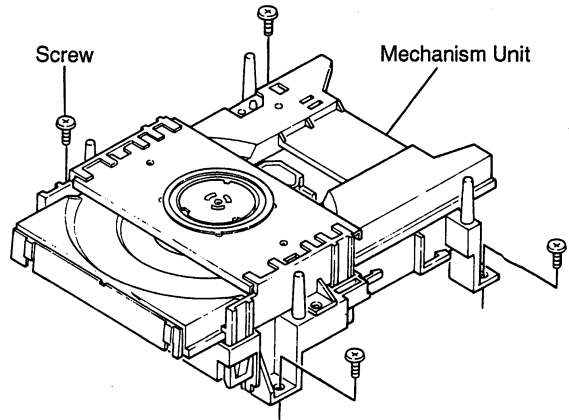

● **Front Cover**

1. Pull Loader frame frontward, and remove loader panel.
2. Remove 3 screws.
3. Remove Front Panel clear of upper and lower hooks.

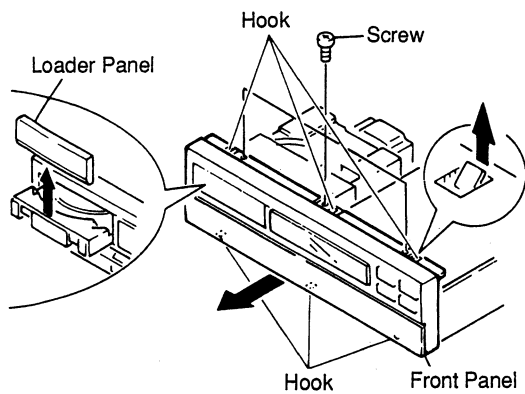

● **Clamper**

Pull clamper and undo 4 hooks.

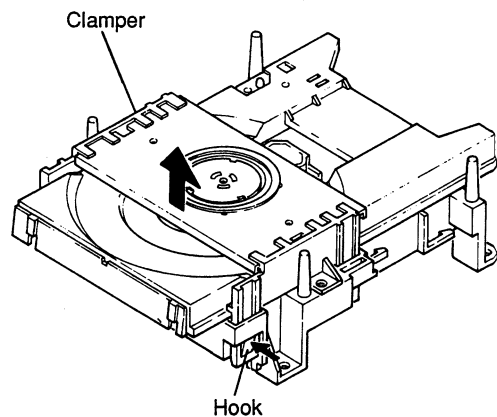

● **Bottom Plate**

Remove 8 screws.

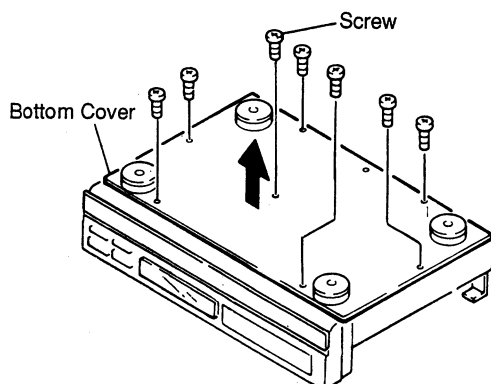

ADJUSTMENT

Microcomputer built in the unit, comprises service program to facilitate servo adjustment by pushing operation button.

1. Start service program

- (1) Turn power switch OFF.
- (2) Shortcircuit JV055 (SW.OPEN) and JV054 (SW.CLOSE) of TP102 on P.W.B. (Main Unit)
(Caution) Do not touch other jumper wires.
- (3) Turn power switch ON.
(Service program starts, and displays track number 01)

(Caution)

- When service program started normal operation of buttons will be defeated.

2. Service program function

Button	Function	Description
▲ OPEN/CLOSE	Opens or closes the disc holder.	<ul style="list-style-type: none"> ● Opens or closes only when disc is stopped. ● Operate other keys after open or close.
■ STOP	Stops system function.	<ul style="list-style-type: none"> ● Displays track number 01. ● Push when adjustment completed, or do it again.
▶ PLAY	Starts focus servo and disc turns.	<ul style="list-style-type: none"> ● Push when adjust tracking offset. ● When completed, displays track number 02.
PAUSE	Starts focus servo, tracking servo, slide servo, spindle servo.	<ul style="list-style-type: none"> ● When PLAY button is pushed, starts tracking servo and slide servo. ● When completed, track number 03.
Other button	No normal operation.	<ul style="list-style-type: none"> ● Do not operate buttons other than above. ● If misoperated, immediately turn power switch OFF.

(Caution)

- Do not use remote control during service program mode.

3. Adjustment

- (1) Location

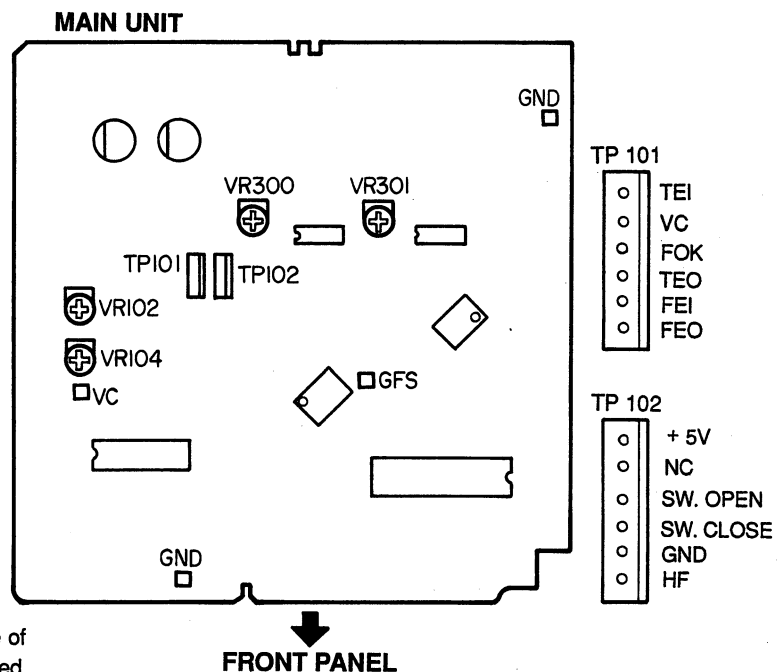

(Caution)

VR300, 301 are adjusted at the time of shipment ; readjustment is not needed.

(2) Necessary equipment for adjustment

1. Dual trace oscilloscope
2. Reference disc (CA-1094)
3. Oscillator (10 Hz ~ 10 kHz, 0 ~ 3 Vp-p)
4. Frequency counter (readable more than 5 KHz)
5. Filter for measurement

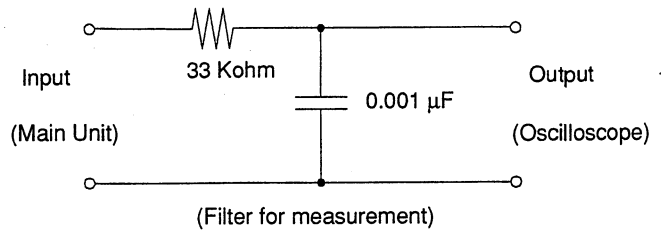

(3) Preset

1.	Start service program.	
2.	Preset VR102, 104 as per right figure.	VR102 (F-GAIN) 12 O'clock (VR104) (T-GAIN) 12 O'clock
3.	Step.	1. Focus gain (VR102) 2. Tracking gain (VR104)

4. Focus gain

Connection									
Oscillator	Counter	Oscilloscope	Adjust	Check	Step				
930 Hz 2 Vp-p (±0.1 V)	930 Hz	<table border="1"> <tr> <td>V</td> <td>H</td> </tr> <tr> <td colspan="2"> ● DC range ● X-Y mode </td> </tr> </table>	V	H	● DC range ● X-Y mode		VR102	(Oscilloscope) Y axis Phase 90° Waveform not right Y axis 	1. Push II PAUSE (Displays track number 03) 2. Set oscillator to 930 Hz/2 Vp-p 3. Switch oscilloscope input to X-Y mode. 4. Adjustment VR102 [F-GAIN] to symmetrize Lissajous figures to X and Y axes.
V	H								
● DC range ● X-Y mode									

5. Tracking gain

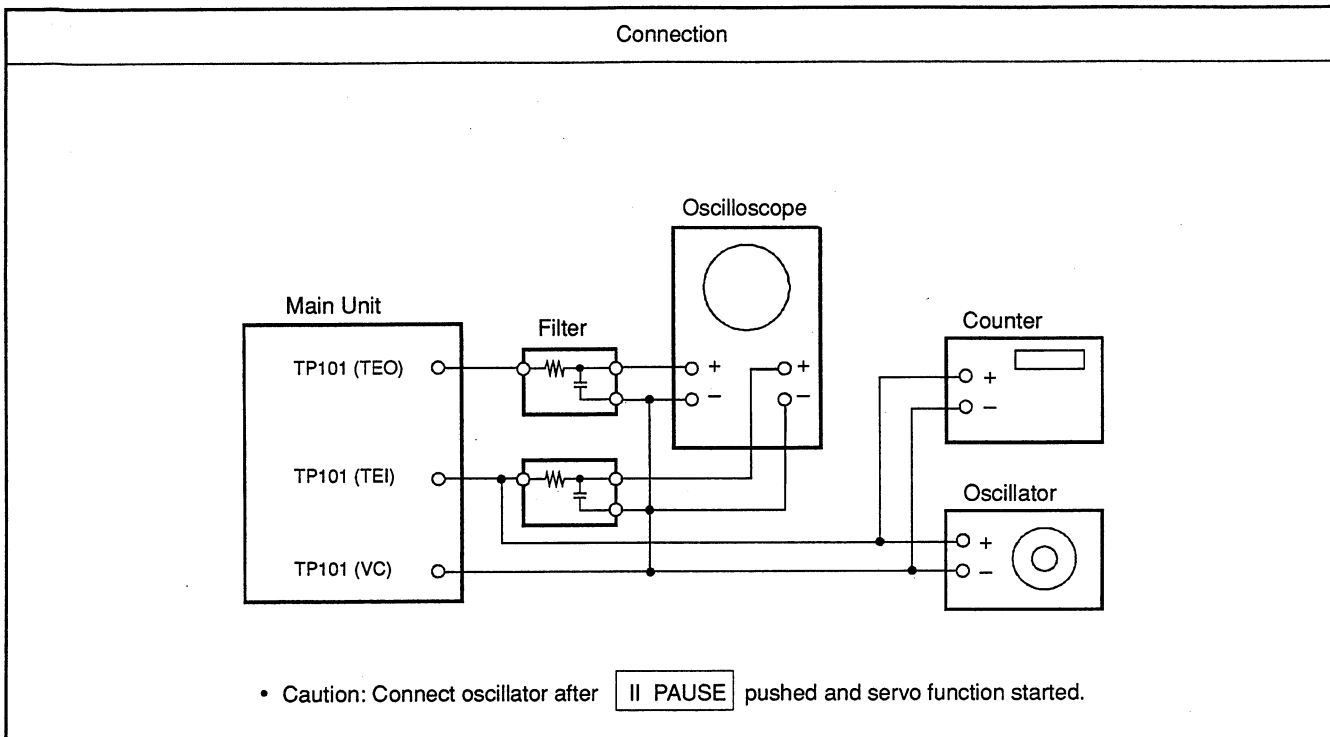

Oscillator	Counter	Oscilloscope		Adjust (Volume)	Check (Oscilloscope)	Step
		V	H			
<ul style="list-style-type: none"> ● 2.7 kHz (±120 Hz) ● 0.8 Vp-p (±0.1V) 	2.7 kHz (±120 Hz)	<ul style="list-style-type: none"> ● DC range ● X-Y mode 	VR104		<ol style="list-style-type: none"> 1. Push II PAUSE (Displays track number 03) 2. Connect oscillator. 3. Set oscillator to 2.7 kHz/0.8 Vp-p. 4. Switch oscilloscope input to X-Y mode. 5. Adjust VR104 [T-GAIN] to symmetrize Lissajous figures to X-Y axes. 	

6. Tracking offset (E/F Balance)

Connection			
Oscilloscope		Check	Step
V	H	(Oscilloscope)	
0.1v/div	1~2 ms/div	$\frac{A-B}{A+B} < 20\%$	<ol style="list-style-type: none"> 1. Push ▲ OPEN/CLOSE and load disc holder reference disk. 2. Push ▲ PEN/CLOSE and close disc holder. 3. Push ▶ PLAY to turn disc. (Displays track number 02) 4. Short (+)(-) of oscilloscope and check the base line. 5. Confirm that upper and lower amplitude of the waveform is symmetric against 0V.

7. HF level

Connection			
<div style="text-align: center;"> </div>			
Oscilloscope		Check	Step
V	H	(Oscilloscope)	
50mv/div or 20mV/div	0.2μV/div or 0.5μV/div	<p style="text-align: center;">$A=1.2+0.3Vp-p$</p>	<ol style="list-style-type: none"> 1. Push II PAUSE. (Displays track number 03) 2. Check HF level of oscilloscope. 3. Confirm that the waveform is in good shape. (◆ pattern in center must be able to discriminate clearly.)
<ul style="list-style-type: none"> • Set input mode to ALTERNATE or CHOPPER. 			

HEAT RUN MODE FUNCTION

Heat Run Mode

1) To activate

While hold pushing ►►, ◀◀, ►► and ◀◀ keys simultaneously, turn the unit power on. The remote control sensor indicator will light to show that the unit is shifted in Heat Run mode.

Be sure to load the disc previously.

Press the disc holder open/close button (▲ OPEN/CLOSE) to cancel Heat Run mode.

★ **This mode functions only for a disc with 21 pieces of music or more. For a disc with 20 pieces of music or lesser, please do not use.**

2) Operation

During the Heat Run mode to shift the unit in Play mode makes the unit replays from the first music after opens the loader once and re-closes it when finish playing the last track (comes into lead out).

Hereafter, operates open/close of loader, servo on, reading of TOC, and playing repeatedly, and repeats playing the two tracks; the first and the last ones.

3) Error Message

When the system error occurs while in Heat Run mode, the following error message will display on the Track No. indicator and stops operation.

1. E1

At the time of Focus Servo does not activate.

2. E2

When unable to detect synchronous pattern however the disc is in rotating. (GFS does not drive.)

3. E3

No synchronous pattern can be detected while in Play mode. (No GFS drives.)

4. E4

When TOC is unreadable in despite of servo is activated.

5. E5

In case of loader malfunctions. (Unable to turn on the switch.)

6. E6

The inner circle switch of Pick-up does not turn off.

7. E7

The inner circle switch of Pick-up does not turn on.

★ The number of operation up to the stop will be displayed on the minute and second portion of the indicator.

IC TERMINAL FUNCTION LIST

CXD2500Q Terminal Function

Terminal No.	Symbol	I/O	Terminal Function
1	FOK	I	Input terminal for OK focussing. Use for Servo-autosequencer.
2	FSW	O	Output to shift time constant of output filter for spindle motor.
3	MON	O	ON/OFF control output for spindle motor.
4	MDP	O	Servo control for spindle motor.
5	MDS	O	Servo control for spindle motor.
6	LOCK	O	Sampling GFS by 460 Hz and if it is "H", delivers "H" ; if it is continuously "L" 8 times, delivers "L".
7	NC	—	
8	VCOO	O	Oscillation current output for analog EFM PLL.
9	VCOI	I	Oscillation current output for analog EFM PLL. f LOCK=8.6436MHz.
10	TEST	I	TEST output. Normally GND.
11	PDO	O	Charge pump output for analog EFM PLL.
12	Vss		GND.
13	NC	—	
14	NC	—	
15	NC	—	
16	VPCO	O	Charge pump output for variable pitch PLL.
17	VCKI	O	Clock input from external VCO for variable pitch. fc center=16.9344MHz.
18	FILO	O	Filter output for master PLL. (slave=digital PLL)
19	FILI	I	Filter input for master PLL.
20	PCO	O	Charge pump output for master PLL.
21	AVss		Analog GND.
22	CLTV	I	Control voltage output for master VCO.
23	AVdd		Analog power supply (+5V).
24	RF	I	EFM signal input.
25	TEST2	I	Put to GND.
26	TEST3	I	Put to GND.
27	ASYO	O	Full swing output for EFM. (L=Vss, H=VDD).
28	TEST4	I	Put to GND.
29	NC	—	
30	PSSL	I	Input to shift output mode of audio data. Serial output at L; parallel output at H.
31	WDCK	O	D/A Interface for 48 bit slot. Word-clock f=2 Fs.
32	LRCK	O	D/A Interface for 48 bit slot. LR-clock f= Fs.
33	Vdd		Power supply (+5V).
34	DA16	O	At PSSL=1 for DA16 (MBS) output; PSSL=0 for serial data of 48 bit slot. (2s'COMP, MSB first).
35	DA15	O	At PSSL=1 for DA15 output; PSSL=0 for bit clock of 48 bit slot.
36	DA14	O	At PSSL=1 for DA14 output; PSSL=0 for serial data of 64 bit slot. (2s'COMP, LSB first).
37	DA13	O	At PSSL=1 for DA13 output; PSSL=0 for bit clock of 64 bit slot.
38	DA12	O	At PSSL=1 for DA12 output; PSSL=0 for LR clock of 64 bit slot.
39	DA11	O	At PSSL=1 for DA11 output; PSSL=0 for GTOP output.
40	DA10	O	At PSSL=1 for DA10 output; PSSL=0 for XUGF output.
41	DA09	O	At PSSL=1 for DA09 output; PSSL=0 for XPLCK output.
42	DA08	O	At PSSL=1 for DA08 output; PSSL=0 for GFS output.
43	DA07	O	At PSSL=1 for DA07 output; PSSL=0 for RFCK output.
44	DA06	O	At PSSL=1 for DA06 output; PSSL=0 for C2PO output.
45	DA05	O	At PSSL=1 for DA05 output; PSSL=0 for XRAOF output.
46	DA04	O	At PSSL=1 for DA04 output; PSSL=0 for MNT3 output.
47	DA03	O	At PSSL=1 for DA03 output; PSSL=0 for MNT2 output.
48	DA02	O	At PSSL=1 for DA02 output; PSSL=0 for MNT1 output.
49	DA01	O	At PSSL=1 for DA01 output; PSSL=0 for MNT0 output.
50	APTR	O	Control output for aperture compensation. In H for R-ch.
51	APTL	O	Control output for aperture compensation. In H for L-ch.

Terminal No.	Symbol	I/O	Terminal Function
52	Vss		GND.
53	XTAI	I	X'tal oscillation circuit input. By selecting of mode, f=16.9344MHz or 33.8688MHz.
54	XTAO	O	X'tal oscillation circuit input. f=16.9344MHz.
55	XTSL	I	Selection input terminal of X'tal. "L" for X'tal 16.9344MHz; H for 33.8688MHz.
56	FSTT	O	2/3 Dividing output of 53 and 54 terminal. No change by variable pitch.
57	C4M	O	4.2336MHz output. When variable pitched, simultaneously changes.
58	C16M	O	16.9344MHz output. When variable pitched, simultaneously changes.
59	MD2	I	Digital-out ON/OFF control. ON at H; OFF at L.
60	DOUT	O	Digital-out output terminal.
61	EMPH	O	When playback disc emphasized, outputs H; otherwise outputs L.
62	WFCK	O	WFCK (Write Flame Clock) output.
63	SCOR	O	Output of subcode sync. S0+S1. H output when either one detected.
64	SBSO	O	Serial output of Sub P~W.
65	EXCK	I	Clock input for SBSO read-out.
66	SQSO	O	Output for Sub Q 80 bits and PCM peak level 16 bits.
67	SQCK	I	Clock input for SQSO read-out.
68	MUTE	I	Mute at H; remove mute at L.
69	SENS	—	SENS output. Outputs to CPU.
70	XRST	I	System reset input. Resets at "L".
71	DATA	I	Input of serial data from CPU.
72	XLAT	I	Input for latch from CPU. Latches serial data at release.
73	VDD		Power supply (+5V).
74	CLOCK	I	Serial data transfer clock input from CPU.
75	SEIN	I	SENS input from SSP.
76	CNIN	I	Input of tracking pulse.
77	DATO	O	Serial data output to SSP.
78	XLTO	O	Serial data latch output to SSP.
79	CLKO	O	Serial data transfer clock output to SSP.
80	MIRR	I	Mirror signal input. Use for track jump for over 128 tracks, using autosequencer.

CXD2500Q

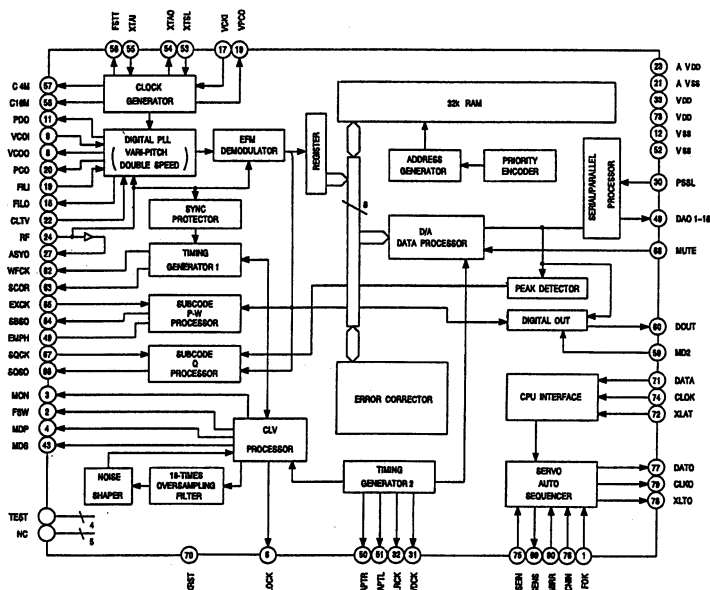

CXA1372S Terminal Function

Terminal No.	Symbol	I/O	Terminal Function
1	TE	I	Tracking error signal input terminal.
2	TDFCT	I	Capacitor connecting terminal for time constant at the time of defect.
3	ATSC	I	Input terminal of ATSC detecting window comparator.
4	FZC	I	Input terminal of focus zero-cross comparator.
5	FE	I	Focus error signal input terminal.
6	FDFCT	I	Capacitor connecting terminal for time constant at the time of defect.
7	Vc	I	Mid-point voltage input terminal.
8	FGD	I	In case of reducing higher range gain of focus servo, connect a capacitor between this terminal and terminal number (9).
9	FS3	I	Shifts higher range gain of focus servo by FS3 ON/OFF.
10	FLB	I	Terminal for external time constant to increase lower range of focus servo.
11	FEO	O	Focus drive output.
12	FE-	I	Reverse input terminal for focus amplifier.
13	SRCH	I	Terminal for external time constant to make focus search waveform.
14	TGU	I	Terminal for external time constant to shift higher range gain of tracking.
15	TG2	I	Terminal for external time constant to shift higher range gain of tracking.
17	TAO	O	Tracking drive output.
18	TA-	I	Reverse input terminal for tracking amplifier.
19	SL+	I	Non-reverse input terminal for sled amplifier.
20	SLO	O	Sled drive output.
21	SL-	I	Reverse input terminal for sled amplifier.
22	FSET	I	Terminal to compensate peak in focus/tracking phase.
23	ISET	I	Delivers a current to set the height of focus search, track jump, and sled kick.
24	SSTOP	I	Terminal for limit switch ON/OFF to detect disc innermost circle.
26	DIRC	I	Terminal is used at the time of 1 track jump. A 47 kohm pull up resistor is included.
27	LOCK	I	Reckless drive protection circuit of sled; activates at "L". A 47k ohm pull up resistor is included.
28	CLK	I	Serial data transfer clock input from CPU.
29	XLT	I	Latch input from CPU.
30	DATA	I	Serial data input from CPU.
31	XRST	I	Reset input terminal. Resets at "L".
32	C.OUT	O	Terminal to output signal for track number count.
33	SENS	O	Terminal to output FZC, AS, TZC, SSTOP by command from CPU.
35	MIRR	O	Output terminal for MIRR comparator.
36	DFCT	O	Output terminal for DEFECT comparator.
37	ASY	I	Input terminal for auto-symmetric control.
38	EFM	O	Output terminal for EFM comparator.
39	FOK	O	Output terminal for focus OK (FOK) comparator.
40	CC1	O	DEFECT bottom hold output terminal.
41	CC2	I	Input terminal to input DEFECT bottom hold output by capacitance combination.
43	CB	I	Capacitor connecting terminal for DEFECT bottom hold.
44	CP	I	MIRR hold capacitor connecting terminal. A non-reverse input terminal for MIRR comparator.
45	RF1	I	Input terminal to input RF summing amplifier output by capacitance combination.
46	RFO	O	Output terminal for RF summing amplifier. Check point for eye pattern.
48	TZC	I	Tracking zero-cross comparator input terminal.

CXA1372S

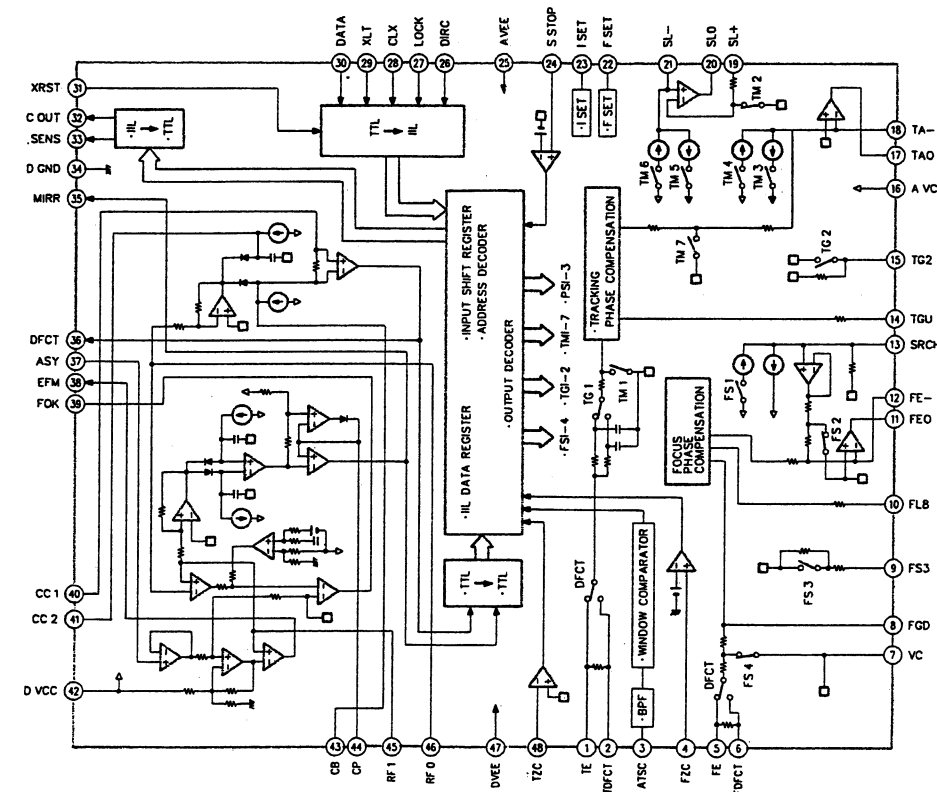

HG62E33R79FS Terminal Function

Terminal No.	Symbol	I/O	Terminal Function
1	DGIN-L	I	Lch DG input.
2	DGIN-R	I	Rch DG input.
3	SDIN-L	I	Lch DATA input.
4	SDIN	I	Rch DATA input.
5	WCKIN-L	I	Lch WCK input.
6	WCKIN-R	I	Rch WCK input.
7	BCKIN-L	I	Lch BCK input.
8	BCKIN-R	I	Rch BCK input.
9	(GND)	I	—
10	(GND)	I	—
11	(GND)	I	—
12	(GND)	I	—
13	CLR-L	I	Lch reset input.
14	CLR-R	I	Rch reset input.
15	NC	—	—
16	NC	—	—
17	NC	—	—
18	NC	—	—
19	NC	—	—
20	BCKO-L1	O	Lch BCK output.
21	WCK1-L1	O	Lch WCK output at S18-L use.
22	S01-L	O	Lch 20 bit DATA (± 9 bit) output.
23	S18-L	O	Lch 18 bit DATA output (± 9 bit alternate output).
24	S19-L	O	Lch 19 bit parallel output (for current adding).
25	S20-L	O	Lch 20 bit parallel output (for current adding).
26	(Vcc)	I	—
27	WCKOUT-L	O	Lch WCK reverse output.
28	WCK2-L	O	Lch current adding output for ± 9 bit compensation at S18-L use.
29	BCKO-L2	O	Lch BCK output. Same as Pin 20.
30	WCK1-L2	O	Lch WCK output at S18-L use. Same as Pin 21.
31	S02-L	O	Lch 20 bit DATA (± 9 bit) output.
32	(GND)	I	—
33	SH-01L	O	Lch DG output.
34	SH-02L	O	Lch DG reverse output.
35	OVER-L	O	Lch current adding output at OVER.
36	NC	—	—
37	RCKO-R1	O	Rch BCK output.
38	WCK1-R1	O	Rch WCK output at S18-R use.
39	S01-R	O	Rch 20 bit DATA (± 9 bit) output.
40	S18-R	O	Rch 18 bit DATA output (± 9 bit alternate output).
41	P19-R	O	Rch 19 bit parallel output (for current adding).
42	(GND)	I	—
43	P20-R	O	Rch 20 bit parallel output (for current adding).
44	WCKOUT-R	O	Rch WCK reverse output.
45	WCK2-R	O	Rch current adding output for ± 9 bit compensation at S-18R use.
46	RCKO-R2	O	Rch BCK output. Same as Pin 37.
47	WCK1-R2	O	Rch WCK output at S18-R use. Same as Pin 33.
48	S02-R	O	Rch 20 bit DATA (± 9 bit) output.
49	SH01-R	O	Rch DG output.
50	SH02-R	O	Rch DG reverse output.
51	OVER-R	O	Rch current adding output at OVER.

Terminal No.	Symbol	I/O	Terminal Function
52	INVD1-L	I	Lch reversal of MSB input (off set binary: L) (complement of 2: H).
53	INVD1-R	I	Rch reversal of MSB input (off set binary: L) (complement of 2: H).
54	INV1-L	I	Lch reversal of input DATA (reverse at H).
55	INV1-R	I	Rch reversal of input DATA (reverse at H).
56	INV2-L	I	Lch whole reversal of S02 output (reverse at H).
57	INV2-R	I	Rch whole reversal of S02 output (reverse at H).
58	(Vcc)	I	—
59	SA1-L	I	Refer to the note below:
60	SA1-R	I	Refer to the note below:
61	SA2-L	I	Refer to the note below:
62	SA2-R	I	Refer to the note below:
63	(GND)	I	—
64	(GND)	I	—

Note: About SA1, SA2 for both Lch and Rch.
 ● SA1 at L, SA2 at H S01: +9 bit, S02: -9 bit
 ● SA1 at H, SA2 at L S01: -9 bit, S02: +9 bit

Remarks: Every Vcc and GND pins should be connected to the system's Vcc, GND.

NOTE FOR PARTS LIST

- Part indicated with the mark "◎" are not always in stock and possibly to take a long period of time for supplying, or in some case supplying of part may be refused.
- When ordering of part, clearly indicate "1" and "I" (i) to avoid mis-supplying.
- Ordering part without stating its part number can not be supplied.
- Part indicated with the mark "★" is not illustrated in the exploded view.
- Not including Carbon Film ±5%, 1/4W Type in the P.W.Board parts list. (Refer to the Schematic Diagram for those parts.)

WARNING:

Parts marked with this symbol have critical characteristics. Use ONLY replacement parts recommended by the manufacturer.

● Resistors

Ex.: RN 14K 2E 182 G FR
 Type Shape and performance Power Resistance Allowable error Others

RD : Carbon	2B : 1/8W	F : ±1%	P : Pulse-resistant type
RC : Composition	2E : 1/4W	G : ±2%	NL : Low noise type
RS : Metallic film	2H : 1/2W	J : ±5%	NB : Non-burning type
RW : Winding	3A : 1W	K : ±10%	FR : Fuse-resistor
RN : Metal film	3D : 2W	M : ±20%	F : Lead wire forming
RK : Metal mixture	3F : 3W		
	3H : 5W		

Resistance

1 8 2 ⇒ 1800 ohm = 1.8 kohm
 Indicates number of zeros after effective number
 2-digit effective number, decimal point indicated by R.
 • Units: ohm

● Capacitors

Ex.: CE 04W 1H 2R2 M BP
 Type Shape and performance Dielectric strength Capacity Allowable error Others

CE : Aluminum foil electrolytic	0J : 6.3V	F : ±1%	HS : High stability type
CA : Aluminum solid electrolytic	1A : 10V	G : ±2%	BP : Non-polar type
CS : Tantalum electrolytic	1C : 16V	J : ±5%	HR : Ripple-resistant type
CQ : Film	1E : 25V	K : ±10%	DL : For charge and discharge
CK : Ceramic	1V : 35V	M : ±20%	HF : For assuring high frequency
CC : Ceramic	1H : 50V	Z : +80%	U : UL part
CP : Oil	2A : 100V	-20%	C : CSA part
CM : Mica	2B : 125V	P : +100%	W : UL-CSA type
CF : Metallized	2C : 160V	-0%	F : Lead wire forming
CH : Metallized	2D : 200V	C : ±0.25pF	
	2E : 250V	D : ±0.5pF	
	2H : 500V	= : Others	
	2J : 630V		

Capacity

2 R 2 ⇒ 2.2µF
 1-digit effective number, decimal point indicated by R.
 2-digit effective number, decimal point indicated by R.

- Units: µF, (for P, pF (µµF))
- When the dielectric strength is indicated in AC, "AC" is included after the dielectricUnits: µF, (for P, pF (µµF))

PARTS LIST OF P.W. BOARD

3U-2455 MAIN UNIT (DCD-1290)
[U.S.A., Canada and Australia Models]

Ref.No	Part .No	Part Name	Remarks
SEMICONDUCTORS GROUP			
IC ?	263 0652 907	IC PST529C	
IC102	262 1305 001	IC CXA1372S	
IC103-106	263 0565 007	IC BA15218	
IC201	262 1471 003	IC M50959-359SP	
IC202	262 1514 009	IC CXD2500AQ	
IC203	262 0824 004	IC SN74LS624N	
IC204	262 1352 009	IC TC74HCT04AP	
IC300	262 1306 000	IC SM5840AP	
IC301	262 1616 004	IC HG62E33R79FS	
IC303,304	262 1171 002	IC PCM61P	
IC309,310	262 0864 004	IC UPC4570C	
IC502,503	268 0073 905	IC Protector ICP-N15T	
IC506	263 0683 002	IC NJM7906FA	
IC ?	263 0793 002	IC NJM7806FA(S)	
IC701	262 1265 002	IC TC74HCU04AP	
IC702,703	262 0864 004	IC UPC4570C	
IC704	262 0640 000	IC MN6632A	
IC705	263 0198 005	IC NJM4556D	
TR101	269 0020 906	Digital Tr. DTC114ES(10K-10K)T	
TR109	274 0036 905	Transistor 2SD468(C)TF	
TR110	272 0025 907	Transistor 2SB562(C)TF	
TR111	274 0036 905	Transistor 2SD468(C)TF	
TR112	272 0025 907	Transistor 2SB562(C)TF	
TR113	274 0036 905	Transistor 2SD468(C)TF	
TR114	272 0025 907	Transistor 2SB562(C)TF	
TR115	274 0136 009	Transistor 2SD1913	
TR116	272 0025 907	Transistor 2SB562(C)TF	
TR117	274 0036 905	Transistor 2SD468(C)TF	
TR118	272 0025 907	Transistor 2SB562(C)TF	
TR503	271 0101 925	Transistor 2SA933(Q)T-70	
TR600,601	274 0124 901	Transistor 2SD1504(E/F)	
TR701	271 0102 908	Transistor 2SA1015(Y)	
TR702	269 0014 909	Digital Tr. DTA124XS(22K-47K)T	
TR703	269 0020 906	Digital Tr. DTC114ES(10K-10K)T	
TR713	274 0124 901	Transistor 2SD1504(E/F)	
TR715	274 0124 901	Transistor 2SD1504(E/F)	
TR717	274 0124 901	Transistor 2SD1504(E/F)	
TR719	274 0124 901	Transistor 2SD1504(E/F)	
D201-204	276 0432 903	Diode 1SS270A TE	
D501-506	276 0553 905	Diode 1SR35-200A(T93X)	
D515	276 0484 919	Zener Diode HZS33-2TD	
D516	276 0465 912	Zener Diode HZS7B-2TD	
D601-608	276 0432 903	Diode 1SS270A TE	
D701	276 0432 903	Diode 1SS270A TE	
D703	276 0432 903	Diode 1SS270A TE	
RESISTORS GROUP			
(Not included Carbon film *5%, 1/4W Type)			
VR102-104	211 6077 954	Adjust 22K ohm	V06PB223(IM)
VR300,301	211 6077 938	Adjust 100K ohm	V06PB104(IM)
VR601	211 0764 001	Variable 20K ohm	V0920FA203

Ref.No	Part .No	Part Name	Remarks
CAPACITORS GROUP			
C106	255 1206 908	Film 0.0033μ/50V	CQ93M1H332JT
C107	256 1034 908	Metallized 0.027μ/50V	CF93A1H273JT
C108	255 1204 900	Film 0.0022μ/50V	CQ93M1H222JT
C109-112	256 1034 979	Metallized 0.1μ/50V	CF93A1H104JT
C113	254 4337 910	Electrolytic 6.8μ/50V	CE04W1H6R8MT
C114	256 1035 910	Metallized 0.22μ/50V	CF93A1H224JT
C116	255 1212 905	Film 0.01μ/50V	CQ93M1H103JT
C117	253 9039 906	Ceramic 0.1μ/25V	CK45=1E104ZT
C118,119	253 1180 921	Ceramic 0.001μ/50V	CK45B1H102KT
C120	253 9039 906	Ceramic 0.1μ/25V	CK45=1E104ZT
C121	253 1181 904	Ceramic 0.01μ/50V	CK45F1H103ZT
C122,123	254 4260 919	Electrolytic 0.22μ/50V	CE04W1HR22MT
C124	255 1212 905	Film 0.01μ/50V	CQ93M1H103JT
C125	256 1034 911	Metallized 0.033μ/50V	CF93A1H333JT
C126	255 1212 905	Film 0.01μ/50V	CQ93M1H103JT
C127	255 1206 908	Film 0.0033μ/50V	CQ93M1H332JT
C128	255 1205 909	Film 0.0027μ/50V	CQ93M1H272JT
C129	253 9039 906	Ceramic 0.1μ/25V	CK45=1E104ZT
C130	253 1179 990	Ceramic 560p/50V	CK45B1H561KT
C131	255 1209 905	Film 0.0056μ/50V	CQ93M1H562JT
C132	253 4538 910	Ceramic 75p/50V	CC45SL1H750JT
C133	253 4536 909	Ceramic 10p/50V	CC45SL1H100DT
C134	256 1034 979	Metallized 0.1μ/50V	CF93A1H104JT
C135	254 3055 918	Electrolytic 10μ/35V Bipolar	CE04D1V100MBPT
C136	253 4538 949	Ceramic 100p/50V	CC45SL1H101JT
C137,138	254 4260 964	Electrolytic 3.3μ/50V	CE04W1H3R3MT
C140	255 1212 905	Film 0.01μ/50V	CQ93M1H103JT
C141	253 4538 949	Ceramic 100p/50V	CC45SL1H101JT
C142	253 9039 906	Ceramic 0.1μ/25V	CK45=1E104ZT
C143	253 1180 921	Ceramic 0.001μ/50V	CK45B1H102KT
C164	253 4536 941	Ceramic 15p/50V	CC45SL1H150JT
C166	253 4536 941	Ceramic 15p/50V	CC45SL1H150JT
C168	253 4538 910	Ceramic 75p/50V	CC45SL1H750JT
C170,171	254 4254 938	Electrolytic 47μ/16V	CE04W1C470MT
C173	254 4254 938	Electrolytic 47μ/16V	CE04W1C470MT
C174	253 9039 906	Ceramic 0.1μ/25V	CK45=1E104ZT
C201	253 9039 906	Ceramic 0.1μ/25V	CK45=1E104ZT
C202,203	253 1181 904	Ceramic 0.01μ/50V	CK45F1H103ZT
C210	256 1034 937	Metallized 0.047μ/50V	CF93A1H473JT
C211	253 1180 947	Ceramic 0.0015μ/50V	CK45B1H152KT
C212,213	253 9039 906	Ceramic 0.1μ/25V	CK45=1E104ZT
C212,213	253 1179 987	Ceramic 470p/50V	CK45B1H471KT
C214	254 4250 932	Electrolytic 220μ/6.3V	CE04W0J221MT
C220	254 4260 922	Electrolytic 0.33μ/50V	CE04W1HR33MT
C222	253 4537 937	Ceramic 36p/50V	CC45SL1H360JT
C223	253 4535 939	Ceramic 3p/50V	CC45SL1H030CT
C224	253 4535 955	Ceramic 5p/50V	CC45SL1H050CT
C301	253 1179 961	Ceramic 330p/50V	CK45B1H331KT
C305,306	253 1179 932	Ceramic 180p/50V	CK45B1H181KT
C307,308	253 1180 918	Ceramic 820p/50V	CK45B1H821KT
C311,312	253 1180 921	Ceramic 0.001μ/50V	CK45B1H102KT
C313	253 4443 908	Ceramic 200p/50V	CC45SL1H201JT
C317	253 9039 906	Ceramic 0.1μ/25V	CK45=1E104ZT
C318	254 4254 925	Electrolytic 33μ/16V	CE04W1C330MT
C321,322	253 9039 906	Ceramic 0.1μ/25V	CK45=1E104ZT
C327	254 4250 929	Electrolytic 100μ/6.3V	CE04W0J101MT

3U-2431 MAIN UNIT (DCD-1290)
[Europe and U.K. Models]

Ref.No	Part .No	Part Name	Remarks
C328-331	254 4356 713	Electrolytic 100μ/50V	CE04W1H101MC
C501,502	254 4313 727	Electrolytic 2200μ/50V	CE04W1H222MC
C507	254 4262 946	Electrolytic 47μ/63V	CE04W1J470MT
C508	254 4261 921	Electrolytic 100μ/50V	CE04W1H101MT
C509,510	254 4261 905	Electrolytic 33μ/50V	CE04W1H330MT
C514	253 9039 906	Ceramic 0.1μ/25V	CK45=1E104ZT
C600,601	253 1181 904	Ceramic 0.01μ/50V	CK45F1H103ZT
C602,603	253 1181 904	Ceramic 0.01μ/50V	CK45F1H103ZT
C701	253 9039 906	Ceramic 0.1μ/25V	CK45=1E104ZT
C701	254 4260 977	Electrolytic 4.7μ/50V	CE04W1H4R7MT
C703	253 4443 908	Ceramic 200p/50V	CC45SL1H201JT
C704	254 4254 954	Electrolytic 220μ/16V	CE04W1C221MT
C705,706	253 4537 982	Ceramic 56p/50V	CC45SL1H560JT
C707,708	254 4254 941	Electrolytic 100μ/16V	CE04W1C101MT
C708,709	253 4537 924	Ceramic 33p/50V	CC45SL1H330JT
C714,715	254 4254 909	Electrolytic 10μ/16V	CE04W1C100MT
C718,719	254 4250 929	Electrolytic 100μ/6.3V	CE04W0J101MT
C731	253 4538 949	Ceramic 100p/50V	CC45SL1H101JT
C800-803	253 1180 921	Ceramic 0.001μ/50V	CK45B1H102KT
C804	253 4538 949	Ceramic 100p/50V	CC45SL1H101JT
C805	253 1181 904	Ceramic 0.01μ/50V	CK45F1H103ZT
C806	253 4536 983	Ceramic 22p/50V	CC45SL1H220JT
C807	253 9039 906	Ceramic 0.1μ/25V	CK45=1E104ZT
C807,808	253 9039 906	Ceramic 0.1μ/25V	CK45=1E104ZT
OTHER PARTS			
X200	399 0165 007	Crystal Oscillator	16.9344MHz
X201	399 0111 006	Ceramic Oscillator	CST4.23MGW040
RM601	499 0150 008	REMOTE SENSOR	SBX1610-52
PT300	231 8063 009	PULSE TRANS	
JK	204 8322 007	HEAD PHONE JACK	
JK701	204 8256 005	1P PIN JACK	(DIGITAL OUT)
JK	204 8261 003	4P PIN JACK	(FIX-VARI. OUT)
U701	269 0096 008	OPTICAL CONN.	(OPTICAL OUT)
LCD601	393 4095 007	FL TUBE	FIP10SM6
CB101	205 0321 054	5P CONNECTOR BASE(RED)	
CB102	205 0343 058	5P CONNECTOR BASE(KR-PH)	
CB103	205 0683 006	FFC CONNECTOR BASE(12P)	
CB203	205 0549 001	31P FFC CONNECTOR BASE	
CB500	205 0343 061	6P CONNECTOR BASE(KR-PH)	
CB601	205 0549 001	31P FFC CONNECTOR BASE	
CB602	205 0343 045	4P CONNECTOR BASE(KR-PH)	
TP101,102	205 0190 065	6P MH CONNECTOR BASE	

Ref.No	Part .No	Part Name	Remarks
SEMICONDUCTORS GROUP			
IC102	262 1305 001	IC CXA1372S	
IC103-106	263 0712 009	IC RC4558P	
◆	263 0565 007	IC BA15218	
IC201	262 1652 000	IC M50959-383SP	
IC202	262 1514 009	IC CXD2500AQ	
IC203	262 0824 004	IC SN74LS624N	
IC204	262 1617 003	IC SN74HCT04N	
◆	262 1352 009	IC TC74HCT04AP	
IC205	263 0652 907	IC PST529C	
IC300	262 1306 000	IC SM5840AP	
IC301	262 1616 004	IC HG62E33R79FS	
IC303,304	262 1171 002	IC PCM61P	
IC309,310	262 0864 006	IC UPC4570C	
IC501	263 0809 006	IC NJM7805FA(S)	
IC502,503	268 0073 905	IC Protector	ICP-N15T
IC506	263 0683 002	IC NJM7906FA	
IC507	263 0792 003	IC NJM78M06FA(S)	
IC701	262 1618 002	IC SN74HCU04N	
◆	262 1265 002	IC TC74HCU04AP	
IC702,703	262 0864 006	IC UPC4570C	
IC704	262 0640 000	IC MN6632A	
IC705	263 0198 005	IC NJM4556D	
TR101	269 0020 906	Digital Tr. DTC114ES(10K-10K)T	
TR109	274 0144 907	Transistor :BC368	
◆	274 0036 905	Transistor 2SD468(C)TF	
TR110	272 0101 902	Transistor :BC369	
◆	272 0025 907	Transistor 2SB562(C)TF	
TR111	274 0144 907	Transistor :BC368	
◆	274 0036 905	Transistor 2SD468(C)TF	
TR112	272 0101 902	Transistor :BC369	
◆	272 0025 907	Transistor 2SB562(C)TF	
TR113	274 0144 907	Transistor :BC368	
◆	274 0036 905	Transistor 2SD468(C)TF	
TR114	272 0101 902	Transistor :BC369	
◆	272 0025 907	Transistor 2SB562(C)TF	
TR115	274 0145 003	Transistor :BD935F	
◆	274 0136 009	Transistor 2SD1913	
TR116	272 0101 902	Transistor :BC369	
◆	272 0025 907	Transistor 2SB562(C)TF	
TR117	274 0144 907	Transistor :BC368	
◆	274 0036 905	Transistor 2SD468(C)TF	
TR118	272 0101 902	Transistor :BC369	
◆	272 0025 907	Transistor 2SB562(C)TF	
TR503	271 0387 901	Transistor :JC557(A/B)	
◆	271 0101 925	Transistor 2SA933(Q)T-70	

3U-2455A MAIN UNIT (DCD-2060G/2060)
[Multi-Voltage (Asia) Model]

Ref.No	Part .No	Part Name	Remarks
D505-510	276 0553 905	Diode 1SR35-200A(T93X)	
D515	276 0484 919	Zener Diode HZS33-2TD	
D516	276 0465 912	Zener Diode HZS7B-2TD	
D601-608	276 0432 903	Diode 1SS270A TE	
D701	276 0432 903	Diode 1SS270A TE	
D703	276 0432 903	Diode 1SS270A TE	
D900	276 0460 904	Zener Diode HZS5C-1TD	
RESISTORS GROUP			
(Not included Carbon film ±5% ,1/4W Type)			
VR102,104	211 6087 915	Adjust 22K ohm	V06PB223T
VR300,301	211 6087 928	Adjust 100K ohm	V06PB104T
VR601	211 0764 001	Variable 20K ohm	V0920FA203
CAPACITORS GROUP			
C106	255 1206 908	Film 0.0033μ/50V	CQ93M1H332JT
C107	256 1034 937	Metallized 0.047μ/50V	CF93A1H473JT
C108	255 1204 900	Film 0.0022μ/50V	CQ93M1H222JT
C109-112	256 1034 979	Metallized 0.1μ/50V	CF93A1H104JT
C113	254 4337 910	Electrolytic 6.8μ/50V	CE04W1H6R8MT
C114	256 1035 910	Metallized 0.22μ/50V	CF93A1H224JT
C116	255 1212 905	Film 0.01μ/50V	CQ93M1H103JT
C117	253 9039 906	Ceramic 0.1μ/25V	CK45=1E104ZT
C118,119	253 1180 921	Ceramic 0.001μ/50V	CK45B1H102KT
C120	253 9039 906	Ceramic 0.1μ/25V	CK45=1E104ZT
C121	253 1181 904	Ceramic 0.01μ/50V	CK45F1H103ZT
C122,123	254 4260 919	Electrolytic 0.22μ/50V	CE04W1HR22MT
C124	255 1212 905	Film 0.01μ/50V	CQ93M1H103JT
C125	256 1034 911	Metallized 0.033μ/50V	CF93A1H333JT
C126	255 1212 905	Film 0.01μ/50V	CQ93M1H103JT
C127	255 1206 908	Film 0.0033μ/50V	CQ93M1H332JT
C128	255 1205 909	Film 0.0027μ/50V	CQ93M1H272JT
C129	253 9039 906	Ceramic 0.1μ/25V	CK45=1E104ZT
C130	253 1179 990	Ceramic 560p/50V	CK45B1H561KT
C131	255 1209 905	Film 0.0056μ/50V	CQ93M1H562JT
C132	253 4538 910	Ceramic 75p/50V	CC45SL1H750JT
C133	253 4536 909	Ceramic 10p/50V	CC45SL1H100DT
C134	256 1034 979	Metallized 0.1μ/50V	CF93A1H104JT
C135	254 3055 918	Electrolytic 10μ/35V Bipolar	CE04D1V100MBPT
C136	253 4538 949	Ceramic 100p/50V	CC45SL1H101JT
C140	255 1212 905	Film 0.01μ/50V	CQ93M1H103JT
C141	253 4538 949	Ceramic 100p/50V	CC45SL1H101JT
C142	253 9039 906	Ceramic 0.1μ/25V	CK45=1E104ZT
C160-163	253 1180 921	Ceramic 0.001μ/50V	CK45B1H102KT
C164	253 4536 941	Ceramic 15p/50V	CC45SL1H150JT
C166	253 4536 941	Ceramic 15p/50V	CC45SL1H150JT
C168	253 4538 910	Ceramic 75p/50V	CC45SL1H750JT
C170,171	254 4254 938	Electrolytic 47μ/16V	CE04W1C470MT
C173	254 4254 938	Electrolytic 47μ/16V	CE04W1C470MT
C174	253 9039 906	Ceramic 0.1μ/25V	CK45=1E104ZT
C201	253 9039 906	Ceramic 0.1μ/25V	CK45=1E104ZT
C202,203	253 1181 904	Ceramic 0.01μ/50V	CK45F1H103ZT
C210	256 1034 937	Metallized 0.047μ/50V	CF93A1H473JT

Ref.No	Part .No	Part Name	Remarks
C211	253 1180 947	Ceramic 0.0015μ/50V	CK45B1H152KT
C212,213	253 1179 987	Ceramic 470p/50V	CK45B1H471KT
C214	254 4250 932	Electrolytic 220μ/6.3V	CE04W0J221MT
C215,216	253 9039 906	Ceramic 0.1μ/25V	CK45=1E104ZT
C220	254 4260 922	Electrolytic 0.33μ/50V	CE04W1HR33MT
C222	253 4537 937	Ceramic 36p/50V	CC45SL1H360JT
C223	253 4535 939	Ceramic 3p/50V	CC45SL1H030CT
C224	253 4535 955	Ceramic 5p/50V	CC45SL1H050CT
C301	253 1179 961	Ceramic 330p/50V	CK45B1H331KT
C305,306	253 1179 932	Ceramic 180p/50V	CK45B1H181KT
C307,308	253 1180 918	Ceramic 820p/50V	CK45B1H821KT
C311,312	253 1180 921	Ceramic 0.001μ/50V	CK45B1H102KT
C313	253 4443 908	Ceramic 200p/50V	CC45SL1H201JT
C317	253 9039 906	Ceramic 0.1μ/25V	CK45=1E104ZT
C318	254 4254 925	Electrolytic 33μ/16V	CE04W1C330MT
C321,322	253 9039 906	Ceramic 0.1μ/25V	CK45=1E104ZT
C328-331	254 4356 713	Electrolytic 100μ/50V	CE04W1H101MC
C501,502	254 4313 727	Electrolytic 2200μ/50V	CE04W1H222MC
C507	254 4262 946	Electrolytic 47μ/63V	CE04W1J470MT
C508	254 4261 921	Electrolytic 100μ/50V	CE04W1H101MT
C509,510	254 4260 948	Electrolytic 1μ/50V	CE04W1H010MT
C513	254 4254 954	Electrolytic 220μ/16V	CE04W1C221MT
C514	253 9039 906	Ceramic 0.1μ/25V	CK45=1E104ZT
C602,603	253 1181 904	Ceramic 0.01μ/50V	CK45F1H103ZT
C703	253 4443 908	Ceramic 200p/50V	CC45SL1H201JT
C704	254 4254 954	Electrolytic 220μ/16V	CE04W1C221MT
C705,706	253 4537 982	Ceramic 56p/50V	CC45SL1H560JT
C707,708	254 4254 941	Electrolytic 100μ/16V	CE04W1C101MT
C708,709	253 4537 924	Ceramic 33p/50V	CC45SL1H330JT
C712,713	254 4387 708	Electrolytic 470μ/50V	CE04W1H471M
C714,715	254 4254 909	Electrolytic 10μ/16V	CE04W1C100MT
C716-723	254 4387 708	Electrolytic 470μ/50V	CE04W1H471M
C	254 4256 787	Electrolytic 1000μ/25V	CE04W1E102MC
C731	253 4538 949	Ceramic 100p/50V	CC45SL1H101JT
C800-803	253 1180 921	Ceramic 0.001μ/50V	CK45B1H102KT
C806	253 4536 983	Ceramic 22p/50V	CC45SL1H220JT
C807	253 9039 906	Ceramic 0.1μ/25V	CK45=1E104ZT
C807	253 9039 906	Ceramic 0.1μ/25V	CK45=1E104ZT
OTHER PARTS			
X200	399 0112 005	Crystal Oscillator	16.9344MHz
◆	399 0165 007	Crystal Oscillator	16.9344MHz
X201	399 0111 006	Ceramic Oscillator	CST4.23MGW040
RM601	499 0150 008	REMOTE SENSOR	SBX1610-52
PT300	231 8063 009	PULSE TRANS	
JK	204 8322 007	HEAD PHONE JACK	
JK701	204 8256 005	1P PIN JACK	(DIGITAL OUT)
JK	204 8261 003	4P PIN JACK	(FIX-VARI. OUT)
U701	269 0096 008	OPTICAL CONN.	(OPTICAL OUT)
LCD601	393 4095 007	FL TUBE	FIP10SM6
CB101	205 0321 054	5P CONNECTOR BASE(RED)	
CB102	205 0343 058	5P CONNECTOR BASE(KR-PH)	
CB103	205 0683 006	FFC CONNECTOR BASE(12P)	
CB203	205 0549 001	31P FFC CONNECTOR BASE	

Ref.No	Part .No	Part Name	Remarks
CB300	205 0343 061	6P CONNECTOR BASE(KR-PH)	
CB500	205 0343 061	6P CONNECTOR BASE(KR-PH)	
CB601	205 0549 001	31P FFC CONNECTOR BASE	
TP101,102	205 0190 065	6P MH CONNECTOR BASE	

Ref.No	Part .No	Part Name	Remarks
SEMICONDUCTORS GROUP			
IC102	262 1305 001	IC CXA1372S	
IC103-106	263 0565 007	IC BA15218	
IC201	262 1471 003	IC M50959-359SP	
IC202	262 1514 009	IC CXD2500AQ	
IC203	262 0824 004	IC SN74LS624N	
IC204	262 1352 009	IC TC74HCT04AP	
IC205	263 0652 907	IC PST529C	
IC300	262 1306 000	IC SM5840AP	
IC301	262 1616 004	IC HG62E33R79FS	
IC303,304	262 1663 002	IC AD1861N-J	
IC309,310	262 0864 004	IC μPC4570C	
IC502,503	268 0073 905	IC Protector ICP-N15T	
IC506	263 0539 004	IC NJM79M12FA	
IC507	263 0516 001	IC NJM7812FA	
IC701	262 1265 002	IC TC74HCU04AP	
IC702,703	262 0864 004	IC μPC4570C	
IC704	262 0640 000	IC MN6632A	
IC705	263 0198 005	IC NJM4556D	
TR101	269 0020 906	Digital Tr. DTC114ES(10K-10K)T	
TR109	274 0036 905	Transistor 2SD468(C)TF	
TR110	272 0025 907	Transistor 2SB562(C)TF	
TR111	274 0036 905	Transistor 2SD468(C)TF	
TR112	272 0025 907	Transistor 2SB562(C)TF	
TR113	274 0036 905	Transistor 2SD468(C)TF	
TR114	272 0025 907	Transistor 2SB562(C)TF	
TR115	274 0136 009	Transistor 2SD1913	
TR116	272 0025 907	Transistor 2SB562(C)TF	
TR117	274 0036 905	Transistor 2SD468(C)TF	
TR118	272 0025 907	Transistor 2SB562(C)TF	
TR503	271 0101 925	Transistor 2SA933(Q)T-70	
TR600,601	273 0253 918	Transistor 2SC2878(A/B)	
TR701	271 0102 908	Transistor 2SA1015(Y)	
TR702	269 0014 909	Digital Tr. DTA124XS(22K-47K)T	
TR703	269 0020 906	Digital Tr. DTC114ES(10K-10K)T	
TR713-720	273 0253 918	Transistor 2SC2878(A/B)	
D201-204	276 0432 903	Diode 1SS270A TE	
D501-514	276 0553 905	Diode 1SR35-200A(T93X)	
D515	276 0484 919	Zener Diode HZS33-2TD	
D516	276 0465 912	Zener Diode HZS7B-2TD	
D601-608	276 0432 903	Diode 1SS270A TE	
D701	276 0432 903	Diode 1SS270A TE	
D703	276 0432 903	Diode 1SS270A TE	
RESISTORS GROUP			
(Not included Carbon film ±5% ,1/4W Type)			
VR102-104	211 6077 954	Adjust 22K ohm	V06PB223(M)
VR300,301	211 6077 938	Adjust 100K ohm	V06PB104(M)
VR601	211 0764 001	Variable 20K ohm	V0920FA203
CAPACITORS GROUP			
C106	255 4232 995	Film 0.0033μ/100V	CQ93P2A332JT

● Parts indicated with the mark "◆" is substitute in Japan.

Ref.No	Part .No	Part Name	Remarks
C107	256 1034 908	Metallized 0.027μ/50V	CF93A1H273JT
C108	255 4232 982	Film 0.0022μ/100V	CQ93P2A222JT
C109-112	256 1034 979	Metallized 0.1μ/50V	CF93A1H104JT
C113	254 4337 910	Electrolytic 6.8μ/50V	CE04W1H6R8MT
C114	256 1035 910	Metallized 0.22μ/50V	CF93A1H224JT
C116	255 4235 934	Film 0.01μ/100V	CQ93P2A103JT
C117	253 9039 906	Ceramic 0.1μ/25V	CK45=1E104ZT
C118,119	253 1180 921	Ceramic 0.001μ/50V	CK45B1H102KT
C120	253 9039 906	Ceramic 0.1μ/25V	CK45=1E104ZT
C121	253 1181 904	Ceramic 0.01μ/50V	CK45F1H103ZT
C122,123	254 4260 919	Electrolytic 0.22μ/50V	CE04W1HR22MT
C124	255 4235 934	Film 0.01μ/100V	CQ93P2A103JT
C125	256 1034 911	Metallized 0.033μ/50V	CF93A1H333JT
C126	255 4235 934	Film 0.01μ/100V	CQ93P2A103JT
C127	255 4232 995	Film 0.0033μ/100V	CQ93P2A332JT
C128	255 4237 903	Film 0.0027μ/100V	CQ93P2A272JT
C129	253 9039 906	Ceramic 0.1μ/25V	CK45=1E104ZT
C130	253 1179 990	Ceramic 560p/50V	CK45B1H561KT
C131	255 4235 934	Film 0.01μ/100V	CQ93P2A103JT
C132	253 4538 910	Ceramic 75p/50V	CC45SL1H750JT
C133	253 4536 909	Ceramic 10p/50V	CC45SL1H100DT
C134	256 1034 979	Metallized 0.1μ/50V	CF93A1H104JT
C135	254 3055 918	Electrolytic 10μ/35V Bipolar	CE04D1V100MBPT
C136	253 4443 908	Ceramic 200p/50V	CC45SL1H201JT
C137,138	254 4260 964	Electrolytic 3.3μ/50V	CE04W1H3R3MT
C140	255 4235 934	Film 0.01μ/100V	CQ93P2A103JT
C141	253 4538 949	Ceramic 100p/50V	CC45SL1H101JT
C142	253 9039 906	Ceramic 0.1μ/25V	CK45=1E104ZT
C160-163	253 1180 921	Ceramic 0.001μ/50V	CK45B1H102KT
C164	253 4536 941	Ceramic 15p/50V	CC45SL1H150JT
C166	253 4536 941	Ceramic 15p/50V	CC45SL1H150JT
C168	253 4538 910	Ceramic 75p/50V	CC45SL1H750JT
C170,171	254 4254 938	Electrolytic 47μ/16V	CE04W1C470MT
C173	254 4254 938	Electrolytic 47μ/16V	CE04W1C470MT
C174	253 9039 906	Ceramic 0.1μ/25V	CK45=1E104ZT
C201	253 9039 906	Ceramic 0.1μ/25V	CK45=1E104ZT
C202,203	253 1181 904	Ceramic 0.01μ/50V	CK45F1H103ZT
C210	256 1034 937	Metallized 0.047μ/50V	CF93A1H473JT
C211	253 1180 947	Ceramic 0.0015μ/50V	CK45B1H152KT
C212,213	253 9039 906	Ceramic 0.1μ/25V	CK45=1E104ZT
C212,213	253 1179 987	Ceramic 470p/50V	CK45B1H471KT
C214	254 4387 708	Electrolytic 470μ/50V	CE04W1H471M
C220	254 4260 922	Electrolytic 0.33μ/50V	CE04W1HR33MT
C222	253 4537 937	Ceramic 36p/50V	CC45SL1H360JT
C223	253 4535 939	Ceramic 3p/50V	CC45SL1H030CT
C224	253 4535 955	Ceramic 5p/50V	CC45SL1H050CT
C301	253 1179 961	Ceramic 330p/50V	CK45B1H331KT
C305,306	255 4232 911	Film 180p/100V	CQ93P2A181JT
C307,308	255 4232 908	Film 820p/100V	CQ93P2A821JT
C311,312	255 4232 937	Film 0.001μ/100V	CQ93P2A102JT
C313,314	255 4232 979	Film 200p/100V	CQ93P2A201JT
C317	253 9039 906	Ceramic 0.1μ/25V	CK45=1E104ZT
C318	254 4254 925	Electrolytic 33μ/16V	CE04W1C330MT
C321,322	253 9039 906	Ceramic 0.1μ/25V	CK45=1E104ZT
C327	254 4250 929	Electrolytic 100μ/6.3V	CE04W0J101MT
C328-331	254 4356 713	Electrolytic 100μ/50V	CE04W1H101MC
C501,502	254 4356 768	Electrolytic 2200μ/50V	CE04W1H222MC

Ref.No	Part .No	Part Name	Remarks
C507	254 4313 031	Electrolytic 47μ/50V	CE04W1H470M
C508	254 4313 701	Electrolytic 100μ/50V	CE04W1H101MC
C509,510	254 4261 905	Electrolytic 33μ/50V	CE04W1H330MT
C512	253 1122 905	Ceramic 0.0068μ/50V	CK45B1H682KT
C513	254 4313 714	Electrolytic 330μ/50V	CE04W1H331MC
C514	253 9039 906	Ceramic 0.1μ/25V	CK45=1E104ZT
C600-603	253 1181 904	Ceramic 0.01μ/50V	CK45F1H103ZT
C701	253 9039 906	Ceramic 0.1μ/25V	CK45=1E104ZT
C701	254 4260 977	Electrolytic 4.7μ/50V	CE04W1H4R7MT
C703	253 4443 908	Ceramic 200p/50V	CC45SL1H201JT
C704	254 4254 954	Electrolytic 220μ/16V	CE04W1C221MT
C705,706	253 4537 982	Ceramic 56p/50V	CC45SL1H560JT
C707,708	254 4254 941	Electrolytic 100μ/16V	CE04W1C101MT
C708,709	253 4537 924	Ceramic 33p/50V	CC45SL1H330JT
C712,713	254 4356 713	Electrolytic 100μ/50V	CE04W1H101MC
C714,715	254 4254 909	Electrolytic 10μ/16V	CE04W1C100MT
C716-719	254 4356 742	Electrolytic 470μ/50V	CE04W1H471MC
C720-723	254 4356 713	Electrolytic 100μ/50V	CE04W1H101MC
C731	253 4538 949	Ceramic 100p/50V	CC45SL1H101JT
C800-803	253 1180 921	Ceramic 0.001μ/50V	CK45B1H102KT
C804	253 4538 949	Ceramic 100p/50V	CC45SL1H101JT
C805	253 1181 904	Ceramic 0.01μ/50V	CK45F1H103ZT
C806	253 4536 983	Ceramic 22p/50V	CC45SL1H220JT
C807	253 9039 906	Ceramic 0.1μ/25V	CK45=1E104ZT
C807,808	253 9039 906	Ceramic 0.1μ/25V	CK45=1E104ZT

OTHER PARTS

X200	399 0165 007	Crystal Oscillator	16.3344 MHz
X201	399 0111 006	Ceramic Oscillator	CS14.23MGW040
RM601	499 0150 008	REMOTE SENSOR	SB1610-52
PT300	231 8063 009	PULSE TRANS	
JK?	204 8322 007	HEAD PHONE JACK	
JK701	204 8256 005	1P PIN JACK	(DIGITAL OUT)
JK?	204 8261 016	4P PIN JACK	(FIX-VARI. OUT)
U701	269 0096 008	OPTICAL CONN.	(OPTICAL OUT)
LCD601	393 4095 007	FL TUBE	FIP05NM6
CB101	205 0321 054	5P CONNECTOR BASE(RED)	
CB102	205 0343 058	5P CONNECTOR BASE(KR-PH)	
CB103	205 0683 006	FFC CONNECTOR BASE(12P)	
CB203	205 0549 001	31P FFC CONNECTOR BASE	
CB500	205 0406 092	9P CONNECTOR BASE(KR-PH)	
CB601	205 0549 001	31P FFC CONNECTOR BASE	
CB602	205 0343 045	4P CONNECTOR BASE(KR-PH)	
TP101,102	205 0190 065	6P MH CONNECTOR BASE	

3U-1879 POWER SUPPLY UNIT (DCD-1290)
[U.S.A.,Canada and Australia Models]

Ref.No	Part .No	Part Name	Remarks
C900	253 8014 702	Ceramic 0.01μ/400VAC	CK45F2GAC103MC
SW	212 4697 009	POWER SWITCH	
CC500	204 0223 007	6P SAN-PH CORD	
	205 0581 001	2P VH CONNECTOR BASE	
⚠	233 5795 004	POWER TRANSFORMER	U.S.A., Canada
⚠	233 5796 003	POWER TRANSFORMER	Australia

PACKING & ACCESSORIES (DCD-1290)
[Europe and U.K. Models]

Ref.No	Part .No	Part Name	Remarks	Q'ty
◆	504 0125 005	: STYRENE PAPER	for AC CORD	1
	504 0092 060	STYRENE PAPER	for AC CORD	
◆	505 0131 050	CABINET COVER		1
	505 0102 092	STYRENE PAPER		
◆	505 0178 000	: POLY COVER		1
	505 0038 030	POLY COVER		
◆	503 0861 007	: CUSHION		2
	503 0794 006	CUSHION		
◆	501 1408 078	: CARTON CASE		1
	511 2336 007	: INST.MANUAL	Europe	1
	511 2348 105	INST MANUAL	U.K.	1
	203 2310 009	2P PIN CORD		1
	499 9005 002	REMOTE CONTROLLER(RC235)	Without Battery	1
	394 0021 007	: BATTERY (SUM-3)		1

● Parts indicated with the mark "◆" is substitute in Japan.

(3U-2023) POWER SUPPLY UNIT (DCD-1290)
[Europe and U.K. Models]

Ref.No	Part .No	Part Name	Remarks
C900	253 8014 702	Ceramic 0.01μ/400VAC	CK45F2GAC103MC
SW	212 4697 009	POWER SWITCH	
	204 0286 002	6P KR-DA CONNECTOR CORD	
CB500	205 0624 007	: 2P AC CONNECTOR BASE	
⚠	233 5794 018	POWER TRANSFORMER	

PACKING & ACCESSORIES (DCD-2060G)
[Multi-Voltage(Asia)Model]

Ref.No	Part .No	Part Name	Remarks	Q'ty
	504 0092 060	STYRENE PAPER	for AC CORD	1
	505 0102 092	STYRENE PAPER		1
	505 0038 030	POLY COVER		1
	503 0794 006	CUSHION		2
	501 1620 021	CARTON CASE		1
	513 9111 001	COLOR LABEL (GOLD)		1
	511 2348 105	INST. MANUAL		1
	203 6305 007	2P PIN CORD		1
	499 9004 003	REMOTE CONTROLLER (RC234)		1

3U-1879B POWER SUPPLY UNIT (DCD-2060G/2060)
[Multi-Voltage(Asia)Model]

Ref.No	Part .No	Part Name	Remarks
C900	253 8014 702	Ceramic 0.01μ/400VAC	CK45F2GAC103MC
SW	212 4697 009	POWER SWITCH	
Cc500	204 2294 021	2P SAN-PH CONNECTOR CORD	
	205 0581 001	2P VH CONNECTOR BASE	
⚠	233 5772 001	POWER TRANSFORMER	
⚠	212 4698 008	VOLTAGE SELECTOR	

PACKING & ACCESSORIES (DCD-1290)
[U.S.A.,Canada and Australia Models]

Ref.No	Part .No	Part Name	Remarks	Q'ty
	504 0092 060	STYRENE PAPER	for AC CORD	1
	505 0102 092	STYRENE PAPER		1
	505 0038 030	POLY COVER		1
	503 0794 006	CUSHION		2
	501 1408 081	CARTON CASE		1
	511 2348 105	INST. MANUAL	U.S.A.	1
			Australia	
			Canada	
	511 2336 007	: INST. MANUAL		1
	203 6305 007	2P PIN CORD		1
	499 9004 003	REMOTE CONTROLLER(RC234)		1
	515 0418 408	DAI WARRANTY HOME 4	U.S.A.	1
	515 0569 001	DCI WARRANTY HOME	Canada	1

PACKING & ACCESSORIES (DCD-2060)
[Multi-Voltage(Asia)Model]

Ref.No	Part .No	Part Name	Remarks	Q'ty
	504 0092 060	STYRENE PAPER	for AC CORD	1
	505 0102 092	STYRENE PAPER		1
	505 0038 030	POLY COVER		1
	503 0794 006	CUSHION		2
	501 1408 094	CARTON CASE		1
	511 2348 105	INST. MANUAL		1
	203 6305 007	2P PIN CORD		1
	499 9004 003	REMOTE CONTROLLER (RC234)		1

WARNING:

Parts marked with " ⚠ " and/shading have special characteristics important to safety.

EXPLODED VIEW OF FG-50 MECHANISM UNIT

PARTS LIST OF FG-50 MECHANISM UNIT

Ref. No.	Part No.	Part Name	Remarks
1	GEN 1396	Clamper Press Sub Ass'y	
3	412 3133 006	Clamper Frame	
5	431 0300 302	Loader Frame	
6	463 0669 008	Lock Lever Spring	
7	412 3215 202	Lock Lever	
8	424 0162 005	Gear	
9	424 0160 104	Lift Cam	
10	477 0262 006	Special Screw	
11	212 1059 006	Open/Close SW.	
12	423 0056 011	Belt	
13	424 0161 103	Pulley Gear	
14	411 1019 300	Mecha. Chassis	
15	GEN 1492	L. Motor Sub Ass'y	
16	222 2275 006	Motor SW. P.W.B.	
17	203 8302 008	5-3, 2P PH-SAN CORD-R	
18	499 0191 009	Laser P.U	KSS-240A
19	443 1094 005	P.U. Shaft	
20	471 3801 039	2x3 CBS-Z	
21	GEN 1636	Spindle Motor Ass'y	
22	424 0164 003	Helical Gear	
23	GEN 1397	Slide Motor Sub Ass'y	
24	462 0078 104	Damper	
25	203 8301 009	5-3, 2P PH-SAN CORD-W	
26	443 1093 006	FFC Clamper	
27	212 6013 005	Inner SW. (PU)	
28	009 0051 001	12P FFC	
29	462 0078 117	Damper	
30	463 0583 100	Spring (F)	
31	GEN 1408	Mecha. Frame Sub Ass'y	
32	461 0661 000	Spring F. (R)	
33	435 0117 403	Slide Rack	
34	462 0113 014	Rubber Washer	
35	473 7508 017	3 x 10 CBTS (P)-B	
36	412 3478 007	Stopper	

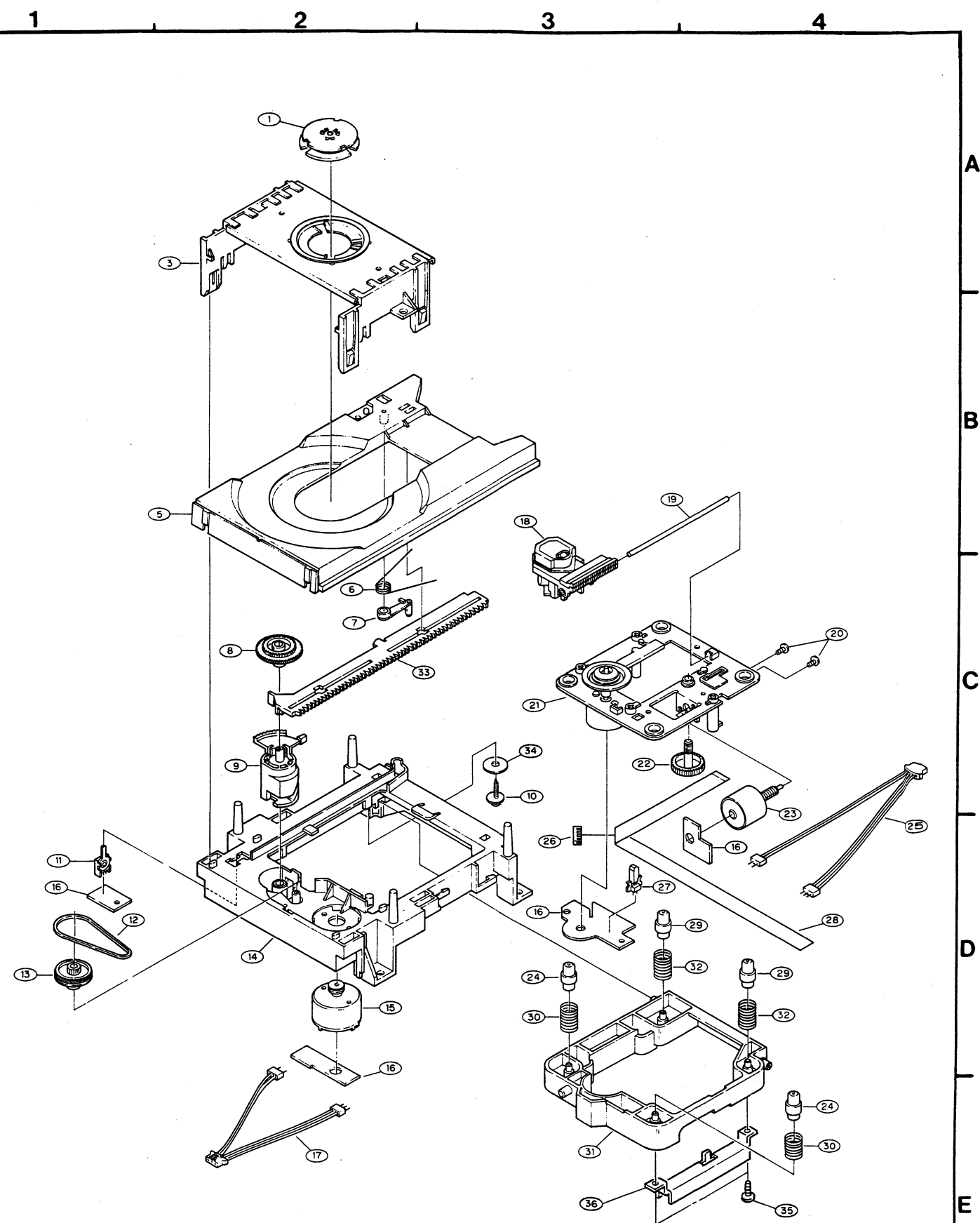

PARTS LIST OF EXPLODED VIEW (DCD-1290)
[U.S.A.,Canada and Australia Models]

Ref.No	Part .No	Part Name	Remarks
1	411 0884 617	CHASSIS	
2	105 0879 141	REAR PANEL (EU)	
3	103 1192 106	PIN JACK HOLDER	
4	105 0814 504	BOTTOM COVER	
6	3U-2455	MAIN UNIT	
7	3U-1879	POWER SUPPLY UNIT	
8	233 5795 001	POWER TRANSFORMER	U.S.A., Canada
8	233 5795 100	POWER TRANSFORMER	Australia
9	206 2100 001	AC CORD WITH CONNECTOR	U.S.A., Canada
9	206 2087 001	AC CORD WITH CONNECTOR	Australia
10	445 0056 008	CORD BUSH	
12	113 1067 267	POWER SWITCH LEVER ASS'Y	
13	FG 50	CD MECHA. UNIT	
15	212 4697 009	POWER SWITCH	
16	435 0113 009	LATCH(Y3Y18)	
17	112 0572 132	VOLUME KNOB	
18	GEN 2036	FRONT PANEL ASS'Y	
19	144 1946 285	FRONT PANEL	
20	146 1103 451	SUB PANEL ASS'Y	
21	113 1223 027	SERIES KNOB(12)	
22	113 1223 030	SERIES KNOB(11)	
23	113 1545 000	FUNCTION KNOB(A)	
24	113 1298 311	OPEN/CLOSE KNOB	
25	102 0408 319	TOP COVER	
26	113 1299 019	MANUAL SEARCH KNOB	
28	146 0772 003	TOP COVER WASHER	
29	009 0011 009	31P FFC CABLE	
30	393 4095 007	FL TUBE (FIP 10SM6)	
31	204 8322 007	HEAD PHONE JACK	
32	211 0764 001	V0290FA203	H/P VOLUME
33	269 0096 008	HFBR 1550	OPTICAL OUT
35	204 8261 003	4P PIN JACK	ANALOG OUT
36	204 8256 005	1P PIN JACK	COAXIAL. OUT
37	144 1955 014	TRAP DOOR	
38	401 0135 301	HINGE(LEFT)	
39	401 0174 207	HINGE(RIGHT)	
48	129 0155 117	RUBBER SHEET	
49	412 2812 402	MECHA.FIX BRACKET	
50	412 2882 005	TOP PLATE	
51	122 0181 009	SOUND RUBBER	
57	144 2203 011	LODAER PANEL ASS'Y	
58	104 0194 001	FOOT ASS'Y	
59	421 9007 007	MINI DAMPER	
70	499 0150 008	REMOTE SENSOR (SBX1610-52)	
71	212 5604 910	TACT SWITCH	
72	205 0549 001	31P FFC CONNECTOR BASE	
75	412 2874 107	TRANS.SUPPORT PLATE	
101	473 7002 021	3X8 CBTS(S)-B SCREW	
102	473 7508 017	3X10 CBTS(P)-B SCREW	
103	473 7500 015	3X8 CBTS(P)-Z SCREW	
104	471 9020 018	SPECIAL SCREW	
105	473 4454 025	4X8 CTTS(2) BKNI SCREW	
106	473 7002 021	3X8 CBTS(S)-B SCREW	

PARTS LIST OF EXPLODED VIEW (DCD-1290)
[Europe and U.K. Models]

Ref.No	Part .No	Part Name	Remarks
1	411 0947 208	: CHASSIS	
2	105 0890 214	: REAR PANEL	
3	103 1192 106	PIN JACK HOLDER	
4	105 0891 103	: BOTTOM COVER	
4	105 0814 504	BOTTOM COVER	
6	3U-2431	MAIN UNIT	
7	3U-2023	POWER SUPPLY UNIT	
8	233 5794 018	POWER TRANSFORMER	
9	206 2091 000	AC CORD WITH CONNECTOR	Europe
9	206 2092 009	AC CORD WITH CONNECTOR	U.K.
10	445 0056 008	CORD BUSH	
12	113 1067 267	POWER SWITCH LEVER ASS'Y	
12	113 1067 254	POWER SWITCH LEVER ASS'Y	(Gold)
13	FG 50	CD MECHA. UNIT	
15	212 4697 009	POWER SWITCH	
16	435 0113 009	LATCH(Y3Y18)	
17	112 0572 132	VOLUME KNOB	
17	112 0572 145	VOLUME KNOB	(Gold)
18	GEN 1993	FRONT PANEL ASS'Y	
18	GEN 1993 -1	FRONT PANEL ASS'Y	(Gold)
19	144 1946 256	FRONT PANEL	
19	144 1946 269	FRONT PANEL	(Gold)
20	146 1128 326	: SUB PANEL ASS'Y	
20	146 1128 339	: SUB PANEL ASS'Y	(Gold)
21	113 1223 027	SERIES KNOB(12)	
21	113 1223 043	SERIES KNOB(12)	(Gold)
22	113 1223 030	SERIES KNOB(11)	
22	113 1223 056	SERIES KNOB(11)	(Gold)
23	113 1545 019	FUNCTION KNOB(A)	
23	113 1545 035	FUNCTION KNOB(A)	(Gold)
24	113 1298 311	OPEN/CLOSE KNOB	
24	113 1298 324	OPEN/CLOSE KNOB	(Gold)
25	102 0414 109	: TOP COVER	
25	102 0414 112	: TOP COVER	(Gold)
26	113 1299 019	MANUAL SEARCH KNOB	
26	113 1299 022	MANUAL SEARCH KNOB	(Gold)
28	146 0772 003	TOP COVER WASHER	
28	146 0772 016	TOP COVER WASHER	(Gold)
29	009 0011 009	31P FFC CABLE	
30	393 4095 007	FL TUBE (FIP 10SM6)	
31	204 8322 007	HEAD PHONE JACK	
32	211 0764 001	V0290FA203	H/P VOLUME
33	269 0096 008	HFBR 1550	OPTICAL OUT
35	204 8261 003	4P PIN JACK	ANALOG OUT
36	204 8256 005	1P PIN JACK	COAXIAL. OUT
37	144 1955 014	TRAP DOOR	
37	144 1955 043	TRAP DOOR	(Gold)
38	401 0135 314	HINGE(LEFT)	
38	401 0135 330	HINGE(LEFT)	(Gold)
39	401 0174 210	HINGE(RIGHT)	
39	401 0174 236	HINGE(RIGHT)	(Gold)
40	135 0059 108	U.K. PLATE	U.K. Only
48	129 0155 104	RUBBER SHEET	
49	412 2982 206	: MECHA.FIX BRACKET	

PARTS LIST OF EXPLODED VIEW (DCD-2060)
[Multi-Voltage(Asia)Model]

Ref.No	Part .No	Part Name	Remarks
50	412 2983 108	: TOP PLATE	
50	412 2882 005	TOP PLATE	
51	122 0181 009	SOUND RUBBER	
57	144 2203 008	LOADER PANEL ASS'Y	
57	144 2203 037	LOADER PANEL ASS'Y	(Gold)
58	104 0228 207	: FOOT ASS'Y	
58	104 0194 001	FOOT ASS'Y	
59	421 9007 007	MINI DAMPER	
70	499 0150 008	REMOTE SENSOR (SBX1610-52)	
71	212 5604 910	TACT SWITCH	
72	205 0549 001	31P FFC CONNECTOR BASE	
75	412 2874 107	TRANS.SUPPORT PLATE	
101	473 7002 021	3X8 CBTS(S)-B SCREW	
102	473 7508 017	3X10 CBTS(P)-B SCREW	
103	473 7500 015	3X8 CBTS(P)-Z SCREW	
104	471 9020 018	SPECIAL SCREW	
104	471 9020 005	SPECIAL SCREW	(Gold)
105	473 4454 025	4X8 CTTS(2)BKNI SCREW	
105	473 4801 005	4X8 CTTS SCREW	(Gold)
106	473 7002 021	3X8 CBTS(S)-B SCREW	
106	473 3806 014	3X8 CBTS(S)-B SCREW	(Gold)
1	411 0884 617	CHASSIS	
2	105 0879 154	REAR PANEL	
3	103 1192 106	PIN JACK HOLDER	
4	105 0814 504	BOTTOM COVER	
6	3U-2455 A	MAIN UNIT	
7	3U-1879 B	POWER SUPPLY UNIT	
8	233 5772 108	POWER TRANSFORMER	
9	206 2083 018	AC CORD WITH PLUG	
10	445 0084 009	CORD BUSH	
12	113 1067 267	POWER SWITCH LEVER ASS'Y	
13	FG 50	CD MECHA. UNIT	
15	212 4697 009	POWER SWITCH	
16	435 0113 009	LATCH(Y3Y18)	
17	112 0572 132	VOLUME KNOB	
18	GEN 1993 -5	FRONT PANEL ASS'Y	
19	144 2235 018	FRONT PANEL	
20	146 1103 448	SUB PANEL ASS'Y	
21	113 1223 027	SERIES KNOB(12)	
22	113 1223 030	SERIES KNOB(11)	
23	113 1545 006	FUNCTION KNOB(A)	
24	113 1298 214	OPEN/CLOSE KNOB	
25	102 0408 319	TOP COVER	
26	113 1299 019	MANUAL SEARCH KNOB	
28	146 0772 003	TOP COVER WASHER	
29	009 0011 009	31P FFC CABLE	
30	393 4095 007	FL TUBE (FIP 10SM6)	
31	204 8322 007	HEAD PHONE JACK	
32	211 0764 001	V0290FA203	H/P VOLUME
33	269 0096 008	HFBR 1550	OPTICAL OUT
35	204 8261 003	4P PIN JACK	ANALOG OUT
36	204 8256 005	1P PIN JACK	COAXIAL. OUT
37	144 1955 014	TRAP DOOR	
38	401 0135 301	HINGE(LEFT)	
39	401 0174 207	HINGE(RIGHT)	
48	129 0155 117	RUBBER SHEET	
49	412 2812 402	MECHA.FIX BRACKET	
50	412 2882 005	TOP PLATE	
51	122 0181 009	SOUND RUBBER	
57	144 2203 011	LOADER PANEL ASS'Y	
58	104 0194 001	FOOT ASS'Y	
59	421 9007 007	MINI DAMPER	
70	499 0150 008	REMOTE SENSOR (SBX1610-52)	
71	212 5604 910	TACT SWITCH	
72	205 0549 001	31P FFC CONNCTOR BASE	
75	412 2874 107	TRANS.SUPPORT PLATE	
101	473 7002 021	3X8 CBTS(S)-B SCREW	
102	473 7508 017	3X10 CBTS(P)-B SCREW	
103	473 7500 015	3X8 CBTS(P)-Z SCREW	
104	471 9020 018	SPECIAL SCREW	
105	473 4454 025	4X8 CTTS(2) BKNI SCREW	
106	473 7002 021	3X8 CBTS(S)-B SCREW	

EXPLODED VIEW

(DCD-1290/2060)

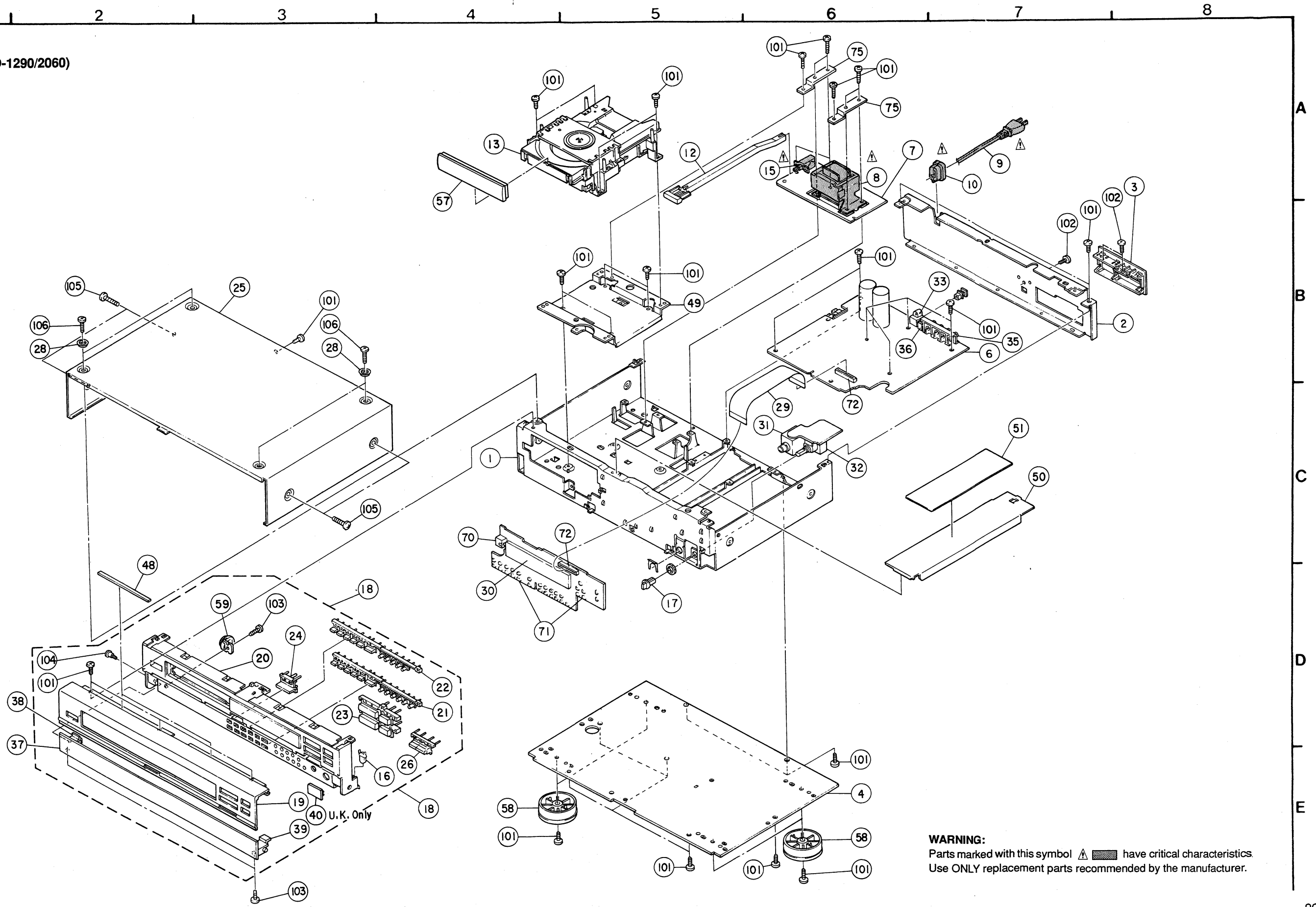

WARNING:
 Parts marked with this symbol ▲ have critical characteristics.
 Use ONLY replacement parts recommended by the manufacturer.

EXPLODED VIEW

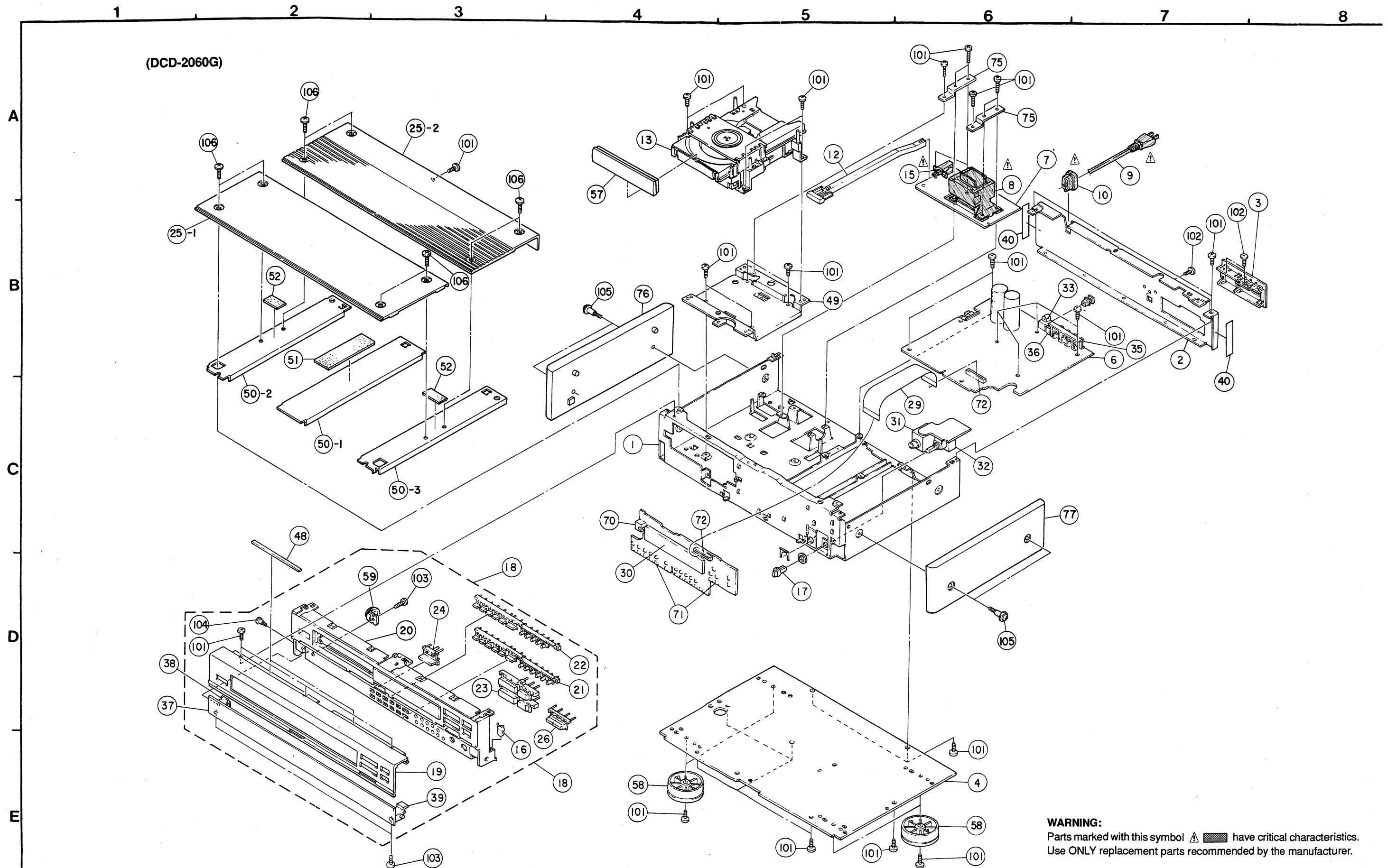

WARNING:
Parts marked with this symbol  have critical characteristics.
Use ONLY replacement parts recommended by the manufacturer.

PARTS LIST OF EXPLODED VIEW (DCD-2060G)
[Multi-Voltage(Asia)Model]

Ref.No	Part .No	Part Name	Remarks
● 1	411 0884 604	CHASSIS	
● 2	105 0879 154	REAR PANEL	
● 3	103 1192 106	PIN JACK HOLDER	
● 4	105 0814 504	BOTTOM COVER	
● 6	3U-2455 A	MAIN UNIT	
⚠ 7	3U-1879 B	POWER SUPPLY UNIT	
⚠ 8	233 5772 108	POWER TRANSFORMER	
⚠ 9	206 2100 001	AC CORD WITH PLUG	
⚠ 10	445 0084 009	CORD BUSH	
12	113 1067 270	POWER SWITCH LEVER ASS'Y	
● 13	FG 50	CD MECHA. UNIT	
⚠ 15	212 4697 009	POWER SWITCH	
16	435 0113 009	LATCH(Y3Y18)	
17	112 0572 158	VOLUME KNOB	
● 18	GEN 1993 -4	FRONT PANEL ASS'Y	
● 19	144 2223 020	FRONT PANEL	
● 20	146 1103 435	SUB PANEL ASS'Y	
21	113 1223 001	SERIES KNOB(12)	
22	113 1223 014	SERIES KNOB(11)	
23	113 1545 022	FUNCTION KNOB(A)	
24	113 1298 308	OPEN/CLOSE KNOB	
● 25-1	144 2220 201	TOP COVER(A)	
● 25-2	144 2242 205	TOP COVER(B)	
26	113 1299 019	MANUAL SEARCH KNOB	
● 29	009 0011 009	31P FFC CABLE	
30	393 4095 007	FL TUBE (FIP 10SM6)	
31	204 8322 007	HEAD PHONE JACK	
32	211 0764 001	V0290FA203	H/P VOLUME
33	269 0096 008	HFBR 1550	OPTICAL OUT
35	204 8261 003	4P PIN JACK	ANALOG OUT
36	204 8256 005	1P PIN JACK	COAXIAL. OUT
37	144 1955 001	TRAP DOOR	
38	401 0135 327	HINGE(LEFT)	
39	401 0174 222	HINGE(RIGHT)	
● 40	125 0071 008	8 × 70 SPACER	
48	129 0155 104	RUBBER SHEET	
● 49	412 2812 402	MECHA.FIX BRACKET	
● 50-1	412 3560 009	TOP PLATE(C)	
● 50-2	412 3558 008	TOP PLATE(L)	
● 50-3	412 3559 007	TOP PLATE(R)	
● 51	461 0710 029	SPACER RUBBER(C)	
● 52	461 0710 016	SPACER RUBBER	
57	144 2203 024	LOADER PANEL ASS'Y	
58	104 0194 001	FOOT ASS'Y	
59	421 9007 007	MINI DAMPER	
70	499 0150 008	REMOTE SENSOR (SBX1610-52)	
71	212 5604 910	TACT SWITCH	
72	205 0549 001	31P FFC CONNECTOR BASE	
● 75	412 2874 107	TRANS.SUPPORT PLATE	
● 76	101 2432 005	SIDE WOOD BOARD(L)	
● 77	101 2433 004	SIDE WOOD BOARD(R)	
101	473 7002 021	3X8 CBTS(S)-B SCREW	
102	473 7508 017	3X10 CBTS(P)-B SCREW	
103	473 7500 015	3X8 CBTS(P)-Z SCREW	
104	473 7514 001	SPECIAL SCREW	
105	473 8027 005	SPECIAL SCREW	
106	473 4810 106	3X10 SP. SCREW	

P.W.BOARD
3U-1879/3U-2033 POWER SUPPLY UNIT

For U.S.A./Canada
3U-1879

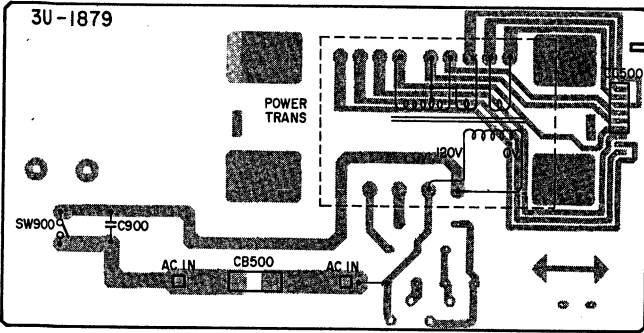

For Europe
3U-2023

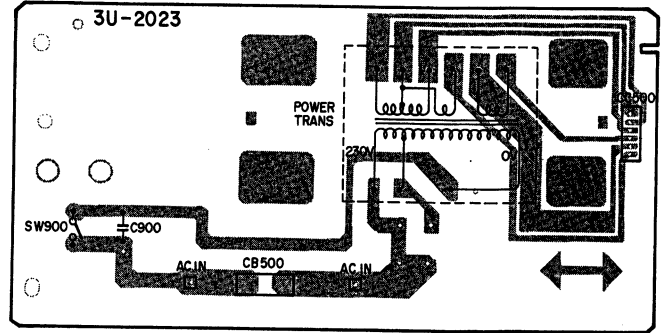

For Australia
3U-1879

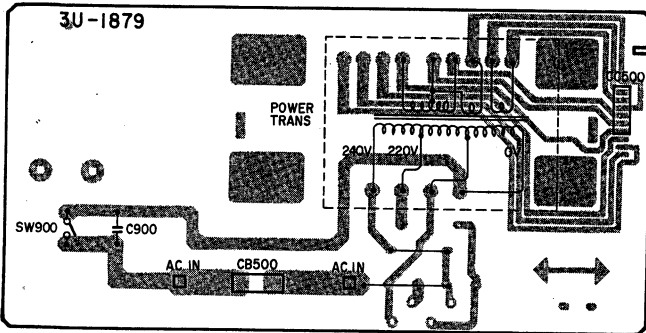

For U.K.
3U-2023

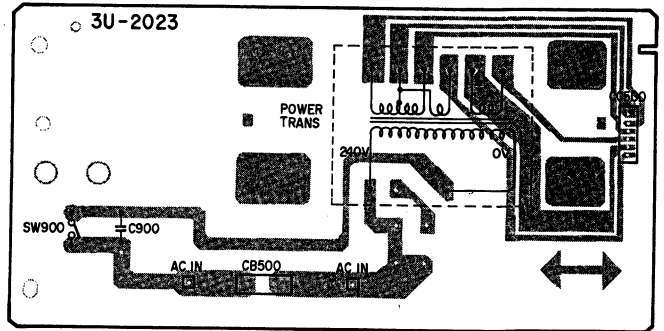

For Multi-Voltage (Asia)
3U-1879

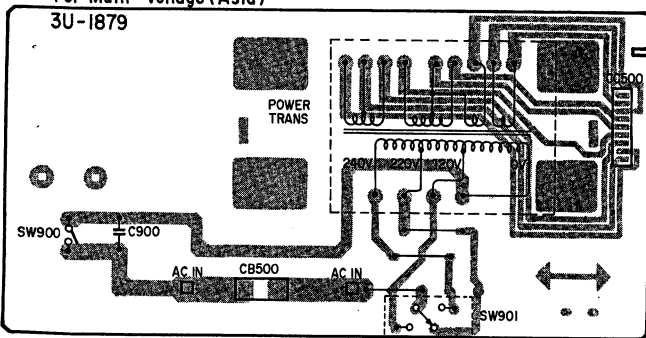

3U-2455 MAIN UNIT

1 2 3 4 5 6 7 8

(U.S.A. Canada Australa, and Multi-Voltage (Asia) Models)

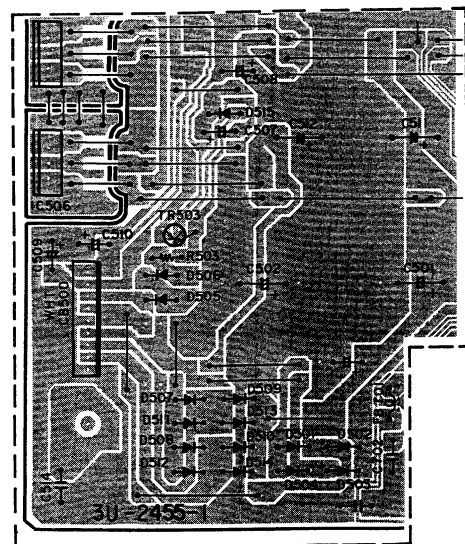

Multi-Voltage (Asia) Models

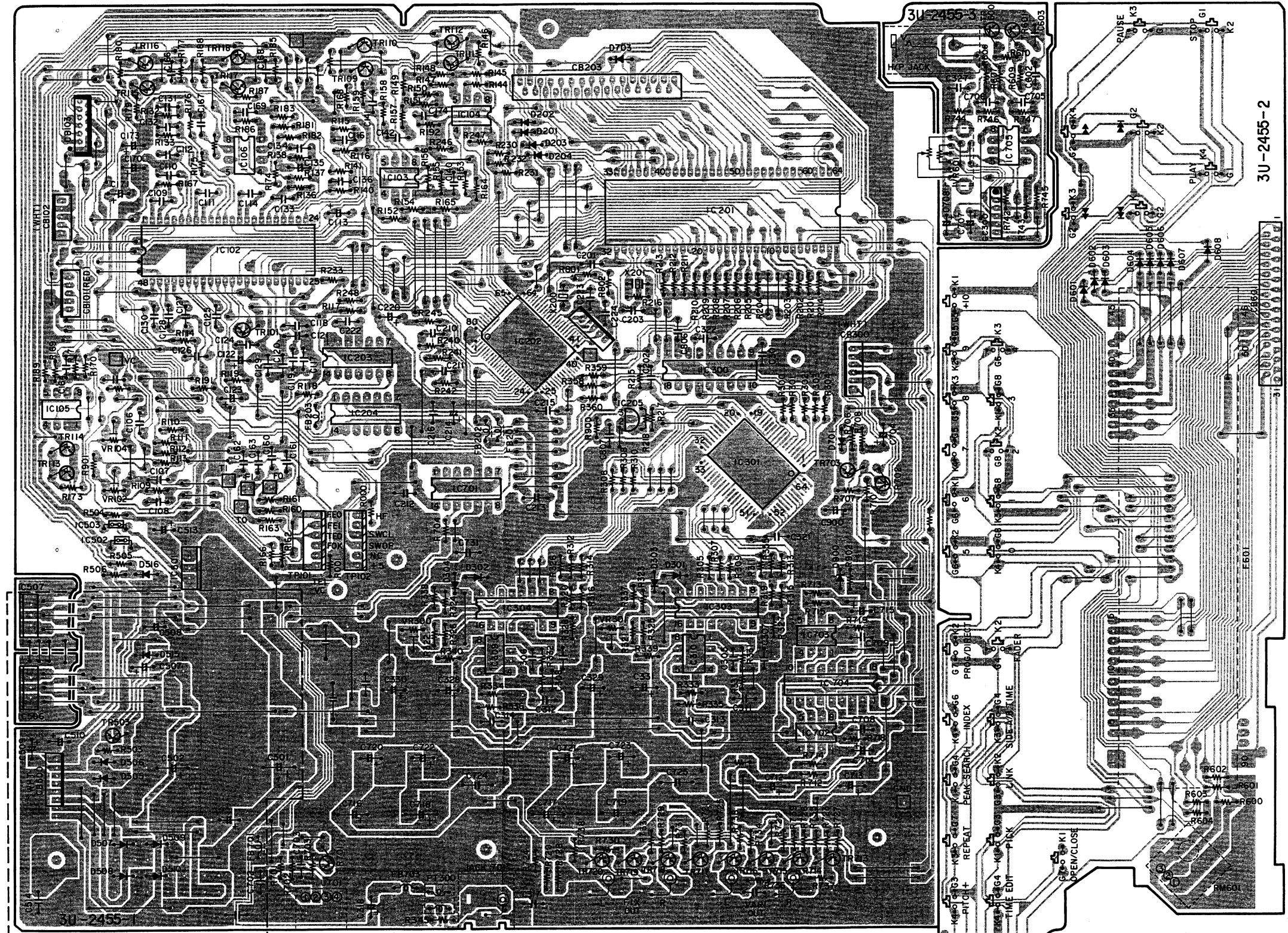

U.S.A., Canada and Australa Models

A
B
C
D
E

3U-2431 MAIN UNIT

1

2

3

4

5

6

7

8

(Europe and U.K. Models)

A

B

C

D

E

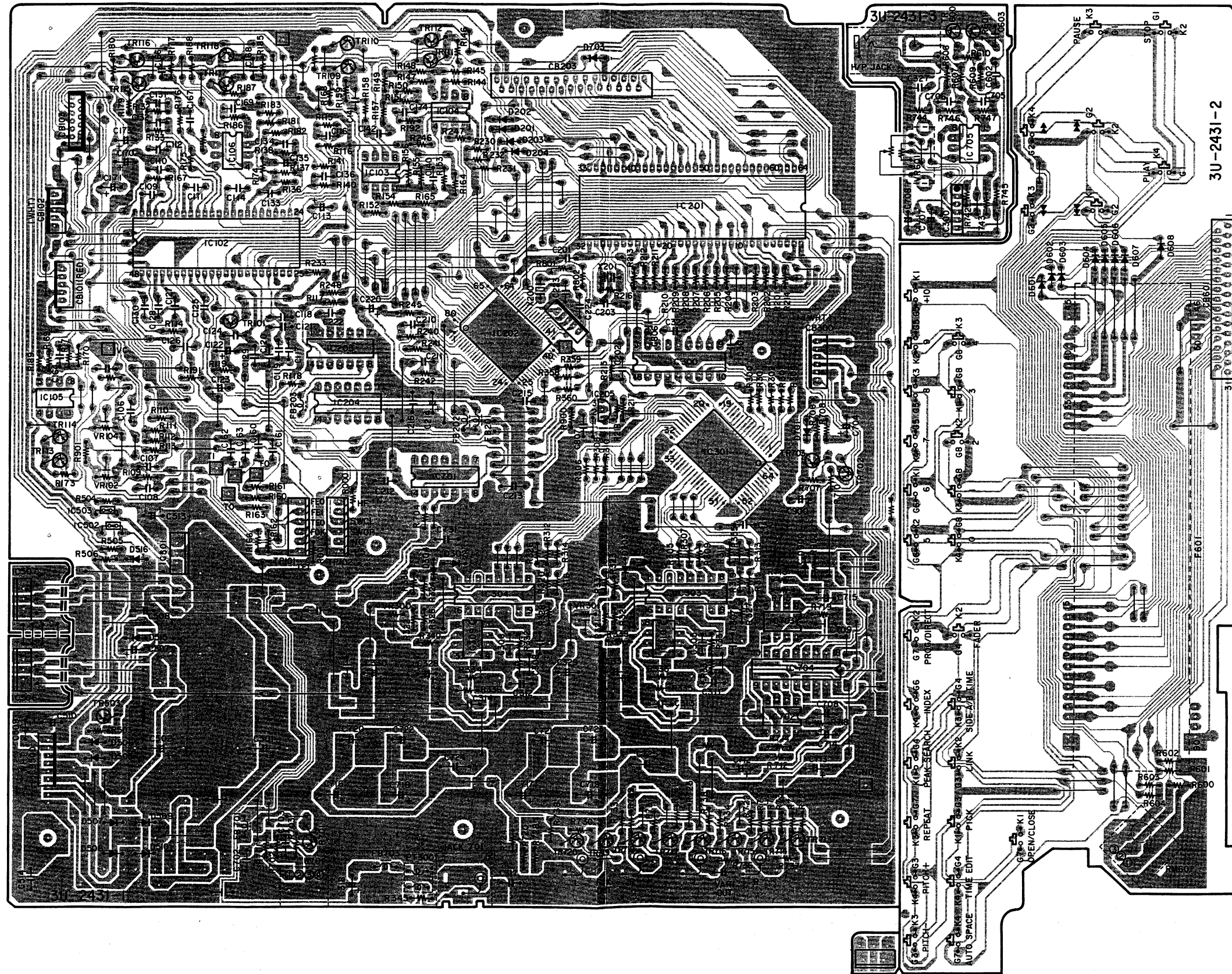

3U-2431-2

WIRING DIAGRAM

1 2 3 4 5 6 7 8

A

B

C

D

E

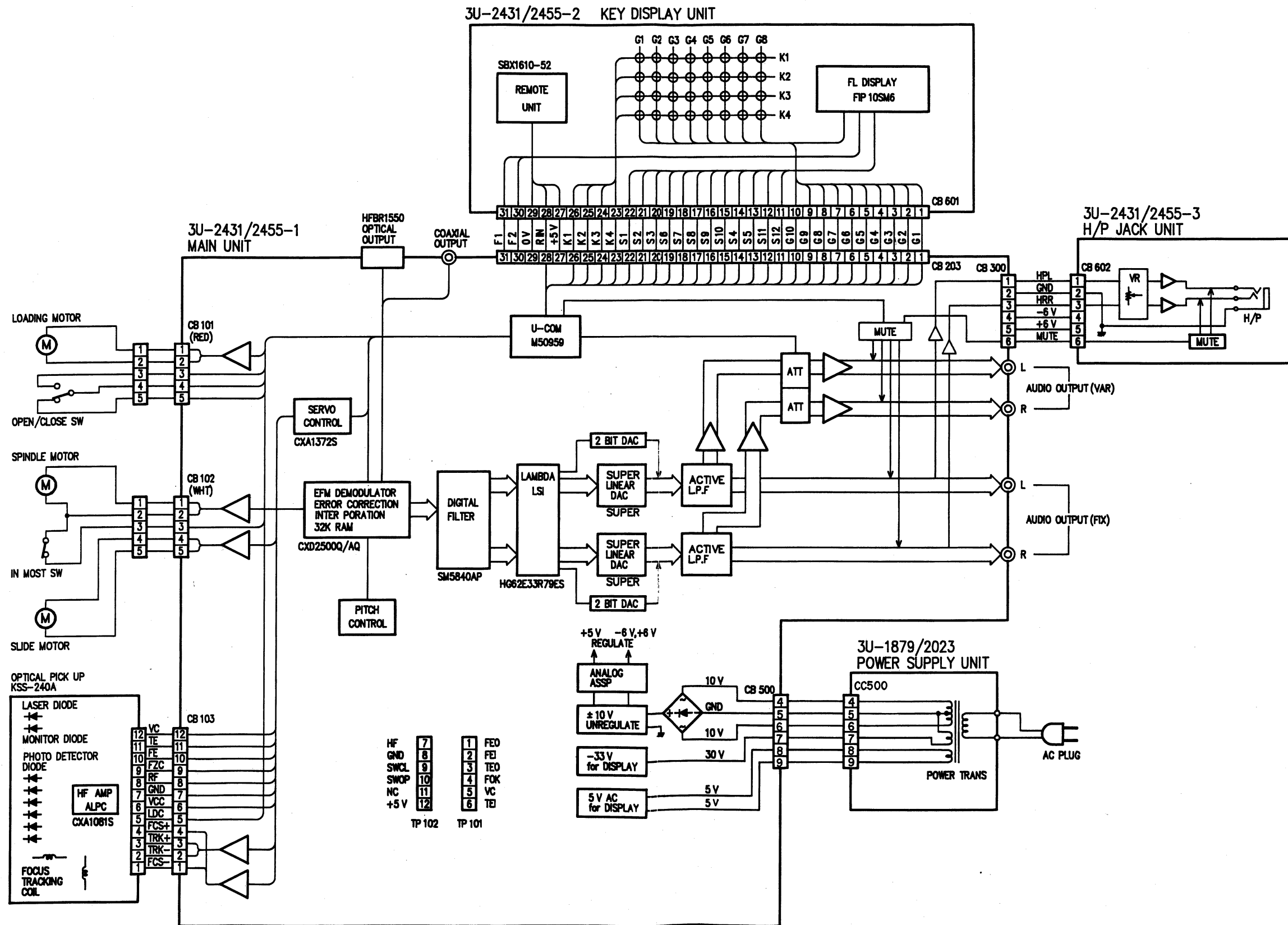

SCHEMATIC DIAGRAM [DCD-2060/2060G] (Multi-Voltage Model)

1 2 3 4 5 6

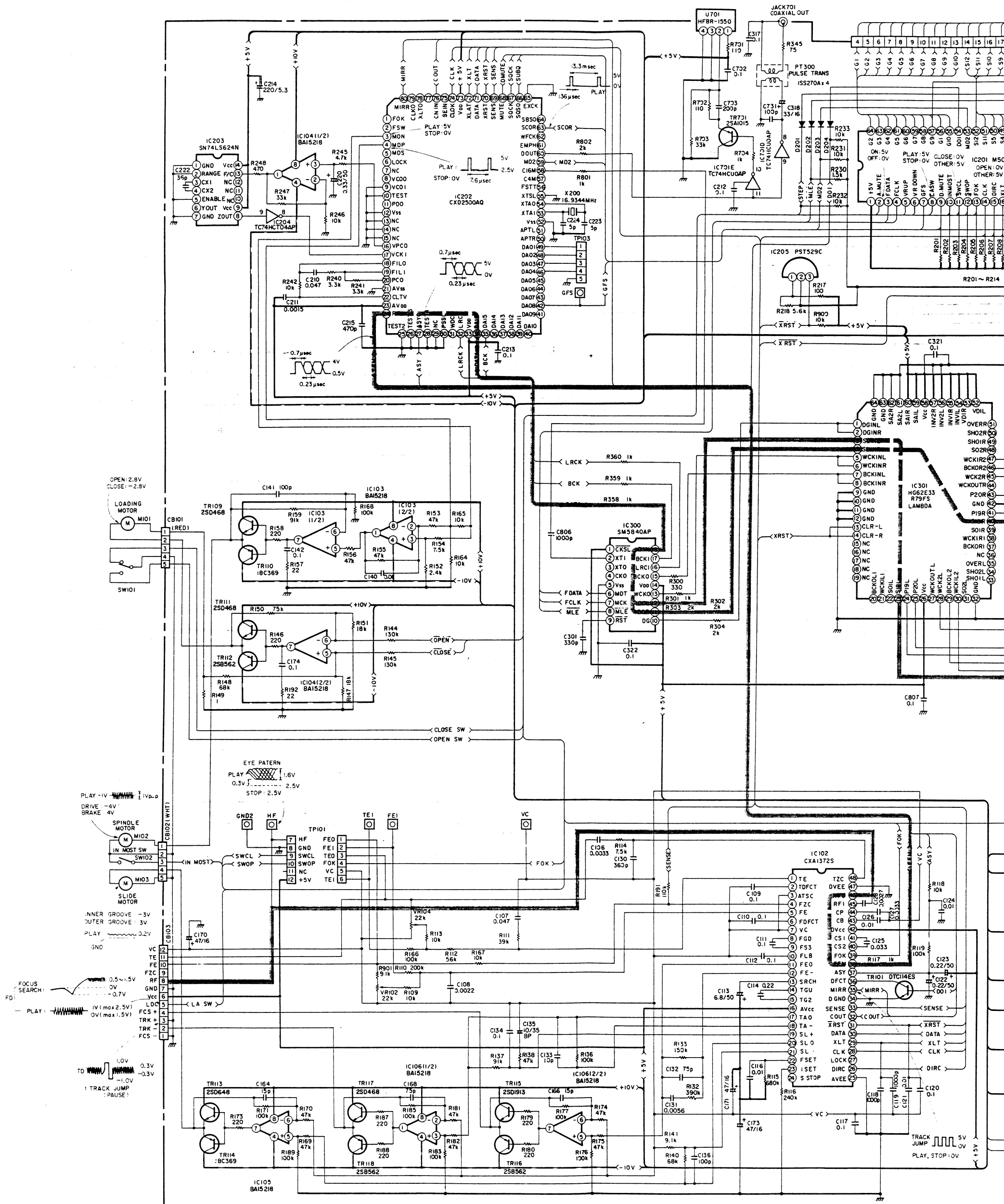

WARNING:
 Parts marked with this symbol  Use ONLY replacement parts specified by the manufacturer.
CAUTION:
 Before returning the unit to the customer, check for leakage current. If the leakage current exceeds 0.5 milliamperes, the unit is defective.
WARNING:
 DO NOT return the unit to the customer until it is repaired.

6 7 8 9 10 11

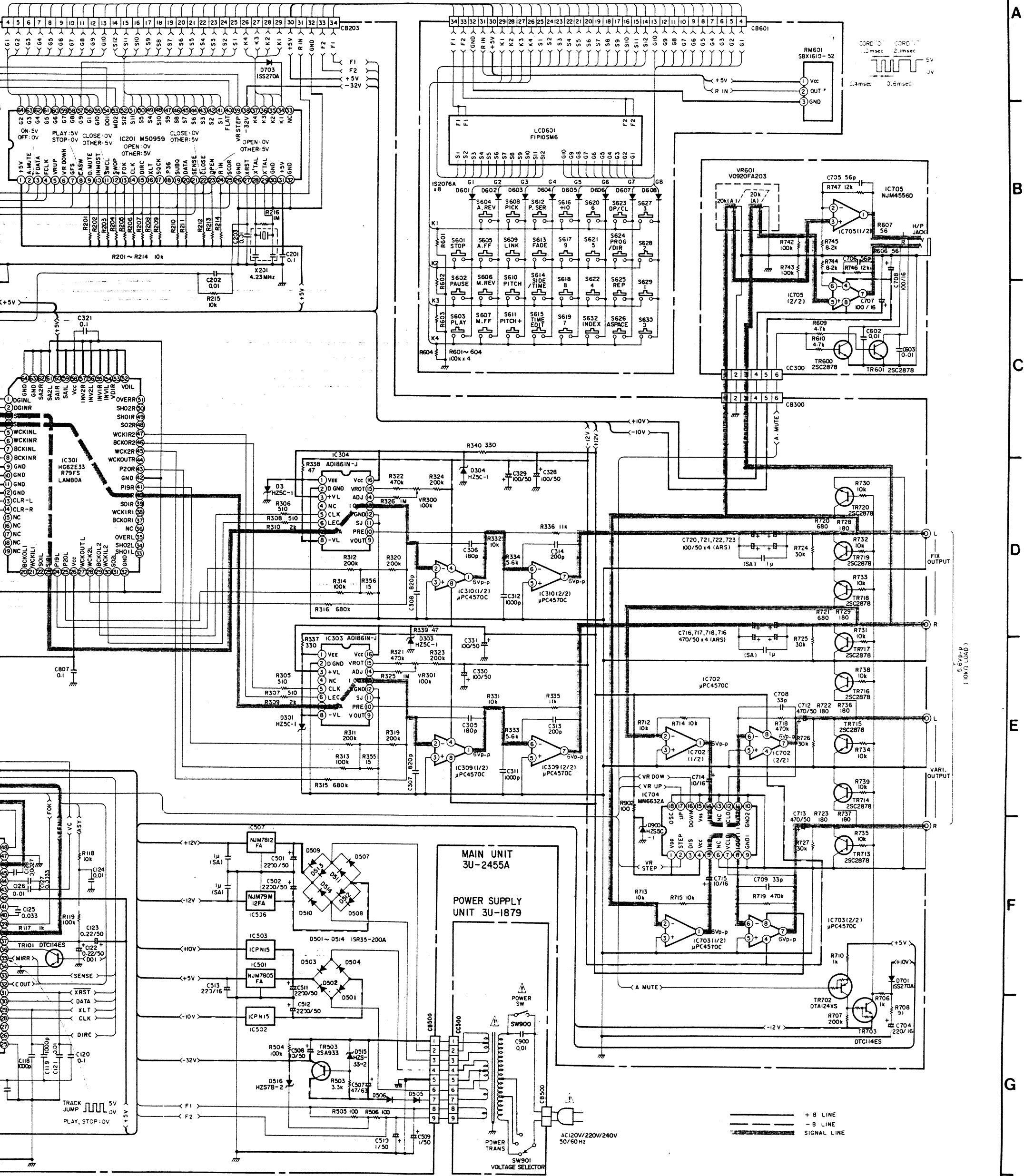

WARNING:
 Components marked with this symbol have critical characteristics.
 Use ONLY replacement parts specified by the manufacturer.

CAUTION:
 Before returning the unit to the customer, make sure you make either (1) a leakage current check or (2) a line to chassis resistance check.
 The leakage current exceeds 0.5 milliamperes, or if the resistance from chassis to either side of the power cord is less than 240 kohms, the unit is defective.

WARNING:
 Do NOT return the unit to the customer until the problem is located and corrected.

NOTES
 ALL RESISTANCE VALUES IN OHM. k=1,000 OHM, M=1,000,000 OHM
 ALL CAPACITANCE VALUES IN MICRO FARAD. P=MICRO-MICRO FARAD
 EACH VOLTAGE AND CURRENT ARE MEASURED AT NO SIGNAL INPUT CONDITION.
 CIRCUIT AND PARTS ARE SUBJECT TO CHANGE WITHOUT PRIOR NOTICE.

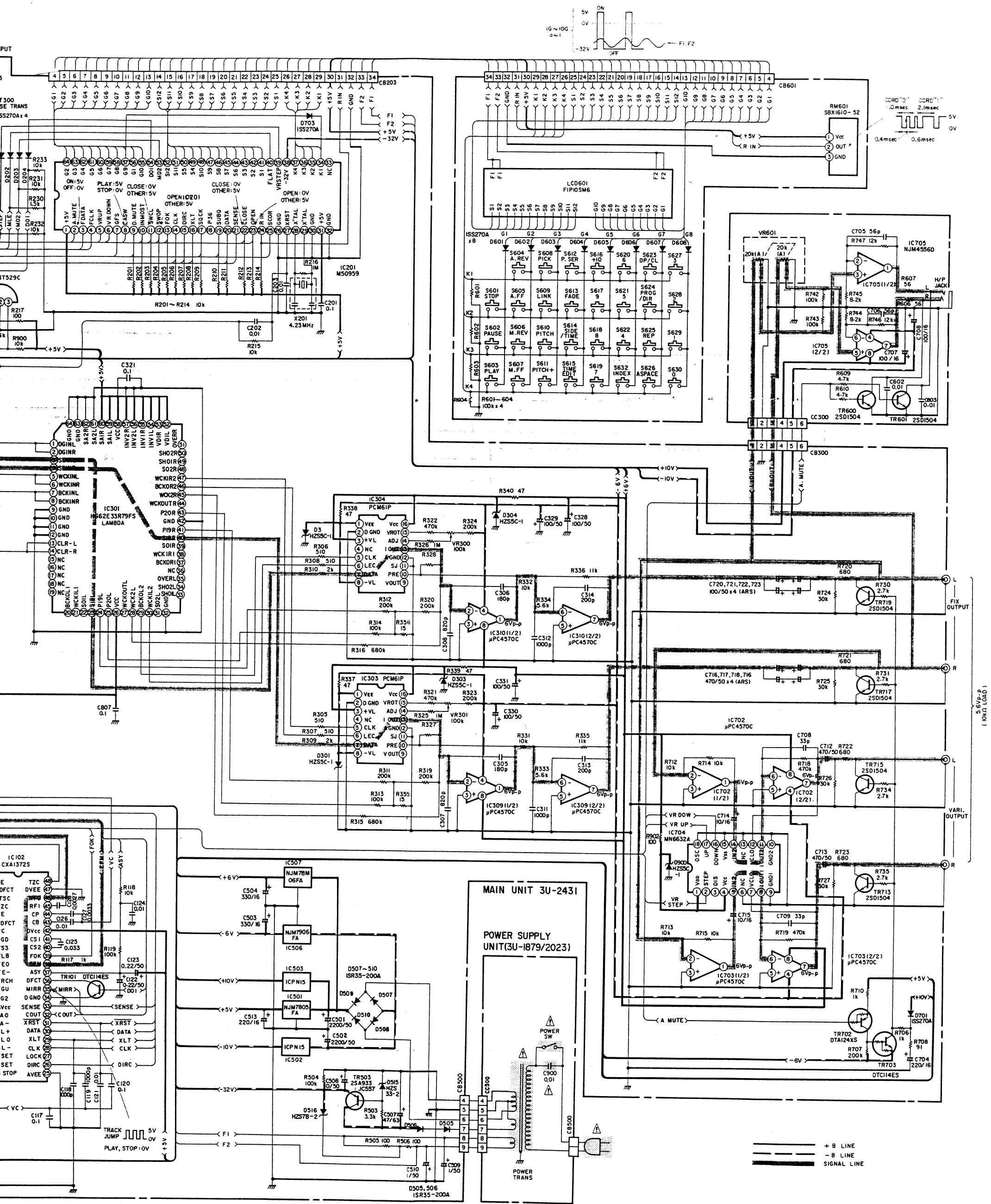

VALUES IN OHM. K=1,000 OHM, M=1,000,000 OHM
 VALUES IN MICRO FARAD. P=MICRO-MICRO FARAD
 CURRENT ARE MEASURED AT NO SIGNAL INPUT CONDITION.
 VALUES ARE SUBJECT TO CHANGE WITHOUT PRIOR NOTICE.