



ROTEL®

RCD-12

Stereo Compact Disc Player

Lecteur de disque compac

Stereo-CD-Player

Lettole CD

Reproductor de Discos Compactos

CD-Speler

CD-spelare

CD-проигрыватель

Owner's Manual

Manuel d'utilisation

Bedienungsanleitung

Manual de Instrucciones

Manuale di istruzioni

Gebruiksaanwijzing

Instruktionsbok

Register your product at
www.Rotel.com/register



CAUTION

RISK OF ELECTRIC SHOCK

DO NOT OPEN



CAUTION: TO REDUCE THE RISK OF ELECTRIC SHOCK, DO NOT REMOVE COVER. NO USER-SERVICEABLE PARTS INSIDE. REFER SERVICING TO QUALIFIED SERVICE PERSONNEL.



This symbol is to alert the user to the presence of uninsulated dangerous voltages inside the product's enclosure that may constitute a risk of electric shock.



This symbol is to alert the user to important operating and maintenance (service) instructions in this manual and literature accompanying the product.

APPLICABLE FOR USA, CANADA OR WHERE APPROVED FOR THE USAGE

CAUTION: TO PREVENT ELECTRIC SHOCK, MATCH WIDE BLADE OF PLUG TO WIDE SLOT. INSERT FULLY.

ATTENTION: POUR EVITER LES CHOCS ELECTRIQUES, INTRODUIRE LA LAME LA PLUS LARGE DE LA FICHE DANS LA BORNE CORRESPONDANTE DE LA PRISE ET POUSSER JUSQU'AU FOND.

This Class B digital apparatus complies with Canadian ICES-003.

Cet appareil numérique de la classe B est conforme à la norme NMB-003 du Canada.



Rotel products are designed to comply with international directives on the Restriction of Hazardous Substances (RoHS) in electrical and electronic equipment and the disposal of Waste Electrical and Electronic Equipment (WEEE). The crossed wheeled bin symbol indicates compliance and that the products must be appropriately recycled or processed in accordance with these directives.



This symbol means that this unit is double insulated. An earth connection is not required.

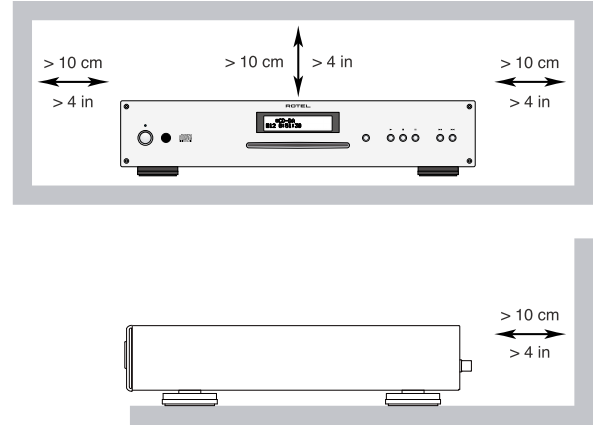

IMPORTANT FOR LASER PRODUCT

1. CLASS 1 LASER PRODUCT
 2. **DANGER:** Visible laser radiation when open and interlock failed or bypassed. Avoid direct exposure to beam.
 3. **CAUTION:** Do not open the top cover. There are no user serviceable parts inside the player; leave all servicing to qualified service personnel.
- WARNING!**
To reduce the risk of electrical shock, fires, etc.:
1. Do not remove screws, covers or cabinet.
 2. Do not expose the unit to rain or moisture.
 3. Do not touch the power cord or plug with wet hands.



Place the unit on a fixed, level surface strong enough to support its weight. Do not place it on a moveable cart that could tip over.

Notice

The rear mini USB connection should be handled by authorized persons only.

FCC Information

This equipment has been tested and found to comply with the limits for a Class B digital device, pursuant to Part 15 of the FCC Rules. These limits are designed to provide reasonable protection against harmful interference in a residential installation. This equipment generates, uses and can radiate radio frequency energy and, if not installed and used in accordance with the instruction, may cause harmful interference to radio communications.

However, there is no guarantee that interference will not occur in a particular installation. If this equipment does cause harmful interference to radio or television reception, which can be determined by turning the equipment off and on, the user is encouraged to try to correct the interference by one or more of the following measures:

- Reorient or relocate the receiving antenna.(TV, radio, etc.)
- Increase the separation between the equipment and receiver
- Connect the equipment to an outlet on circuit different from that to which the receiver is connected.
- Consult the dealer or an experienced radio/TV technician for additional help.

Caution

This device complies with part 15 of the FCC Rules. Operation is subject to the following to conditions: (1) This device may not cause harmful interference, and (2) this device must accept any interference received, including interference that may cause undesired operation.

NOTE TO CATV SYSTEM INSTALLER: Call the CATV system or antenna installer's attention to Article 820-40 of the NEC. This provides guidelines for proper grounding and, in particular, specifies that the cable ground shall be connected to the grounding system of the building, as close to the point of cable entry as practical. See installation diagram.

NOTE: This equipment has been tested and found to comply with the limits for a Class B digital device, pursuant to Part 15 of the FCC Rules. These limits are designed to provide reasonable protection against interference in a residential installation. This equipment generates and can radiate radio frequency energy and, if not installed and used in accordance with the instructions, may cause interference to radio or TV communications. There is no guarantee that interference will not occur in a particular installation. If this equipment does cause interference to radio or television reception, which can be determined by turning the equipment off and on, try to correct the interference by one or more of the following measures:

- Reorient or relocate the receiving antenna.
- Increase the separation between the unit and the television tuner.
- Connect the unit to an AC power outlet on a different electrical circuit.
- Consult your authorized Rotel retailer for assistance.

Important Safety Instructions

WARNING: There are no user serviceable parts inside. Refer all servicing to qualified service personnel.

WARNING: To reduce the risk of fire or electric shock, do not expose the unit to moisture or water. Do not expose the unit to dripping or splashing. Do not place objects filled with liquids, such as vases, on the unit. Do not allow foreign objects to get into the enclosure. If the unit is exposed to moisture, or a foreign object gets into the enclosure, immediately disconnect the power cord from the wall. Take the unit to a qualified service person for inspection and necessary repairs.

Read all the instructions before connecting or operating the component.

Keep this manual so you can refer to these safety instructions.

Heed all warnings and safety information in these instructions and on the product itself. Follow all operating instructions.

Clean the enclosure only with a dry cloth or a vacuum cleaner.

Do not use this unit near water.

You must allow a minimum 10 cm or 4 inches of unobstructed clearance around the unit.

Do not place the unit on a bed, sofa, rug, or similar surface that could block the ventilation openings. If the unit is placed in a bookcase or cabinet, there must be ventilation of the cabinet to allow proper cooling.

Keep the component away from radiators, heat registers, stoves, or any other appliance that produces heat.

The unit must be connected to a power supply only of the type and voltage specified on the rear panel. (USA: 120 V/60Hz, EC: 230V/50Hz)

Connect the component to the power outlet only with the supplied power supply cable or an exact equivalent. Do not modify the supplied cable. A polarized plug has two blades, with one wider than the other. A grounding plug has two blades plus a third grounding prong. These are provided for your safety. Do not defeat grounding and/or polarization safety provisions. If the supplied plug does not fit your outlet, please consult an electrician for replacement of the obsolete outlet. Do not use extension cords.

The main plug of the power cordset is a disconnect device of the apparatus. In order to completely disconnect the apparatus from the supply mains, the main plug of the power cordset should be unplugged from the mains (AC) outlet. The stand-by LED indicator will not be lit up to show the power cord is unplugged. The disconnect device shall remain readily operable.

Do not route the power cord where it will be crushed, pinched, bent, exposed to heat, or damaged in any way. Pay particular attention to the power cord at the plug and where the cord exits the back of the unit.

The power cord should be unplugged from the wall outlet during a lightning storm or if the unit is to be left unused for a long period of time.

Use only accessories specified by the manufacturer.

Use only with a cart, stand, rack, bracket or shelf system recommended by Rotel. Use caution when moving the unit in a stand or rack to avoid injury from a tip-over.

Immediately stop using the component and have it inspected and/or serviced by a qualified service agency if:

- The power supply cord or plug has been damaged
- Objects have fallen or liquid has been spilled into the unit
- The unit has been exposed to rain
- The unit shows signs of improper operation
- The unit has been dropped or damaged in any way

The batteries in the remote control shall not be exposed to excessive heat such as sunshine, fire or the like.

Figure 1: Controls and Connections
 Commandes et branchements
 Bedienelemente und Anschlüsse

Figure 1: Controles y Conexiones
 De bedieningsorganen en de aansluitingen
 Controlli e collegamenti
 Kontrollar och anslutningar

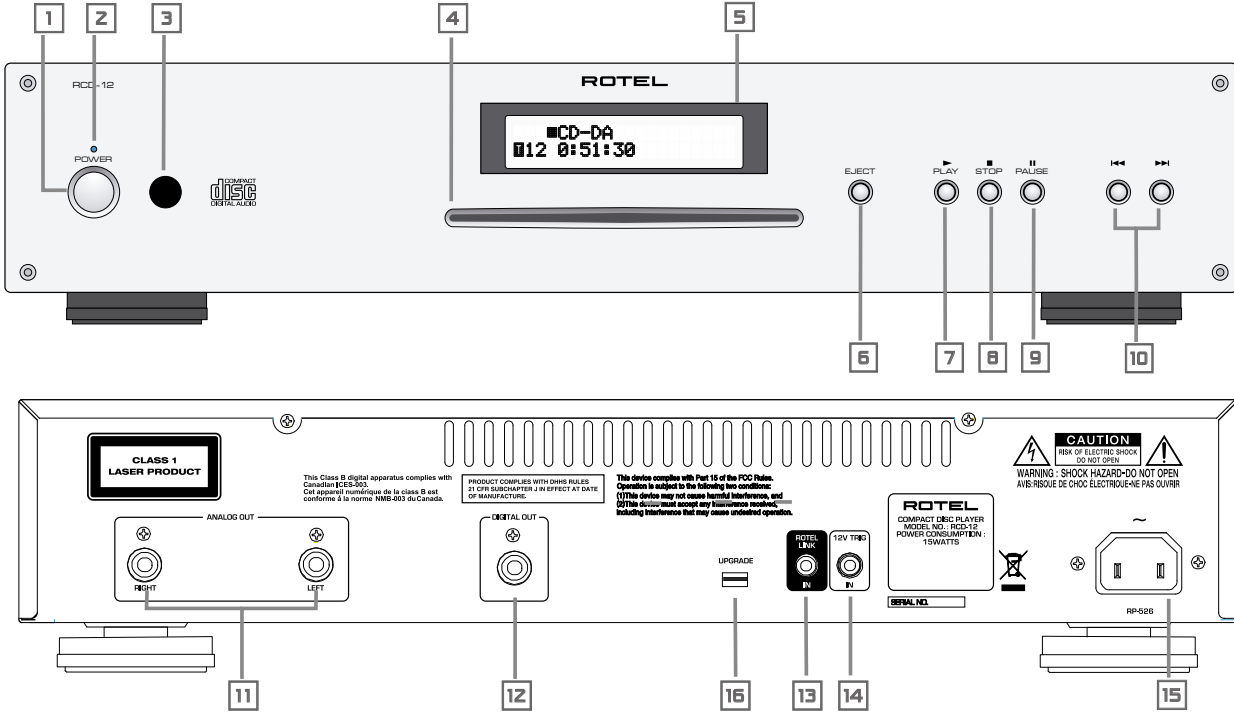

Figure 2: RR-D98 Remote Control
 Télécommande RR-D98
 Fernbedienung RR-D98
 Telecomando RR-D98
 Mando a Distancia RR-D98
 De RR-D98 afstandsbediening
 Fjärrkontroll RR-D98
 RR-D98

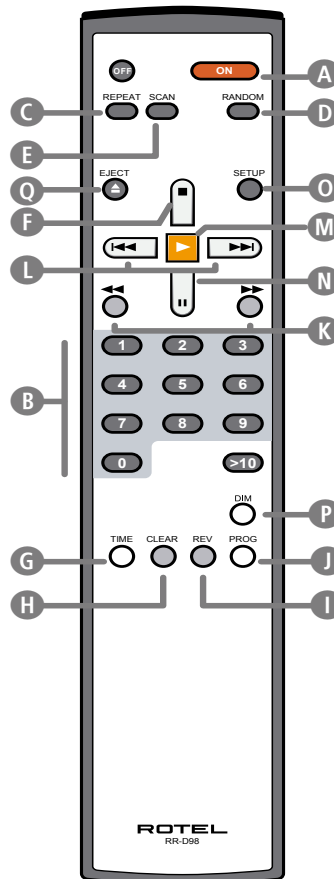
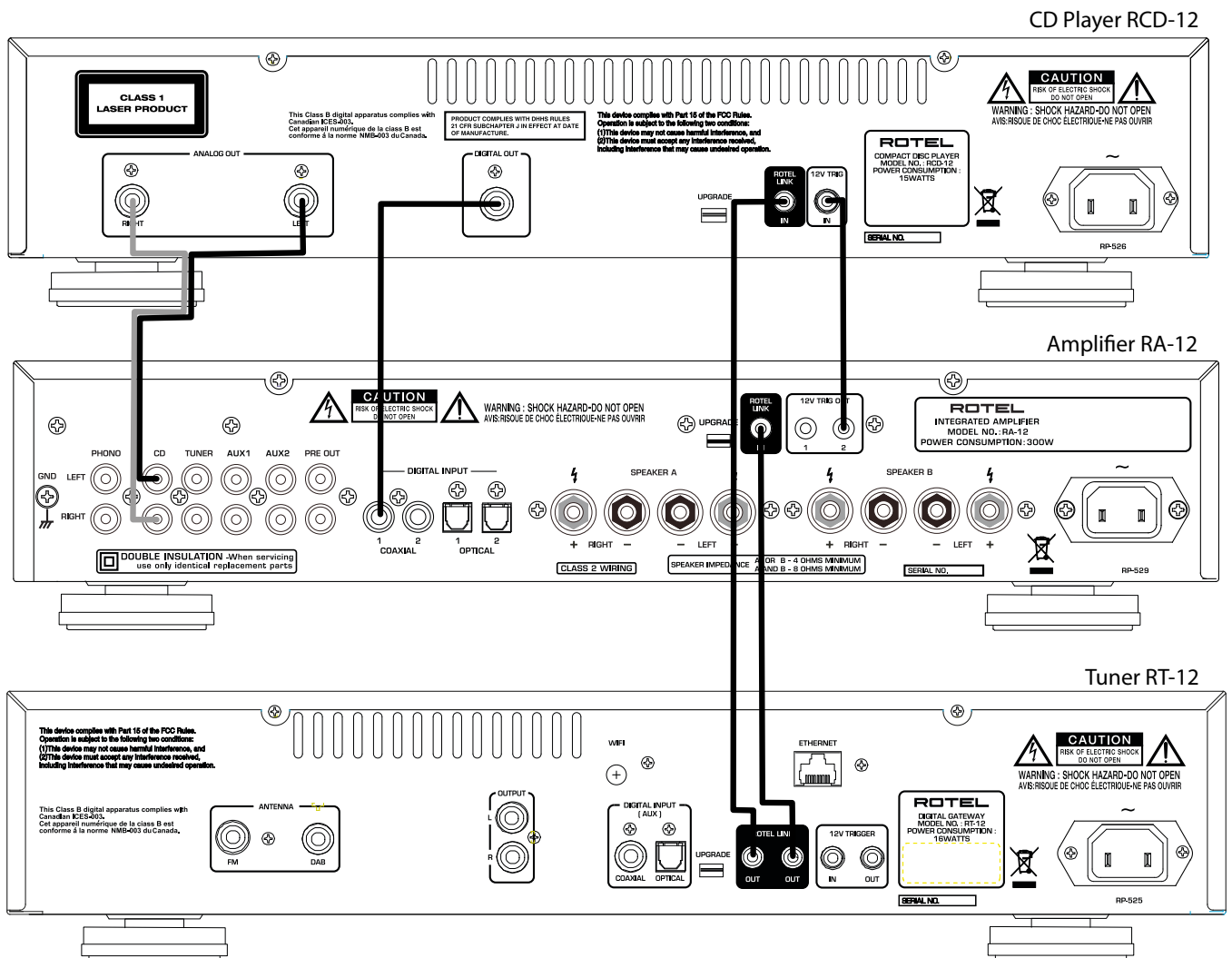

























Figure 3: Connections



Contents

Important Safety Instructions	3
Figure 1: Controls and Connections	4
Figure 2: RR-D98 Remote Control	4
Figure 3: Connections	5
About Rotel	6
About the RCD-12	6
Getting Started	7
A Few Precautions	7
Placement	7
Control Identification	7
AC Power and Control	7
AC Power Input 	7
Power Switch   and POWER Indicator 	7
Output Connections	7
Analog Outputs 	7
Digital Output 	7
OPERATION	8
Infrared Remote Control 	8
Display 	8
Disc Loader Slot 	8
EJECT Button  	8
PLAY Button  	8
STOP Button  	8
PAUSE Button  	8
TRACK Buttons  	8
DIRECT ACCESS Buttons 	8
SEARCH Button 	8
Additional Features	9
Rotel-Link 	10
12V Trigger Connection 	10
Remote Control Advanced Buttons	10
Troubleshooting	10
Power Indicator Is Not Lit	10
Fuse Replacement	10
NO SOUND	10
Specifications	11

About Rotel

Our story began over 50 years ago. Over the decades, we have received hundreds of awards for our products and satisfied hundreds of thousands of people who take their entertainment seriously – like you!

Rotel was founded by a family whose passionate interest in music led them to manufacture high-fidelity components of uncompromising quality. Through the years, that passion has remained undiminished and the family goal of providing exceptional value for audiophiles and music lovers, regardless of their budget, is shared by all Rotel employees.

Rotel's engineers work as a close team, listening to, and fine tuning, each new product until it reaches their exacting musical standards. They are free to choose components from around the world in order to make that product the best they can. You are likely to find capacitors from the United Kingdom and Germany, semiconductors from Japan or the United States, while toroidal power transformers are manufactured in Rotel's own factory.

We all have concerns about our environment. And, as more and more electronics are produced and later discarded, it is especially important for a manufacturer to do all it can to engineer products that have a minimum negative impact on landfill sites and water tables.

At Rotel, we are proud to do our part. We have reduced the lead content in our electronics by using special ROHS solder, while our new Class D (not digital) amplifiers are up to five times more efficient than our legacy designs and still deliver power and performance. These products run cool, give minimum wasted energy, are good for the environment and give better sound too.

Finally, we have printed this brochure on recycled paper stock.

While we understand that these are small first steps, they are still important ones. And we continue to pursue new methods and materials for a cleaner and greener manufacturing process.

All of us at Rotel thank you for buying this product. We are sure it will bring you many years of enjoyment.

About the RCD-12

Simply stated, the RCD-12 is designed to do one thing—deliver the most detailed, nuanced sound from every disc. Whether it is a conventional CD, or an MP3 or WMA encoded disc, the RCD-12 will faithfully reproduce all that is recorded on the disc. While the RCD-12 was under development. The design team went far beyond the usual measurable technical performance characteristics. Listening panels spent hundreds of hours fine tuning the audio performance, choosing the components that produced the best sound, that would “release the emotion in the music”. Whatever the artist and recording engineers put on the disc, the RCD-12 will deliver.

That said, the RCD-12 does feature some impressive hardware. The digital-to-analogue converter is a state of the art DAC from the world renowned British manufacturer, Wolfson. This very high performance stereo DAC is specifically designed for audio applications such as CD, DVD, and home theatre systems. All this, combined with Rotel's Balanced Design, ensures the RCD-12 will deliver the highest level of audio performance.

When used in a high-quality audio system, your Rotel CD player will provide years of enjoyment.

Getting Started

A Few Precautions

Please read this manual carefully. In addition to installation and operating instructions, it provides valuable information on various RCD-12 system configurations as well as general information that will help you get optimum performance from your system. Please contact your authorized Rotel dealer for answers to any questions you might have. In addition, all of us at Rotel welcome your questions and comments.

Save the RCD-12 shipping carton and all enclosed packing material for future use. Shipping or moving the RCD-12 in anything other than the original packing material may result in severe damage that is not covered by the warranty.

Fill out and send in the owner's registration card packed with the RCD-12. Also be sure to keep the original sales receipt. It is your best record of the date of purchase, which you will need in the event warranty service is required.

Placement

Use common sense when placing the RCD-12 in a cabinet or when stacking other equipment. Make sure that the shelf or cabinet can support its weight. Do not stack heavy components on top of the RCD-12. Avoid placing the unit where it may be subject to excessive heat such as on top of a large power amplifier or near a heat register. For best performance, avoid placing the unit where it may be subject to vibration, such as near a speaker.

Control Identification

This manual shows illustrations of the front and rear panels and the RR-D98 remote control. Each item in the illustrations is identified with a call out in a gray box. Through out this manual the items referred to in the text are identified by the corresponding call out. The items on the front and rear panels are identified with a number call out, such as 1. The items on the remote control are labeled with a letter call out, such as A.

AC Power and Control

AC Power Input 15

Your RCD-12 is configured at the factory for the proper AC voltage in the country where you purchased it (either 120 volts or 230 volts). The AC line configuration is noted on a decal on the back panel.

Note: *Should you move your CD player to another country, it may be possible to reconfigure it for use on a different line voltage. Do not attempt to perform this conversion yourself. Opening the enclosure of the RCD-12 exposes you to dangerous voltages. Consult a qualified service person or the Rotel factory service department for information.*

Note: *Some products are intended for sale in more than one country and as such are supplied with more than one AC cord. Please use only the cord appropriate for your country/region.*

The RCD-12 should be plugged directly into a 2-pin polarized wall outlet or into the switched outlet on another component in your audio system. Do not use an extension cord.

Be sure the power switch on the front panel of the RCD-12 is turned off (in the "out" position). Then, connect the supplied power cord to the AC power receptacle on the rear of the unit and the AC power outlet.

If you are going to be away from home for an extended period of time such as a month-long vacation, it is a sensible precaution to unplug your CD player (as well as other audio and video components) while you are away.

Power Switch 1 A and POWER Indicator 2

The power switch is located on the front panel of your CD player. To turn the CD player on, push the switch in. The LED indicator above the switch and the Display will light up, indicating that the CD player is turned on. To turn the CD player off, push the button again and return it to the "out" position.

Note: *If you are using a switched outlet to turn on and off your CD player, you should leave the power switch in the "ON" position. When AC power is applied to the unit, it will power up in fully active mode.*

Note: *When the power switch is in the "ON" position, the remote control ON and OFF buttons may be used to activate the CD player or put it in Standby mode. In Standby mode the power LED remains lit, but the display is turned off.*

Output Connections

The RCD-12 gives you a choice of two different kinds of output connections—an analog output signal from the built-in D/A converter for use with conventional analog audio components and a coax digital output which provides an unprocessed digital data signal for use with outboard D/A converters or digital processors.

Note: *To prevent loud noises that neither you nor your speakers will appreciate, make sure the CD player is turned off when you make any signal connections.*

Analog Outputs 11

[See Figure 3 for wiring illustration]

A pair of standard RCA jacks supplies an analog output signal from the RCD-12 to the source inputs of an audio preamplifier, integrated amplifier, or receiver.

Select high quality audio interconnect cables. Connect the left channel output of the RCD-12 to the left channel source input on the preamplifier or other component. Connect the right output of the RCD-12 to the right channel source input on the preamplifier or other component.

Digital Output 12

[See Figure 3 for wiring illustration]

If you are using an outboard D/A converter or other digital processor, you will need an unprocessed digital data stream from the RCD-12, taken before the built-in D/A converter. This signal is supplied by The RCD-12's back panel digital output jack. Using a standard 75 ohm coax digital cable, connect the RCD-12's coax digital output to the coax digital input connector on the outboard D/A converter.

Note: When playing CD-DA, MP3 and WMA discs, the Digital Output provides a PCM data stream. When a DTS CD is played a DTS data stream is provided.

OPERATION

The RCD-12 can be operated using its front panel buttons or from corresponding buttons on the supplied infrared remote control. Specific instructions for each of these controls are detailed below. Most of the buttons are duplicated on the front panel and on the IR remote control. However, there are a few exceptions where the buttons are only available on one or the other. These exceptions are noted in the instructions.

Infrared Remote Control

Before using the IR remote control, it is necessary to install two "UM-4/AAA" batteries (supplied). Remove the plastic cover on the back of the IR remote, install the batteries (observing the + and - polarity indications), and reinstall the cover.

To use the IR remote control, aim it at the IR sensor  located on the front panel of the RCD-12.

Display

A lighted Display on the front panel of the RCD-12 provides useful information about the status of the unit, activation of special features, and track/time information for the disc being played. Each of these indicators is described in the detailed operating instructions that follow.



Disc Loader Slot

A motor-driven slot loader, located in the center of the RCD-12, accept a compact disc. Place the compact disc into the slot, label-side up. Make sure the disc is properly centered before loading. The disc can be ejected by pressing the eject button as explained below.

Transport Control Buttons

These buttons provide basic control functions for the disc transport mechanism. Except where noted, all functions are available on the RCD-12 front panel and the IR remote control.

EJECT Button

When a disc is inserted into the front panel Disc Slot it is pulled into the disc transport. To eject the disc press the EJECT button on the front panel or the remote control. If you accidentally press either of these buttons, press the button again to re-load the disc.

When the eject button is pressed, the Display will read "EJECT". Once the disc is completely ejected, the display will read "NO DISC". When a disc is loaded, the Display will indicate the number of tracks on the disc and the total time of the disc in minutes and seconds.

PLAY Button

After the disc is loaded, press the PLAY button to start playing the disc. The number of the track being played and the elapsed time will be shown in the display, along with the PLAY indicator. Normally, the disc will start playing with the first track. However, you can select a different track using the TRACK buttons or the DIRECT ACCESS buttons (see below) before pressing the PLAY button to start playing a different selection.

STOP Button

Press the STOP button once to stop disc play. Press the PLAY button to resume disc play where it was stopped. If the STOP button is pressed twice, disc play stops, the display shows STOP and programmed selections are deleted (see below). When the PLAY button is pressed after pressing the STOP button twice, the disc begins playing from the first track.

PAUSE Button

This button is used to temporarily suspend play. The disc continues to spin and play will be resumed from the current position. The PAUSE indicator will light in the Display. To resume playing the disc, press the PAUSE button again or press the PLAY button.

TRACK Buttons

These buttons are used to select tracks on the disc. When a disc is playing, pressing the right TRACK button advances to the beginning of the next track. Pressing the left TRACK button returns to the beginning of the current track. Pressing twice quickly in succession returns to the beginning of the previous track. The new track number appears in the Display.

These buttons are also used to select a track before pressing the PLAY button or when memorizing tracks for the PROGRAM play mode (see below). These selections are made by continuously pressing the TRACK buttons until the desired track is reached.

In PROGRAM mode, the TRACK buttons advance or reverse to the next track in the memorized selection list.

DIRECT ACCESS Buttons

Remote Only

These eleven numeric buttons (labelled 1 through 0 and >10) are used to directly access a track from the IR remote control instead of stepping through the tracks using the TRACK buttons.

The first ten tracks on a disc can be selected by pressing the corresponding button. For example, to play the third track, press the 3 button on the remote control.

When accessing track numbers greater than 10, press the >10 button followed by the track number. For example, to select track 12, press the >10 button followed by the 1 button and then the 2 button.

The number of the selected track will appear in the main numeric area at the center of the Display.

The DIRECT ACCESS buttons may also be used to memorize tracks in PROGRAM mode (see below).

SEARCH Button

Remote Only

These buttons fast forward or fast reverse through the currently playing disc. One press of these buttons will fast forward or fast reverse at 2X normal speed. Press these buttons repeatedly will fast forward or fast

reverse at 4X, then 8X, 16X, and 32X normal speed. One more press of these buttons, or by pressing PLAY button returns the player to normal speed. While the buttons are pressed, you will hear high-speed audio.

Additional Features

These convenience features add extra functionality to the RCD-12, including the ability to memorize a group of tracks to be played, to repeat a disc, program, or track over and over, to play the tracks on a disc in random order, to automatically play the first 10 seconds of each track, and to select from several available time displays.

PROGRAM Button

Remote Only

This button, labeled PROG, allows you to memorize as many as 20 tracks on the current disc for playback in a specific order. For example, you could instruct the RCD-12 to play track 5, followed by track 3, followed by track 8.

Note: *Programmed play lists cannot be set up with MP3 and WMA discs.*

To begin a program:

1. Insert a disc into the slot loader. The RCD-12 will read the contents of the disc.
2. Press the PROG button on the remote control. The PROGRAM indicator will light up in the Display, along with "P-00" indicating that the unit is waiting for the first track to be memorized.
3. Enter the first track number using the DIRECT ACCESS buttons. Your selection will be memorized automatically and the Display indicator will change to "P-01", indicating that one track has been memorized. Continue entering the rest of your selections using the DIRECT ACCESS buttons. Note that there is no need to press the PROG button as each selection is memorized as it is entered.

Once you have memorized a play list, the RCD-12 remains in PROGRAM mode until you eject the disc or press the STOP button twice in succession. If you press the PLAY button, the memorized program will play instead of the entire disc, starting with the first selection in the memorized list.

When a PROGRAM has been memorized, most functions that would normally affect the entire disc operate on just the memorized program. For example, the TRACK buttons advance to the next track in the memorized program, not the next track on the disc. Likewise, the REPEAT button (see below) continuously plays the memorized program, not the entire disc.

Note: *The Random Play feature can not be used when using the Programmed Play feature.*

REVIEW Button

Remote Only

This button is used to review the memorized tracks in PROGRAM mode. Press the button and the first memorized track number will appear in order in the Display, for approximately five seconds. Pressing the REV button again while the track number is displayed will continue the review

sequence, showing the next memorized track. Continue pressing the REVIEW button to see the complete memorized track list.

If you do not press the REVIEW button while the track number is displayed, the review process is terminated and the unit resumes whatever mode it was in before you started to review.

Note that you may remove a selection from the play list during the review procedure using the CLEAR button, as described below.

CLEAR Button

Remote Only

This button allows you to remove a track selection from the memorized program play list during the review procedure described above. Follow the review procedure until the desired track number is displayed. Then, instead of pressing the REVIEW button to continue, remove the displayed track by pressing the CLEAR button while the number is still showing. You may then continue the review procedure.



RANDOM Button

Remote Only

This instructs the CD player to play tracks from the entire disc in random order. Once all of the selections have been played once, the disc will stop playing, unless the REPEAT Button (see below) has been engaged, in which case the random play will continue until the STOP button is pressed. When the RANDOM button is engaged, an  icon will be displayed.

REPEAT Button

Remote Only

This button allows you to repeat the current track or the entire disc continuously until the feature is cancelled by disengaging the REPEAT button or pressing STOP. The REPEAT button steps sequentially through the available options. Press the button once and the RCD-12 will repeat just the current track, displaying the  in the Display. Press the button a second time and the RCD-12 will repeat the entire disc, displaying  in the Display. Press the button a third time to cancel the REPEAT function.

As noted above, REPEAT can be used in conjunction with the RANDOM play feature.

Note: *The REPEAT function is automatically cancelled when the disc is ejected.*

SCAN Button

Remote Only

This feature automatically plays the first ten seconds of each track on the disc (or the memorized program). To activate the feature, press the SCAN button. The  icon appears in the Display. To stop scanning and resume normal operation at the current track, press the SCAN button again or press the PLAY button.

TIME Button

Remote Only

Normally, the RCD-12 displays the elapsed time of the currently playing track. The TIME button allows you to step through two alternative time displays. Pressing the button once displays the time remaining in the current track, which counts down as the track continues playing. Pressing

the button a second time displays the time remaining on the entire disc (or memorized program). Pressing the button a third time reverts to the standard elapsed time display. When the TIME feature is activated, the icon  appears in the Display in front of the time.

Note: When playing MP3 and WMA discs, only the regular elapsed time and the time remaining in the current track can be displayed.

Rotel-Link

This 3.5 mm stereo mini-jack (labeled ROTEL LINK IN) receives command codes from another Rotel-Link OUT enabled unit in the Rotel series of products. Allowing a set of products to operate as one using the ROTEL remote application. See Figure 3 for connections..

12V Trigger Connection

The RCD-12 can be activated by a 12 volt trigger signal from a Rotel preamplifier. The trigger input accepts any control signal (AC or DC) ranging from 3 volts to 30 volts. When a cable is connected to the input and a trigger signal is present, the CD Player is activated.

When the trigger signal is interrupted, the unit goes into standby mode. The front panel indicator light remains lit, but the display goes dark and the unit will not operate.

NOTE: When using the 12V Trigger feature, leave the POWER button in the ON position.

Remote Control Advanced Buttons

SETUP Button

Remote Only

By pressing the SETUP button, you can enter the following setup menu

1. DIMMER- changes the display brightness in 7 steps.
2. FACTORY DEFAULT - Resets to factory default. Select <YES> and press PLAY to confirm.
3. VERSION - Displays the current software version.
4. DISPLAY CONTRAST - Sets the contrast of the display.
5. EXIT - Exits this SETUP menu.

From the remote control, press the STOP/PAUSE/TRACK+/- keys to change the contents of the menu, press PLAY to enter the setting or confirm.

Note: You can also access the SETUP menu without the remote control. Press the STOP key on the front panel for 5 seconds. Press the TRACK buttons to change the contents of the menu and press STOP to enter the settings or confirm.

DIM Button

Remote Only

Press the DIM key sequentially to change the DISPLAY brightness. This the same as the DIMMER function under the SETUP menu.

UPGRADE USB mini socket

This socket is reserved for future software upgrades when necessary.

Troubleshooting

Most difficulties in audio systems are the result of incorrect connections, or improper control settings. If you encounter problems, isolate the area of the difficulty, check the control settings, determine the cause of the fault and make the necessary changes. If you are unable to get sound from the RCD-12, refer to the suggestions for the following conditions:

Power Indicator Is Not Lit

The Power Indicator and the basic items in the Display window should be lit whenever the RCD-12 is plugged into the wall power outlet and the Power button is pushed in. If it does not light, test the power outlet with another electrical device, such as a lamp. Be sure the power outlet being used is not controlled by a switch that has been turned off.

Fuse Replacement

If another electrical device works when plugged into the power outlet, but the Power Indicator and the Display still will not light when the RCD-12 is plugged into the wall outlet, it indicates that the internal power fuse may have blown. If you believe this has happened, contact your authorized Rotel dealer to get the fuse replaced.

NO SOUND

Check the cables between the RCD-12 and the amplifier inputs to be sure they are connected properly. Be sure the correct amplifier input is selected. Be sure the tape monitor system of the amplifier has not been activated. Check the wiring between the amplifier and the speakers.

Specifications

Total Harmonic Distortion + Noise	0.0045%@1kHz
Intermodulation Distortion	0.0045%@1kHz
Frequency Response ($\pm 0.5\text{db}$)	20-20,000 Hz
Channel Balance	$\pm 0.5\text{db}$
Phase Linearity	$\pm 0.5\text{degree}$
Channel Separation	> 98 dB @ 1kHz
Signal to Noise Ratio	> 100dB
Dynamic Range	> 96 dB
Digital to Analog Converters	Wolfson
Analog Output impedance	100 Ohms
Speed Accuracy, WOW & Flutter	Quartz Crystal Precision
Digital Output	0.5 Volt, Peak to Peak
Load Impedance	75 Ohms
Power Requirements (AC)	AC 120V, 60Hz (USA) AC 230V, 50 Hz (Europe)
Power Consumption	15 Watts
Standby Power Consumption	0.5 Watts
Dimensions (W, H, D)	17" x 3 ⁵ / ₈ " x 12 ⁵ / ₁₆ " 430 x 93 x 313 mm.
Panel Height	80 mm / 3 ¹ / ₈ "
Weight (net)	5.4 kgs, 11.9lbs.

All specifications are accurate at the time of printing. Rotel reserves the right to make improvements without notice.

Rotel and the Rotel HiFi logo are registered trademarks of The Rotel Co., Ltd. Tokyo, Japan.

The Rotel Co. Ltd.

Endo TN Building 2F.,
6-12-21, Meguro-Honcho,
Meguro, Tokyo 152-0002
Japan

Rotel of America

54 Concord Street
North Reading, MA 01864-2699
USA
Phone: +1 978-664-3820
Fax: +1 978-664-4109

Rotel Europe

Dale Road
Worthing, West Sussex BN11 2BH
England
Phone: + 44 (0)1903 221 761
Fax: +44 (0)1903 221 525

Rotel Deutschland

Vertrieb: B&W Group Germany GmbH
Kleine Heide 12
D-33790 Halle/Westf., Deutschland
Tel.: 05201 / 87170
Fax: 05201 / 73370
E-Mail: info@bwgroup.de
www.rotel-hifi.de

www.rotel.com

